



# Yaris Cross

## NAVIGATION SYSTEM OWNER'S



Toyota Motor Europe NV/SA Address: Avenue du bourget  
60 -1140 Brussels, Belgium

2015 TOYOTA MOTOR CORPORATION All rights reserved. This material may not be reproduced or copied, in whole or in part, without the written permission of Toyota Motor Corporation

|                                     |  |          |
|-------------------------------------|--|----------|
| <b>Quick guide</b>                  | <ul style="list-style-type: none"> <li>• Basic system overview</li> <li>• Giving guidance for the route quickly</li> </ul>   | <b>1</b> |
| <b>Basic function</b>               | <ul style="list-style-type: none"> <li>• Information to be read before operation</li> <li>• Setting initial settings before operation</li> <li>• Connecting the Bluetooth® device</li> </ul> | <b>2</b> |
| <b>Navigation system</b>            | <ul style="list-style-type: none"> <li>• Operating the map screen</li> <li>• Searching the map</li> <li>• Activating the route guidance</li> </ul>   | <b>3</b> |
| <b>Audio/visual system</b>          | <ul style="list-style-type: none"> <li>• Listening to the radio</li> <li>• Enjoying music and video</li> </ul>   | <b>4</b> |
| <b>Speech command system</b>        | <ul style="list-style-type: none"> <li>• Operating the speech command system</li> </ul>  | <b>5</b> |
| <b>Peripheral monitoring system</b> | <ul style="list-style-type: none"> <li>• Checking the situation behind the vehicle</li> </ul>  | <b>6</b> |
| <b>Phone</b>                        | <ul style="list-style-type: none"> <li>• Operating the phone<br/>(Hands-free system for cellular phones)</li> </ul>  | <b>7</b> |
| <b>Toyota online</b>                | <ul style="list-style-type: none"> <li>• Operating the Toyota online</li> </ul>  | <b>8</b> |
| <b>Index</b>                        | <ul style="list-style-type: none"> <li>• Search alphabetically</li> </ul>  |          |

## 2 TABLE OF CONTENTS

|  |    |  |     |
|--|----|--|-----|
| Introduction.....                                      | 6  | <b>2-4. Other settings</b>                           |     |
| Reading this manual.....                               | 8  | General settings.....                                | 57  |
| <b>1 Quick guide</b>                                   |    | Voice settings.....                                  | 60  |
| <b>1-1. Basic function</b>                             |    | Vehicle settings.....                                | 61  |
| Buttons overview .....                                 | 12 | <b>3 Navigation system</b>                           |     |
| “Menu” screen.....                                     | 15 | <b>3-1. Basic operation</b>                          |     |
| Status icon .....                                      | 16 | Navigation.....                                      | 64  |
| “Setup” screen .....                                   | 18 | Map screen operation .....                           | 69  |
| <b>1-2. Navigation operation</b>                       |    | Map screen information .....                         | 71  |
| Operating the map screen ....                          | 19 | Traffic messages.....                                | 75  |
| Guiding the route .....                                | 20 | <b>3-2. Destination search</b>                       |     |
| Registering home.....                                  | 21 | Search operation .....                               | 78  |
| <b>2 Basic function</b>                                |    | Starting route guidance.....                         | 87  |
| <b>2-1. Basic information before operation</b>         |    | <b>3-3. Route guidance</b>                           |     |
| Initial screen.....                                    | 24 | Route guidance.....                                  | 90  |
| Touch screen .....                                     | 25 | Editing route.....                                   | 93  |
| Home screen operation .....                            | 27 | <b>3-4. Favourite destinations</b>                   |     |
| Entering letters and numbers/list screen operation ... | 28 | Registering an entry.....                            | 98  |
| Screen adjustment.....                                 | 31 | Editing the entry information                        | 100 |
| Linking multi-information display and the system ..... | 33 | <b>3-5. Setup</b>                                    |     |
| <b>2-2. Connectivity settings</b>                      |    | Map settings .....                                   | 102 |
| Registering/Connecting a Bluetooth® device .....       | 34 | Traffic message settings .....                       | 105 |
| Setting Bluetooth® details.....                        | 38 | Route preferences settings.                          | 107 |
| Connecting to internet/Miracast® via Wi-Fi® .....      | 45 | <b>3-6. Tips for operating the navigation system</b> |     |
| <b>2-3. Apple CarPlay/Android Auto™</b>                |    | GPS (Global Positioning System) .....                | 109 |
| Apple CarPlay/Android Auto .                           | 50 | Navigation database updates .....                    | 111 |

|          |  |          |   |          |
|----------|--|----------|---|----------|
| <b>4</b> | <b>Audio/visual system</b>                                 | <b>6</b> | <b>Peripheral monitoring system</b>   | <b>1</b> |
|          | <b>4-1. Basic operation</b>                                |          | <b>6-1. Rear view monitor system</b>  | <b>2</b> |
|          | Quick reference ..... <b>114</b>                           |          | Rear view monitor system .. <b>154</b>  | <b>3</b> |
|          | Some basics ..... <b>115</b>                               |          | Rear view monitor system pre-<br>cautions ..... <b>156</b>                                    | <b>4</b> |
|          | <b>4-2. Radio operation</b>                                |          | Things you should know ..... <b>160</b>   | <b>5</b> |
|          | AM/FM/DAB radio ..... <b>120</b>                           |          | <b>6-2. Panoramic view monitor (vehi-<br/>cles with Toyota Teammate<br/>Advanced Park)</b>    | <b>6</b> |
|          | <b>4-3. Media operation</b>                                |          | Panoramic view monitor (vehi-<br>cles with Toyota Teammate<br>Advanced Park) ..... <b>162</b> | <b>7</b> |
|          | USB memory ..... <b>125</b>                                |          | When the shift position is in the<br>“P” ..... <b>165</b>                                     | <b>8</b> |
|          | iPod/iPhone (Apple CarPlay)<br>..... <b>127</b>            |          | When the shift position is in the<br>“D” or “N” ..... <b>167</b>                              |          |
|          | Android Auto ..... <b>130</b>                              |          | When the shift position is in the<br>“R” ..... <b>172</b>                                     |          |
|          | Bluetooth® audio ..... <b>131</b>                          |          | When folding the outside rear<br>view mirrors ..... <b>178</b>                                |          |
|          | Miracast® ..... <b>134</b>                                 |          | Magnifying function ..... <b>180</b>  |          |
|          | <b>4-4. Audio/visual remote controls</b>                   |          | Customizing the panoramic view<br>monitor ..... <b>181</b>                                    |          |
|          | Steering switches ..... <b>137</b>                         |          | Panoramic view monitor precau-<br>tions ..... <b>182</b>                                      |          |
|          | <b>4-5. Setup</b>  |          | Things you should know ..... <b>194</b>   |          |
|          | Audio settings ..... <b>138</b>                            |          |   |          |
|          | <b>4-6. Tips for operating the<br/>audio/visual system</b> |          |   |          |
|          | Operating information ..... <b>139</b>                     |          |   |          |
| <b>5</b> | <b>Speech command system</b>                               |          |   |          |
|          | <b>5-1. Speech command system<br/>operation</b>            |          |   |          |
|          | Speech command system .. <b>148</b>                        |          |   |          |
|          | Command list ..... <b>150</b>                              |          |   |          |

## 4 TABLE OF CONTENTS

---

### 7 Phone

- 7-1. Phone operation (Hands-free system for cellular phones)**
  - Quick reference .....**198**
  - Some basics .....**199**
  - Placing a call using the Bluetooth® hands-free system **203**
  - Receiving a call using the Bluetooth® hands-free system **207**
  - Talking on the Bluetooth® hands-free system .....**207**
  - Bluetooth® phone message function .....**209**
- 7-2. Setup**
  - Phone settings .....**214**
- 7-3. What to do if...**
  - Troubleshooting .....**223**

### 8 Toyota online

- 8-1. Toyota online**
  - Toyota online.....**228**
  - Settings required for using the service .....**231**
  - Toyota online applications operation.....**232**
  - Online search.....**233**
  - Importing favourites and stored routes.....**233**
  - Street View .....**235**
  - Weather .....**235**
  - Parking.....**236**
  - Fuel price .....**237**
- 8-2. Setup**
  - Online settings .....**239**

### Index

- Alphabetical Index .....**244**

1

2

3

4

5

6

7

8

## Introduction

### Navigation and multimedia system owner's manual

This manual explains the operation of the system. Please read this manual carefully to ensure proper use. Keep this manual in your vehicle at all times.

The screen shots in this document and the actual screens of the system differ depending on whether the functions and/or a contract existed and the map data available at the time of producing this document.

The screens in this manual will also differ if the screen theme settings have been changed. (Theme setting: →P.57)

In some situations when changing between screens, it may take longer than normal for the screen to change, the screen may be blank momentarily or noise may be displayed.

Please be aware that the content of this manual may be different from the system in some cases, such as when the system's software is updated.

The company names and product names appearing on this manual are trademarks and registered trademarks of their respective companies.

## Navigation system

The navigation system is one of the most technologically advanced vehicle accessories ever developed. The system receives satellite signals from the Global Positioning System (GPS) operated by the U.S. Department of Defense. Using these signals and other vehicle sensors, the system indicates your present position and assists in locating a desired destination.

The navigation system is designed to select efficient routes from your present starting location to your destination. The system is also designed to direct you to a destination that is unfamiliar to you in an efficient manner. The map database was made by Harman international, based on HERE maps. The calculated routes may not be the shortest nor the least traffic congested. Your own personal local knowledge or "short cut" may at times be faster than the calculated routes.

The navigation system's database includes Point of Interest categories to allow you to easily select destinations such as restaurants and hotels. If a destination is not in the database, you can enter the street address or a major intersection close to it and the system will guide you there.

The system will provide both a

visual map and audio instructions. The audio instructions will announce the distance remaining and the direction to turn when approaching an intersection. These voice instructions will help you keep your eyes on the road and are timed to provide enough time to allow you to maneuver, change lanes or slow down.



Please be aware that all current vehicle navigation systems have certain limitations that may affect their ability to perform properly. The accuracy of the vehicle's position depends on satellite conditions, road configuration, vehicle condition or other circumstances. For more information on the limitations of the system, refer to page 109.

**TOYOTA MOTOR CORPORATION**

**Reading this manual**

**Explains symbols used in this manual**

**Symbols in this manual**

| Symbols   | Meanings  |
|---|---|
|    | <b>WARNING:</b><br>Explains something that, if not obeyed, could cause death or serious injury to people.                         |
|   | <b>NOTICE:</b><br>Explains something that, if not obeyed, could cause damage to or a malfunction in the vehicle or its equipment. |
|  | Indicates operating or working procedures. Follow the steps in numerical order.   |

**Symbols in illustrations**

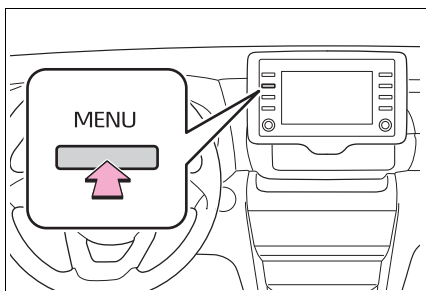

| Symbols   | Meanings  |
|---|---|
|  | Indicates the action (pushing, turning, etc.) used to operate switches and other devices. |

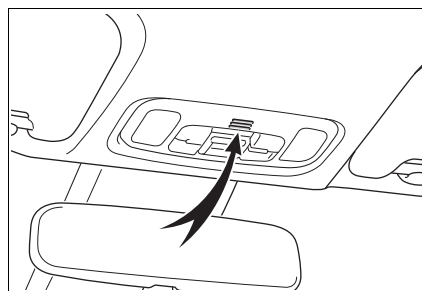

| Symbols   | Meanings   |
|---|--|
|  | Indicates the component or position being explained. |

**Different writing styles for gasoline and hybrid vehicles**

Information for hybrid vehicles is written in brackets next to the information for gasoline vehicles.

Example

Turn the engine switch<sup>\*1</sup> <power switch><sup>\*2</sup> to ON.

\*1: Vehicles with gasoline engine

\*2: Vehicles with hybrid system

**Safety instruction (models without navigation function)**

To use this system in the safest possible manner, follow all the safety tips shown below.

Do not use any feature of this system to the extent it becomes a distraction and prevents safe driving. The first priority while driving should always be the safe operation of the vehicle. While driving, be sure to observe all traffic regulations.

Prior to the actual use of this system, learn how to use it and become thoroughly familiar with it. Read the entire manual to make sure you understand the system. Do not allow other people to use this system until they have read and understood the instructions in this manual.

For your safety, some functions may become inoperable when driving. Unavailable screen buttons are dimmed.



#### WARNING

- Exercise extreme caution if operating the system while driving. Insufficient attention to the road, traffic or weather conditions may cause an accident.

#### Safety instruction (models with navigation function)

To use this system in the safest possible manner, follow all the safety tips shown below.

This system is intended to assist in reaching the destination and, if used properly, can do so. The driver is solely responsible for the safe operation of your vehicle and

the safety of your passengers.

Do not use any feature of this system to the extent it becomes a distraction and prevents safe driving. The first priority while driving should always be the safe operation of the vehicle. While driving, be sure to observe all traffic regulations.

Prior to the actual use of this system, learn how to use it and become thoroughly familiar with it. Read the entire manual to make sure you understand the system. Do not allow other people to use this system until they have read and understood the instructions in this manual.

For your safety, some functions may become inoperable when driving. Unavailable screen buttons are dimmed.



#### WARNING

- Exercise extreme caution if operating the system while driving. Insufficient attention to the road, traffic or weather conditions may cause an accident.
- While driving, be sure to obey the traffic regulations and maintain awareness of the road conditions. If a traffic sign on the road has been changed, route guidance may not have the updated information such as the direction of a one way street.

While driving, listen to the voice instructions as much as possible and glance at the screen briefly and only when it is safe. However, do

not totally rely on voice guidance. Use it just for reference. If the system cannot determine the current position correctly, there is a possibility of incorrect, late, or non-voice guidance.

The data in the system may occasionally be incomplete. Road conditions, including driving restrictions (no left turns, street closures, etc.) frequently change. Therefore, before following any instructions from the system, look to see whether the instruction can be done safely and legally.

This system cannot warn about such things as the safety of an area, condition of streets, and availability of emergency services. If unsure about the safety of an area, do not drive into it.

Under no circumstances is this system a substitute for the driver's personal judgement.

Use this system only in locations where it is legal to do so. Some areas may have laws prohibiting the use of video and navigation screens next to the driver.

**Quick guide**

**1**

**11**

**1**

Quick guide

**1-1. Basic function**

- Buttons overview ..... **12**
- “Menu” screen ..... **15**
- Status icon ..... **16**
- “Setup” screen ..... **18**

**1-2. Navigation operation**

- Operating the map screen .. **19**
- Guiding the route ..... **20**
- Registering home ..... **21**

Buttons overview

Operations of each part

- ▶ 7-inch display model

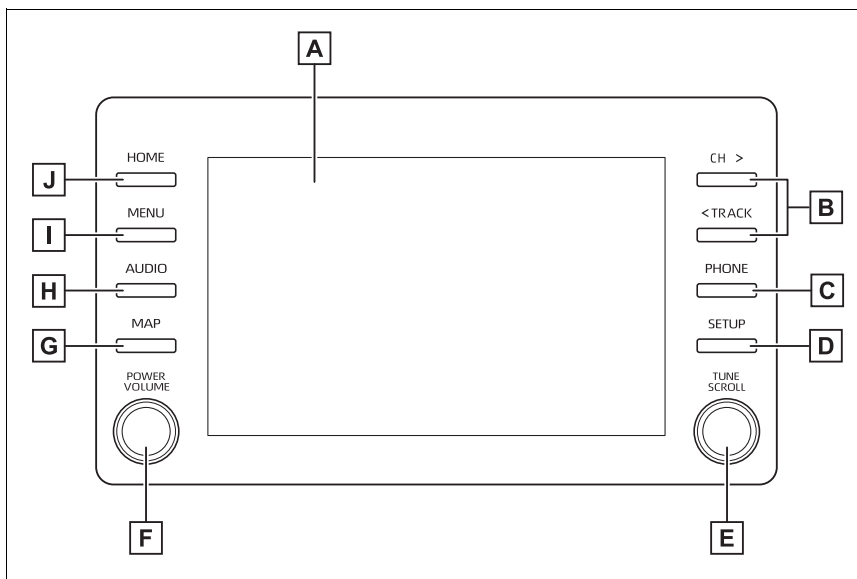

## ▶ 8-inch display model

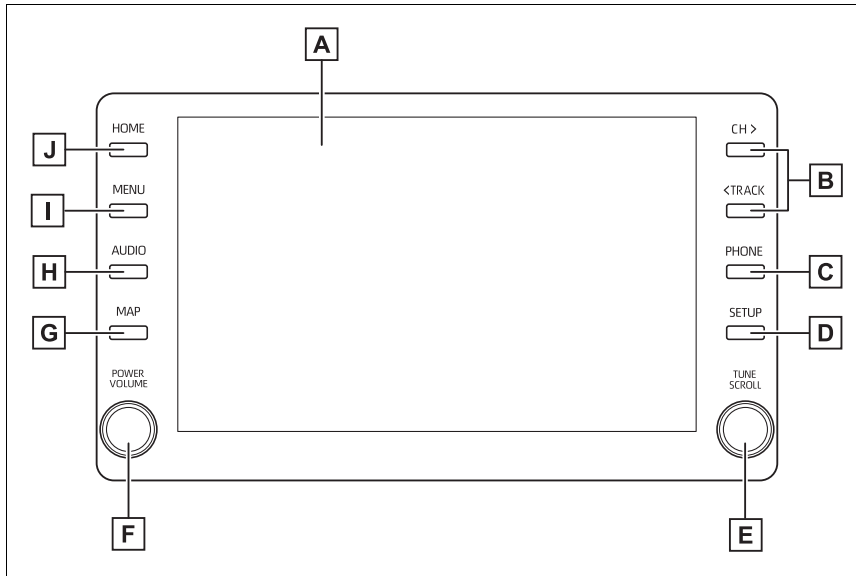

- A** By touching the screen with your finger, you can control the selected functions. (→P.25)
- B** Press to seek up or down for a radio station or to access a desired track/file. (→P.120, 125, 127, 131)
- C** Press to access the Bluetooth<sup>®</sup> hands-free system. (→P.198)
- When an Apple CarPlay connection is established, press to display the phone application screen.
- D** Press to display the “Setup” screen. (→P.18)
- E** Turn to change the radio station or skip to the next or previous track/file. (→P.120, 125, 127, 131)
- F** Press to turn the audio/visual system on and off, and turn it to adjust the volume. Press and hold to restart the system. (→P.24, 115)
- G** Press to display the map screen.<sup>\*1</sup> (→P.64)
- When an Apple CarPlay/Android Auto connection is established, press to display the Maps application screen.<sup>\*2</sup>
- H** Press to access the audio/visual system. (→P.114, 115)

## 14 1-1. Basic function

---

**I** Press to display the “Menu” screen. (→P.15)

**J** Press to display the home screen. (→P.27)

\*1: Models with navigation function only

\*2: Models without navigation function only

---

● This illustration is for left-hand drive vehicles. The button positions and shapes differ for right-hand drive vehicles.

**“Menu” screen**

1

**Menu screen operation**

Quick guide

Press the “MENU” button to display the “Menu” screen.

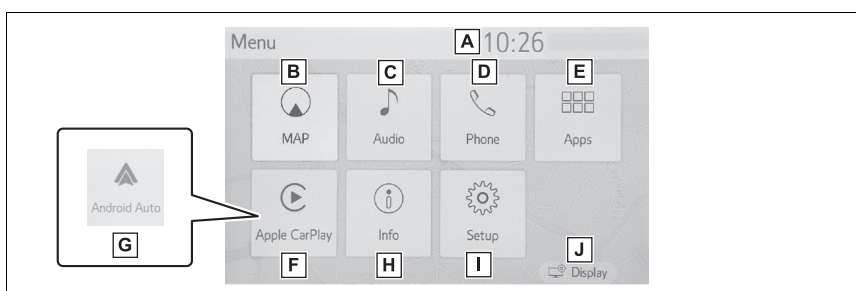

- A** Displays the clock. Select to display the clock settings screen. (→P.58)
- B** Select to display the map screen. \*1 (→P.64)
- C** Select to display the audio control screen. (→P.114)
- D** Select to display the hands-free operation screen. (→P.198)
  - When an Apple CarPlay connection is established, select to display the phone application screen.
- E** Select to display the application screen. \*1, 2, 3 (→P.228)
- F** When an Apple CarPlay connection is established, select to display the home screen of Apple CarPlay. \*3 (→P.50)
- G** When an Android Auto connection is established, select to display the home screen of Android Auto. \*3 (→P.51)
- H** Select to display the fuel consumption or energy monitor screen. \*4
- I** Select to display the “Setup” screen. (→P.18)
- J** Select to adjust the contrast and brightness of the screens, etc. (→P.31)

\*1: Models with navigation function only

\*2: When an Apple CarPlay/Android Auto connection is established, this function will be unavailable.

\*3: This function is not made available in some countries or areas.

\*4: Refer to the “Owner’s Manual”.

**Status icon**

Status icons are displayed at the top of the screen.

**Status icon explanation**

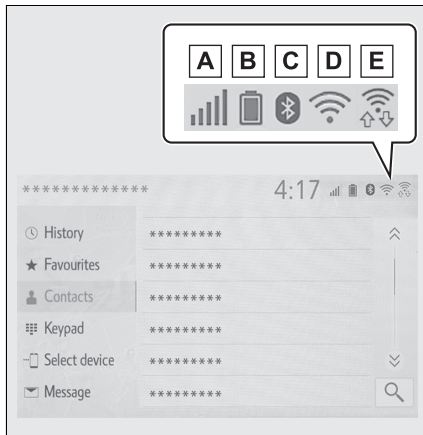

- A** The reception level of the connected phone display (→P.16)
- B** Remaining battery charge display (→P.17)
- C** Bluetooth® phone connection condition display (→P.17)
- D** Wi-Fi® connection condition display\* (→P.16)
- E** Shown during data communication performed via Miracast® (→P.16)

\*: Models with navigation function only

● The number of status icons that can be displayed differs depending on the displayed screen.

**Reception level display**

The level of reception does not always correspond with the level displayed on the cellular phone. The level of reception may not be displayed depending on the phone you have.

When the cellular phone is out of the service area or in a place inaccessible by radio waves, is displayed.

“Rm” is displayed when receiving in a roaming area. While roaming, display “Rm” top-left on the icon.

The receiving area may not be displayed depending on the type of Bluetooth® phone you have.



▶ While connected with cellular phone

| Level     | Indicators |
|-----------|------------|
| Poor      |            |
| Excellent |            |

▶ When using Wi-Fi®

| Level         | Indicators |
|---------------|------------|
| No connection |            |
| Poor          |            |
| Excellent     |            |

► When using Miracast®

| Level         | Indicators  |
|---------------|---|
| No connection |  |
| Poor          |  |
| Excellent     |  |



- When Wi-Fi®/Miracast® function is off, no item is displayed.

### Remaining battery charge display

The amount displayed does not always correspond with the amount displayed on the Bluetooth® device.

The amount of battery charge left may not be displayed depending on the type of the Bluetooth® device connected.

This system does not have a charging function.

| Remaining charge | Indicators  |
|------------------|---|
| Empty            |  |
| Full             |  |

### Bluetooth® connection condition display

An antenna for the Bluetooth® connection is built into the instrument panel.



The condition of the Bluetooth® connection may deteriorate and the

system may not function when a Bluetooth® phone is used in the following conditions and/or places:

The cellular phone is obstructed by certain objects (such as when it is behind the seat or in the glove box or console box).

The cellular phone is touching or is covered with metal materials.

Leave the Bluetooth® phone in a place where the condition of the Bluetooth® connection is good.

| Indicators  | Conditions   |
|---|--|
| <br>(Blue)  | Indicates that the condition of the Bluetooth® connection is good.         |
| <br>(Gray) | While in this condition, sound quality during phone calls may deteriorate. |
|            | Indicates that the cellular phone is not connected via Bluetooth®.         |

**“Setup” screen**

**“Setup” screen**

Press the “SETUP” button, or press the “MENU” button, then select “Setup” to display the “Setup” screen. The items shown on the “Setup” screen can be set.

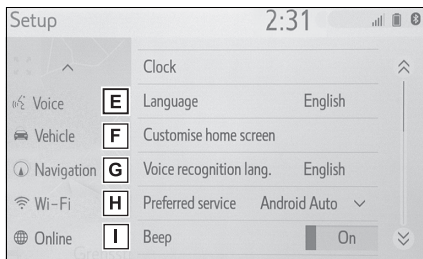
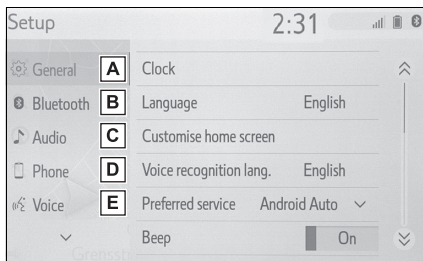

- A** Select to change the selected language, operation sound settings, etc. (→P.57)
- B** Select to set Bluetooth® device and Bluetooth® system settings.(→P.38)
- C** Select to set audio settings. (→P.138)
- D** Select to set the phone sound, contacts settings, etc. (→P.214)
- E** Select to set the voice settings.

(→P.60)

- F** Select to set vehicle information. (→P.61)

- G** Select to set map settings, traffic information, route preferences settings, etc. \*1 (→P.102, 105, 107)

- H** Select to set Wi-Fi® connection settings. (→P.45)

- I** Select to set Toyota online settings. \*1, 2 (→P.239)

\*1: Models with navigation function only

\*2: This function is not made available in some countries or areas.

## Operating the map screen\*

\*: Models with navigation function

### Displaying the current position of the vehicle on the map screen

- 1 Press the "MAP" button.

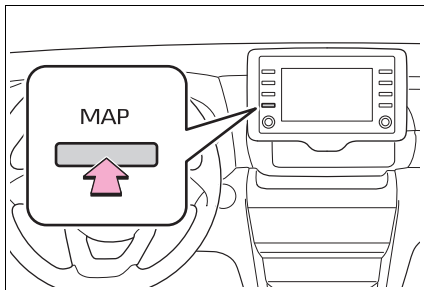

- 2 The current position of the vehicle is displayed on the map screen.

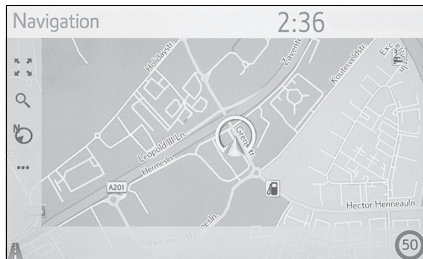

The following operations can also be performed.

- Changing the map direction →P.70
- Displaying 3D map →P.70

### Moving the map screen

- 1 Select the desired point on the map screen.

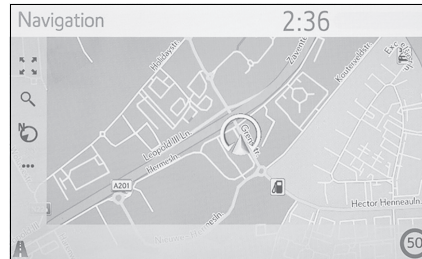

- Move the desired point on the centre of the map screen.
- It is possible to do the drag or flick operation on the screen.

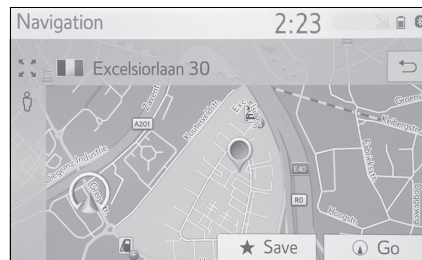

- Press the "MAP" button to return to the current position.
- For detailed operation about moving the map screen: →P.69

### Zooming in/out the map

#### ■ Zooming in the map

- 1 Select  on the map screen.
- 2 Select "+" or pinch out on the screen. (→P.69)

#### ■ Zooming out the map

- 1 Select  on the map screen.

## 20 1-2. Navigation operation

- 2 Select “-” or pinch in on the screen. (→P.69)

### Guiding the route\*

\*: Models with navigation function

### Setting the destination

- 1 Press the “MAP” button.

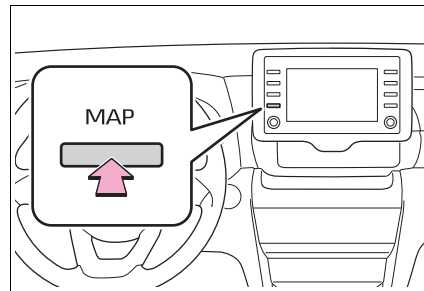

- 2 Select  on the map screen.
- 3 Search for a destination.

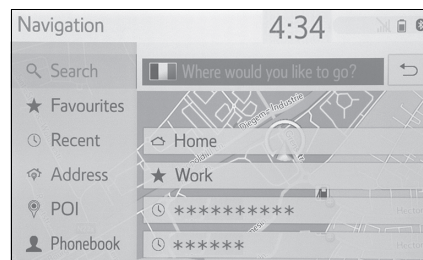



- There are different kinds of methods to search for a destination. (→P.78)
- 4 Select “Go”.
  - Check that the route overview is displayed. (→P.87)
  - 5 Select “Destination”.
  - Guidance to the destination is displayed on the screen and can be heard via voice guidance.

### Stopping route guidance

When route guidance is no longer necessary, such as when you know the rest of the route to your destination, the route guidance can be stopped.

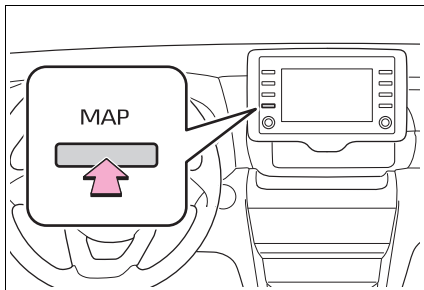
- 1 Press the "MAP" button.



- 2 Select  on the map screen.
- 3 Select "Stop guidance".

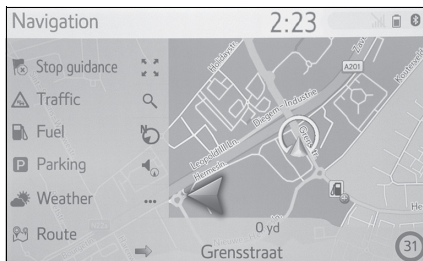



### Registering home\*

\*: Models with navigation function

### Registering home

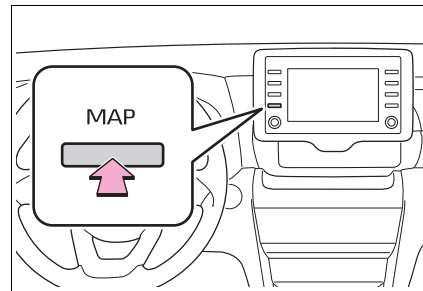
- 1 Press the "MAP" button.



- 2 Select  on the map screen.
- 3 Select "Favourites".
- 4 Select "Home".

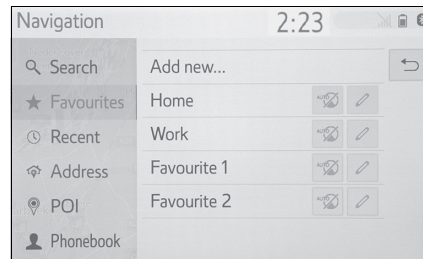

- 5 Select "Yes".
- 6 Search for your home.
  - There are different kinds of methods to search for your home. (→P.78)
- 7 Select "Enter".
  - Registration of home is complete.
  - Editing the name, address and route: →P.100

### Setting home as the destination

- 1 Press the "MAP" button.

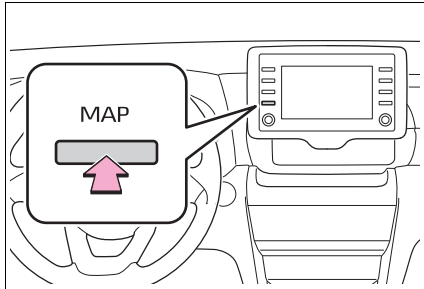

- 2 Select  on the map screen.
- 3 Select "Home".

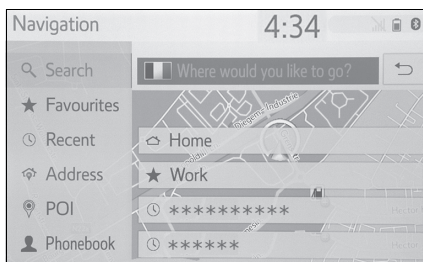

- Selecting routes other than the one recommended (→P.87)
- Guidance to the destination is displayed on the screen and can be heard via voice guidance.

**2-1. Basic information before operation**

- Initial screen ..... **24**
- Touch screen ..... **25**
- Home screen operation ..... **27**
- Entering letters and numbers/list screen operation . **28**
- Screen adjustment..... **31**
- Linking multi-information display and the system..... **33**

**2-2. Connectivity settings**

- Registering/Connecting a Bluetooth® device ..... **34**
- Setting Bluetooth® details... **38**
- Connecting to internet/Miracast® via Wi-Fi® ..... **45**

**2-3. Apple CarPlay/Android Auto™**

- Apple CarPlay/Android Auto **50**

**2-4. Other settings**

- General settings ..... **57**
- Voice settings ..... **60**
- Vehicle settings..... **61**

For vehicles sold outside Europe, some of the functions cannot be operated while driving.

### Initial screen

When the engine switch <power switch> is turned to ACC or ON, the initial screen will be displayed and the system will begin operating.

### Caution screen

After a few seconds, the caution screen will be displayed.

After about 5 seconds or selecting “Continue”, the caution screen automatically switches to the next screen.



#### WARNING

- When the vehicle is stopped with the engine running <the hybrid system operating>, always apply the parking brake for safety.

### Restarting the system

When system response is extremely slow, the system can be restarted.

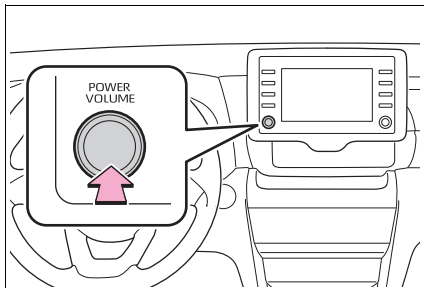

- 1 Press and hold the “POWER VOLUME” knob for 3 seconds or more.



## Touch screen

### Touch screen gestures

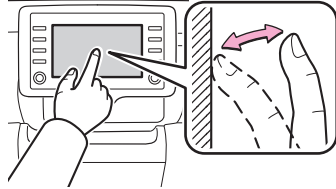
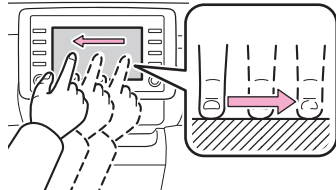
Operations are performed by touching the touch screen directly with your finger.

| Operation method  | Outline  | Main use   |
|---|--|--|
|    | <ul style="list-style-type: none"> <li>• Touch</li> </ul> <p>Quickly touch and release once.</p>   | <ul style="list-style-type: none"> <li>• Selecting an item on the screen</li> </ul>  |
|  | <ul style="list-style-type: none"> <li>• Drag<sup>*1</sup></li> </ul> <p>Touch the screen with your finger, and move the screen to the desired position.</p> | <ul style="list-style-type: none"> <li>• Scrolling the lists</li> <li>• Scrolling the map screen<sup>*2</sup></li> <li>• Moving an item on a list</li> </ul> |
|  | <ul style="list-style-type: none"> <li>• Flick<sup>*1</sup></li> </ul> <p>Quickly move the screen by flicking with your finger.</p>                          | <ul style="list-style-type: none"> <li>• Scrolling the main screen page</li> <li>• Scrolling the map screen<sup>*2</sup></li> </ul>                          |
|  | <ul style="list-style-type: none"> <li>• Pinch in/Pinch out<sup>*2, 3</sup></li> </ul> <p>Slide fingers toward each other or apart on the screen.</p>        | <ul style="list-style-type: none"> <li>• Changing the scale of the map<sup>*2</sup></li> </ul>   |

<sup>\*1</sup>: The above operations may not be performed on all screens.

<sup>\*2</sup>: Models with navigation function

\*3: The Apple CarPlay Maps application is not compatible with pinch multi-touch gestures.

- Flick operations may not be performed smoothly at high altitudes.

### Touch screen operation

**This system is operated mainly by the buttons on the screen. (Referred to as screen buttons in this manual.)**

**When a screen button is touched, a beep sounds. (To set the beep sound: →P.57)**





#### NOTICE

- To prevent damaging the screen, lightly touch the screen buttons with your finger.
- Do not use objects other than your finger to touch the screen.
- Wipe off fingerprints using a glass cleaning cloth. Do not use chemical cleaners to clean the screen, as they may damage the touch screen.
- Do not use the following liquids to clean the screen, as they may cause discoloration: Organic solutions, such as benzine, gasoline or alcohol, and alkaline solutions.

- If the system does not respond to touching a screen button, move your finger away from the screen and then touch it again.
- Dimmed screen buttons cannot be operated.
- The displayed image may become darker and moving images may be slightly distorted when the screen is cold.
- In extremely cold conditions, the screen may not be displayed and the

data input by a user may be deleted. Also, the screen buttons may be harder than usual to depress.

- When you look at the screen through polarized material such as polarized sunglasses, the screen may be dark and hard to see. If so, look at the screen from different angles, adjust the screen settings on the display settings screen or take off your sunglasses.
- When  is displayed on the screen, select  to return to the previous screen.

### Capacitive touch screen buttons

The operable areas of the capacitive touch screen buttons use capacitive touch sensors and may not operate properly in the following situations:

- If the screen is dirty or wet
- If a source of strong electromagnetic waves is brought near the screen
- If a glove is worn during operation
- If the screen is touched by a fingernail
- If a stylus is used to operate the buttons
- If your palm touches the operable area of another button during

operation

- If a button is touched quickly
  - If the operable part of a capacitive touch screen button is touched by or covered with a metal object, such as the following, it may not operate properly:
    - Magnetic isolation cards
    - Metallic foil, such as the inner packaging of a cigarette box
    - Metallic wallets or bags
    - Coins
    - Discs, such as a CD or DVD
  - If the operable part of a capacitive touch screen button is wiped, it may operate unintentionally.
  - If the capacitive touch screen button is being touched when the engine switch <power switch> is changed to ACC or ON, the button may not operate properly. In this case, remove anything touching the button, turn the engine switch <power switch> off and then turn it to ACC or ON, or restart the system by press and hold the "POWER VOLUME" knob for 3 seconds or more.
- 
- Capacitive touch screen button sensor sensitivity can be adjusted. (→P.57)

### Home screen operation

**On the home screen, multiple screens, such as the audio/visual system screen, hands-free screen and clock screen, can be displayed simultaneously.**

### Home screen operation

- 1 Press the "HOME" button.

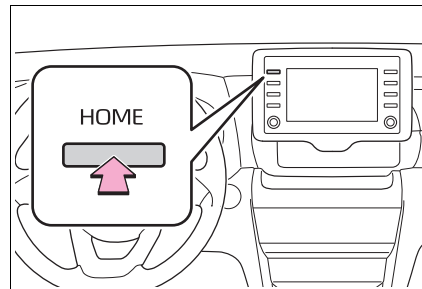

- 2 Check that the home screen is displayed.



- Selecting a screen will display it full screen.
- The display information and area on the home screen can be customize.
- The home screen can be set to several types of split layouts.

### Customizing the home screen

The display information/area on the home screen can be changed.

- 1 Press the "SETUP" button.

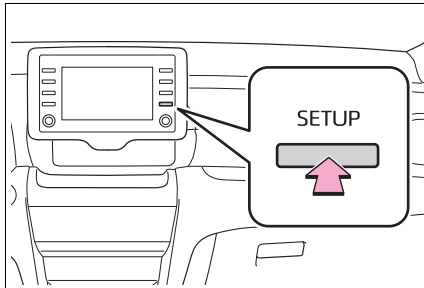

- If the general settings screen is not displayed, select "General".
- 2 Select "Customise home screen".
  - 3 Select the items to be set.

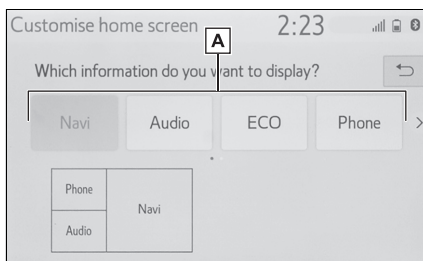

- A** Select to change the display information and area on the home screen.

### Entering letters and numbers/list screen operation

#### Entering letters and numbers

When searching by an address, name, etc., or entering data, letters and numbers can be entered via the screen.

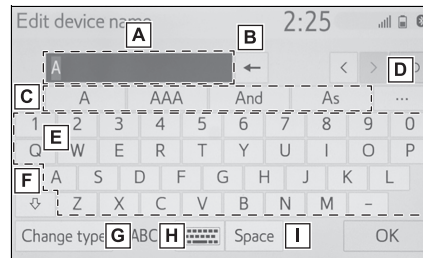

- A** Text field. Entered character(s) will be displayed.
- B** Select to erase one character. Select and hold to continue erasing characters.
- C** Select to choose a predictive text candidate for entered text.\* (→P.29)
- D** Select to display a list of predictive text candidates when there is more than one.\* (→P.29)
- E** Select to enter desired characters.
- F** Select to enter characters in lower case or in upper case.

- G** Select to change character types.
  - H** Select to change character types and keyboard layout.
  - I** Select to make a space on cursor.
- \*: These functions are not available in some languages.

- When **<>** is displayed, selecting it will move the cursor to the text field.

### Changing character type and keyboard layout

- 1 Select .



- 2 Select the desired character and keyboard and select "OK".

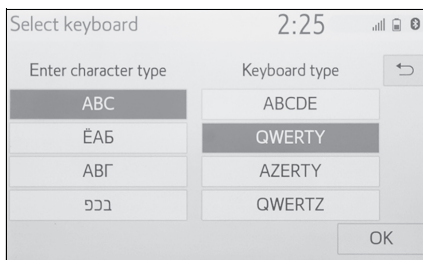

### Changing character type

- 1 Select "Change type".

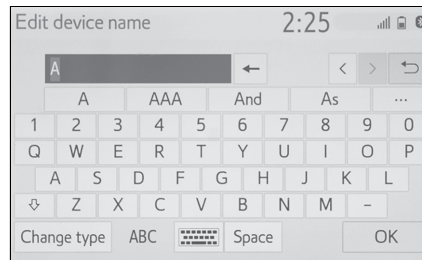

- 2 Select the desired character.

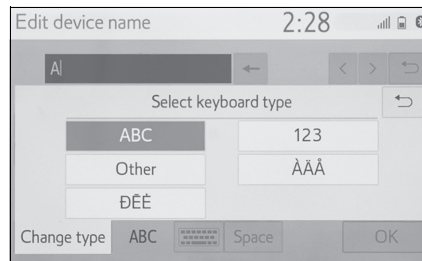

- Depending on the screen being displayed, it may not be possible to change keyboard characters.

### Displaying predictive text candidates\*

- \*: These functions are not available in some languages.

When text is input, the system predicts the text that may complete the currently unconfirmed text and displays predictive replacement candidates that match the beginning of the text.

- 1 Input text.

2

Basic function

2 Select the desired candidate.

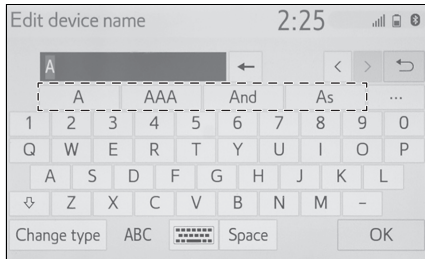

- To select a candidate that is not displayed, select **...**, and then select the desired predictive replacement candidate.

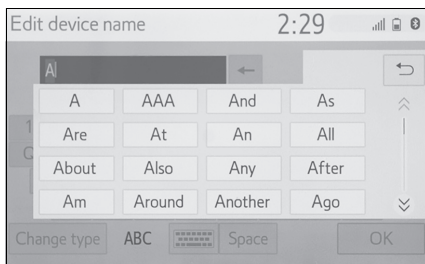

**List screen**

The list screen may be displayed after entering characters. When a list is displayed, use the appropriate screen button to scroll through the list.

**Scrolling list screen**

When a list is displayed, use the appropriate screen button to scroll through the list.



- A** To scroll up/down the list, flick the list up/down.
- B** Select to skip to the next or previous page. Select and hold to scroll through the displayed list.
- C** Indicates the position of the displayed entries in the entire list. To scroll up/down pages, drag the bar.

- If **>...** appears to the right of an item name, the complete name is too long to display.\*1
- Select **>...** to scroll to the end of the name.
- Select **<...** to move to the beginning of the name.
- Matching items from the database are listed even if the entered address or name is incomplete.
- The list will be displayed automatically if the maximum number of characters is entered or matching items can be displayed on a single list screen.
- The number of matching items is shown on the right side of the screen. If the number of matching items is more than 999, the system displays asterisk marks on the screen.\*2

\*1: These functions are not available in some languages.

\*2: If equipped

**Searching a list**

Items are displayed in the list with the most similar results of the search at the top.

1 Select .

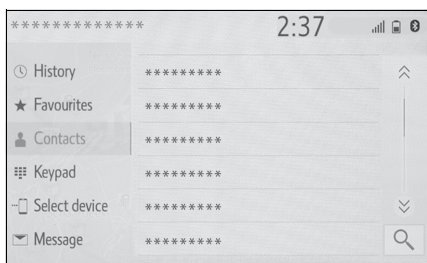

2 Input text.

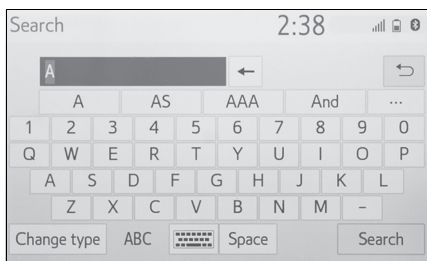

3 Select "Search".

- The list is displayed.

**Screen adjustment**

The contrast and brightness of the screen display and the image of the camera display can be adjusted. The screen can also be turned off, and/or changed to either day or night mode.

(For information regarding audio/visual screen adjustment: →P.117)

**Displaying the screen adjustment screen**

1 Press the "MENU" button.

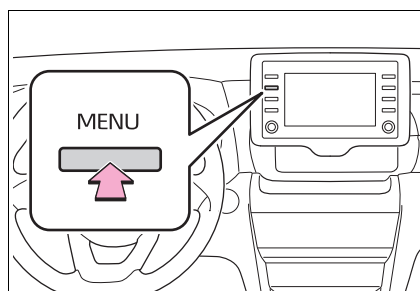

2 Select "Display".

3 Select the desired items to be set.

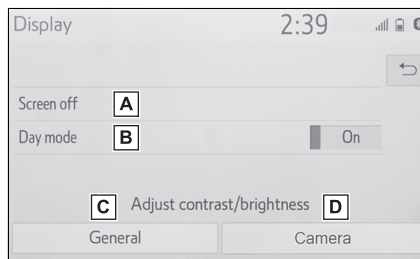

**A** Select to turn the screen off. To

turn it on, press any button.

**B** Select to turn day mode on/off.

(→P.32)

**C** Select to adjust the screen display. (→P.32)

**D** Select to adjust the camera display. (→P.32)

- 
- When the screen is viewed through polarized sunglasses, a rainbow pattern may appear on the screen due to optical characteristics of the screen. If this is disturbing, please operate the screen without polarized sunglasses.

#### **Changing between day and night mode**

Depending on the position of the headlight switch, the screen changes to day or night mode. This feature is available when the headlight is switched on.

**1** Select "Day mode".

- 
- If the screen is set to day mode with the headlight switch turned on, this condition is memorized even with the engine <hybrid system> turned off.

#### **Adjusting the contrast/brightness**

The contrast and brightness of the screen can be adjusted according to the brightness of your surroundings.

**1** Select "General" or "Camera".

**2** Select the desired item.

- "Display (General)" screen only:  
Select "<" or ">" to select the desired display.

- "Contrast"

"+": Select to strengthen the contrast of the screen.

"-": Select to weaken the contrast of the screen.

- "Brightness"

"+": Select to brighten the screen.

"-": Select to darken the screen.

### Linking multi-information display and the system

The following functions of the system are linked with the multi-information display in the instrument cluster:

- Phone \*
- Audio

etc.

**These functions can be operated using multi-information display control switches on the steering wheel. For details, refer to “Owner’s Manual”.**

\*: When an Apple CarPlay connection is established, this function will be unavailable.

2

Basic function

### Registering/Connecting a Bluetooth® device

To use the hands-free system, it is necessary to register a Bluetooth® phone with the system.

Once the phone has been registered, it is possible to use the hands-free system.

This operation cannot be performed while driving.

When an Apple CarPlay connection is established, Bluetooth® functions of the system will become unavailable and any connected Bluetooth® devices will be disconnected.

When connecting to Android Auto, a Bluetooth® connection will be made automatically.

When an Android Auto connection is established, some Bluetooth® functions other than hands-free system cannot be used.

### Registering a Bluetooth® phone for the first time

#### ■ Registering from the system

- 1 Turn the Bluetooth® connection setting of your cellular phone on.
  - This function is not available

when Bluetooth® connection setting of your cellular phone is set to off.

- 2 Press the "MENU" button.

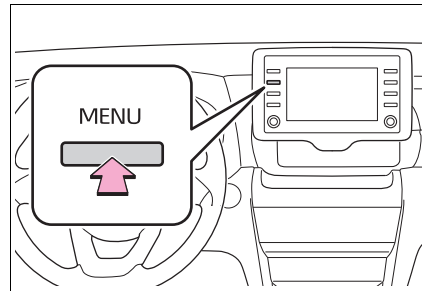

- 3 Select "Phone".

- Operations up to this point can also be performed by pressing the "PHONE" button on the instrument panel.

- 4 Select "Yes" to register a phone.

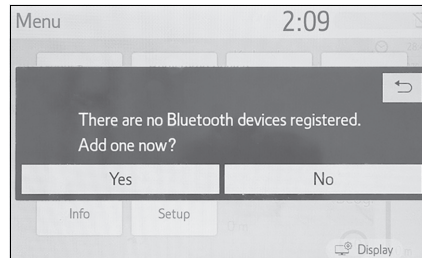

- 5 Select the desired Bluetooth® device.

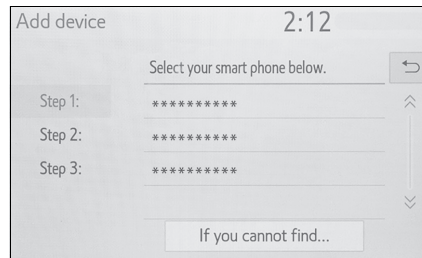

- If the desired Bluetooth® device

is not on the list, select “If you cannot find...” and follow the guidance on the screen to try again or register from the device. (→P.36)

**6 Register the Bluetooth® device using your Bluetooth® device.**

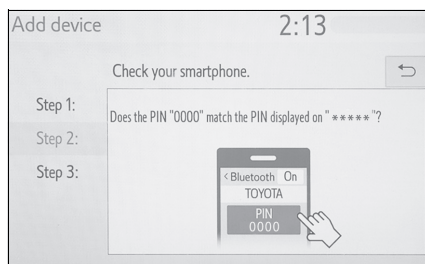

- For details about operating the Bluetooth® device, see the manual that comes with it.
- A PIN code is not required for SSP (Secure Simple Pairing) compatible Bluetooth® devices. Depending on the type of Bluetooth® device being connected, a message confirming registration may be displayed on the Bluetooth® device's screen. Respond and operate the Bluetooth® device according to the confirmation message.

**7 Check that the following screen is displayed, indicating pairing was successful.**

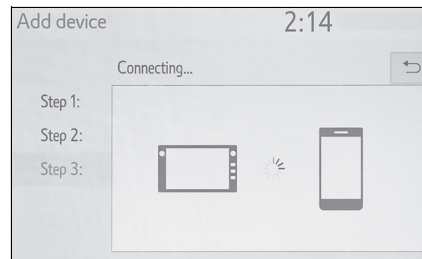

- The system is connecting to the registered device.
  - At this stage, the Bluetooth® functions are not yet available.
- 8 Check that “Connected” is displayed and registration is complete.**



- If an error message is displayed, follow the guidance on the screen to try again.
- If a cellular phone does not operate properly after being connected, turn the cellular phone off and on and then connect it again.

2

Basic function

■ **Registering from phone**

1 Select “If you cannot find...”.

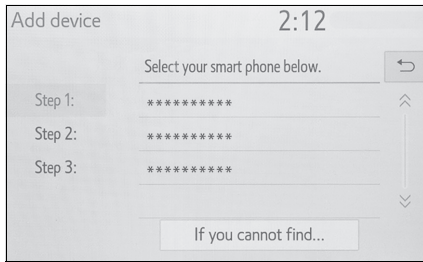

2 Select “Register from phone”.

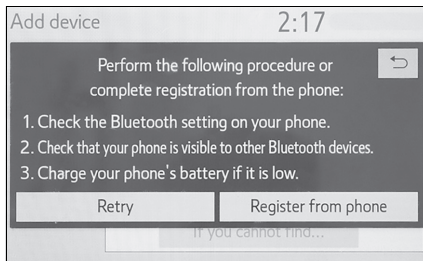

3 Check that the following screen is displayed, and register the Bluetooth® device using your Bluetooth® device.

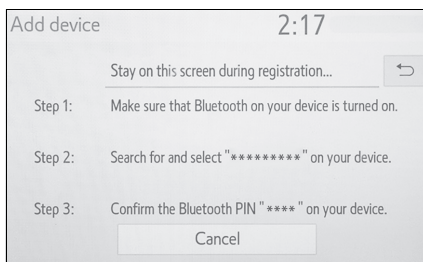

- For details about operating the Bluetooth® device, see the manual that comes with it.
- A PIN code is not required for SSP (Secure Simple Pairing) compatible Bluetooth® devices. Depending on the type of

Bluetooth® device being connected, a message confirming registration may be displayed on the Bluetooth® device’s screen. Respond and operate the Bluetooth® device according to the confirmation message.

4 Follow the steps in “Registering a Bluetooth® phone for the first time” from step 7. (→P.34)

**Registering a Bluetooth® audio player for the first time**

To use the Bluetooth® audio, it is necessary to register an audio player with the system.

Once the player has been registered, it is possible to use the Bluetooth® audio.

This operation cannot be performed while driving.

For details about registering a Bluetooth® device: →P.41

- 1 Turn the Bluetooth® connection setting of your audio player on.
- This function is not available when the Bluetooth® connection setting of your audio player is set to off.

2 Press the "AUDIO" button.

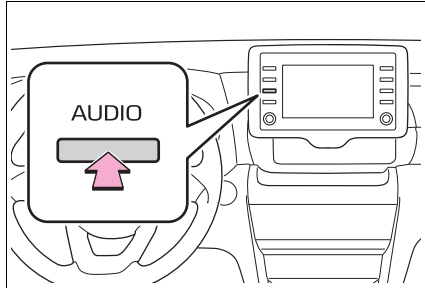

3 Select "Source" on the audio screen or press "AUDIO" button again.

4 Select "Bluetooth".

5 Select "Yes" to register an audio player.

6 Follow the steps in "Registering a Bluetooth® phone for the first time" from step 5. (→P.34)

### Profiles

This system supports the following services.

#### ■ Bluetooth® Core Specification

- Ver. 1.1 (Recommended: Ver. 4.2)

#### ■ Profiles:

- HFP (Hands Free Profile) Ver. 1.0 (Recommended: Ver. 1.7)
  - This is a profile to allow hands-free phone calls using a cellular phone. It has outgoing and incoming call functions.
- OPP (Object Push Profile) Ver. 1.1 (Recommended: Ver. 1.2)
  - This is a profile to transfer contacts

data.

- PBAP (Phone Book Access Profile) Ver. 1.0 (Recommended: Ver. 1.2)

- This is a profile to transfer phone-book data.

- MAP (Message Access Profile) Ver. 1.0 (Recommended: Ver. 1.2)

- This is a profile to use phone message functions.

- SPP (Serial Port Profile) Ver. 1.1 (Recommended: Ver. 1.2)

- This is a profile to use the Toyota online function.

- PAN (Personal Area Networking) Recommended: Ver. 1.0

- This is a profile to use the Toyota online function.

- A2DP (Advanced Audio Distribution Profile) Ver. 1.0 (Recommended: Ver. 1.3)

- This is a profile to transmit stereo audio or high quality sound to the audio/visual system.

- AVRCP (Audio/Video Remote Control Profile) Ver. 1.0 (Recommended: Ver. 1.6)

- This is a profile to allow remote control the A/V equipment.

- This system is not guaranteed to operate with all Bluetooth® devices.

- If your cellular phone does not support HFP, registering the Bluetooth® phone or using OPP, PBAP, MAP, SPP or PAN profiles individually will not be possible.

- If the connected Bluetooth® device version is older than recommended or

incompatible, the Bluetooth® device function may not work properly.

- Certification



Bluetooth is a registered trademark of Bluetooth SIG, Inc.

### Setting Bluetooth® details

#### Displaying the Bluetooth® setup screen

- 1 Press the “SETUP” button.

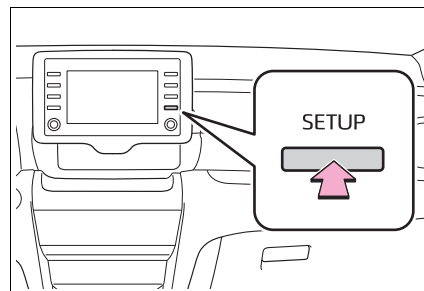

- 2 Select “Bluetooth”.
- 3 Select the desired item to be set.

#### Bluetooth® setup screen

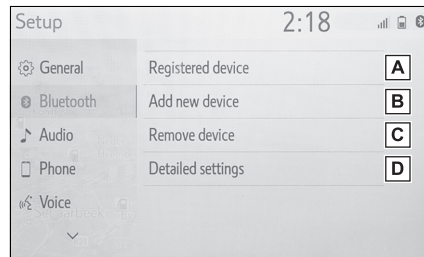

- A** Connecting a Bluetooth® device and editing the Bluetooth® device information (→P.39, 41)
- B** Registering a Bluetooth® device (→P.41)
- C** Deleting a Bluetooth® device

(→P.41)

### D Setting the Bluetooth® system

(→P.43)

- When an Apple CarPlay connection is established, this function will be unavailable.
- When an Android Auto connection is established, some functions will be unavailable.

### Connecting a Bluetooth® device

Up to 5 Bluetooth® devices (Phones (HFP) and audio players (AVP)) can be registered.

If more than 1 Bluetooth® device has been registered, select which device to connect to.

- 1 Display the Bluetooth® settings screen. (→P.38)
- 2 Select “Registered device”.
- 3 Select the device to be connected.

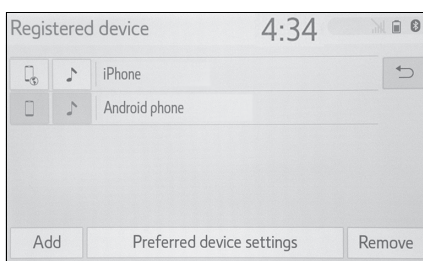

“Add”: Registering a Bluetooth® device (→P.41)

“Preferred device settings”: Select to change the automatic connection priority of the registered Bluetooth® devices. (→P.43)

“Remove”: Deleting a Bluetooth® device (→P.41)

: Phone

: Audio player

: Phone/Smartphone collaboration service

- The profile icon for a currently connected device will be displayed in colour.
  - Selecting a profile icon which is not currently connected will switch the connection to the function.
  - If the desired Bluetooth® device is not on the list, select “Add new device” to register the device. (→P.41)
- 4 Select the desired connection.

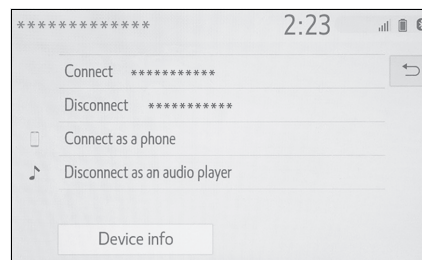

“Device info”: Select to confirm and change the Bluetooth® device information. (→P.41)

► When another Bluetooth® device is connected

- To disconnect the Bluetooth® device, select “Yes”.

- 5 Check that a confirmation screen is displayed when the connection is complete.

- If an error message is displayed, follow the guidance on the screen to try again.
- It may take time if the device connection is carried out during Bluetooth® audio playback.
- Depending on the type of Bluetooth® device being connected, it may be necessary to perform additional steps on the device.
- When disconnecting a Bluetooth® device, it is recommended to disconnect using this system.

**Connecting a Bluetooth® device in a different way (from phone top screen)**

→P.200

**Connecting a Bluetooth® device in a different way (from phone setup screen)**

→P.214

**Connecting a Bluetooth® device in a different way (from Bluetooth® audio screen)**

→P.133

■ **Auto connection mode**

To turn auto connection mode on, set “Bluetooth power” to on. (→P.43) Leave the Bluetooth® device in a location where the connection can be established.

- When the engine switch <power

switch> is turned to ACC or ON, the system searches for a nearby registered device.

- The system will connect with the registered device that was last connected, if it is nearby. When automatic connection priority is set to on and there is more than one registered Bluetooth® phone available, the system will automatically connect to the Bluetooth® phone with the highest priority. (→P.43)

■ **Connecting manually**

When the auto connection has failed or “Bluetooth power” is turned off, it is necessary to connect the Bluetooth® device manually.

- 1 Display the Bluetooth® settings screen. (→P.38)
- 2 Follow the steps in “Connecting a Bluetooth® device” from step 2. (→P.39)

■ **Reconnecting the Bluetooth® phone**

If a Bluetooth® phone is disconnected due to poor reception from the Bluetooth® network when the engine switch <power switch> is in ACC or ON, the system automatically reconnects the Bluetooth® phone.

### Registering a Bluetooth® device

Up to 5 Bluetooth® devices can be registered.

Bluetooth® compatible phones (HFP) and audio players (AVP) can be registered simultaneously.

This operation cannot be performed while driving.

- 1 Display the Bluetooth® settings screen. (→P.38)
- 2 Select “Add new device”.
  - ▶ When another Bluetooth® device is connected
    - To disconnect the Bluetooth® device, select “Yes”.
  - ▶ When 5 Bluetooth® devices have already been registered
    - A registered device needs to be replaced. Select “Yes”, and select the device to be replaced.
- 3 Follow the steps in “Registering a Bluetooth® phone for the first time” from step 5. (→P.34)

### Deleting a Bluetooth® device

This operation cannot be performed while driving.

- 1 Display the Bluetooth® settings screen. (→P.38)
- 2 Select “Remove device”.

- 3 Select the desired device.

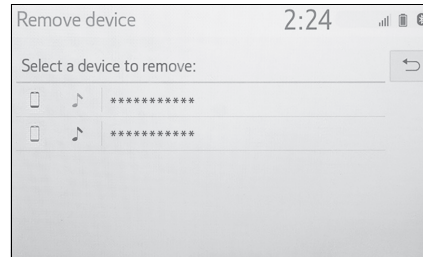

- 4 Select “Yes” when the confirmation screen appears.
- 5 Check that a confirmation screen is displayed when the operation is complete.

- When deleting a Bluetooth® phone, the contact data will be deleted at the same time.

### Editing the Bluetooth® device information

The Bluetooth® device's information can be displayed on the screen. The displayed information can be edited.

This operation cannot be performed while driving.

- 1 Display the Bluetooth® settings screen. (→P.38)
- 2 Select “Registered device”.
- 3 Select the desired device to be edited.

4 Select "Device info".

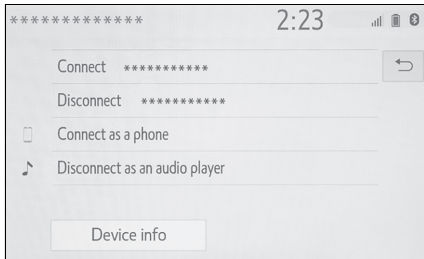

5 Confirm and change the Bluetooth® device information.

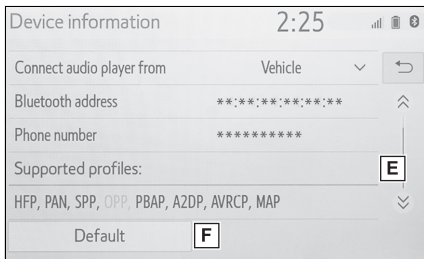
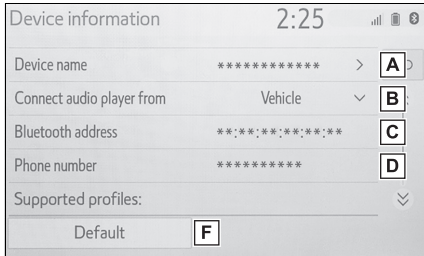

- A** The name of the Bluetooth® device. Can be changed to a desired name. (→P.42)
- B** Select to set the Bluetooth® audio player connection method. (→P.42)
- C** Device address is unique to the device and cannot be changed.
- D** Phone number of the Bluetooth®

phone.

- E** Compatibility profile of the Bluetooth® device.
- F** Select to reset all setup items.

- If 2 Bluetooth® devices have been registered with the same device name, the devices can be distinguished by referring to the device addresses.
- Depending on the type of phone, some information may not be displayed.

**Changing a device name**

- 1 Select "Device name".
- 2 Enter the name and select "OK".

- Even if the device name is changed, the name registered in your Bluetooth® device does not change.

**Setting audio player connection method**

- 1 Select "Connect audio player from".
- 2 Select the desired connection method.

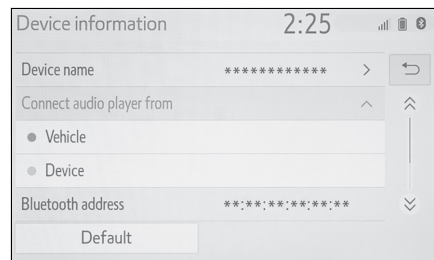

"Vehicle": Select to connect the audio player from the vehicle's audio/visual system.

“Device”: Select to connect the vehicle’s audio/visual system from the audio player.

- Depending on the audio player, the “Vehicle” or “Device” connection method may be best. As such, refer to the manual that comes with the audio player.

### “Detailed settings” screen

The Bluetooth® settings can be confirmed and changed.

- 1 Display the Bluetooth® settings screen. (→P.38)
- 2 Select “Detailed settings”.
- 3 Select the desired item to be set.

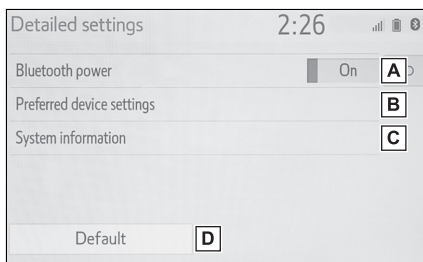

- A** Select to set Bluetooth® connection on/off. (→P.43)
- B** Select to change the automatic connection priority of the registered Bluetooth® devices. (→P.43)
- C** Select to edit the system information. (→P.44)
- D** Select to reset all setup items.

### Changing “Bluetooth power”

- 1 Select “Bluetooth power”.

When “Bluetooth power” is on:

The Bluetooth® device is automatically connected when the engine switch <power switch> is turned to ACC or ON.

When “Bluetooth power” is off:

The Bluetooth® device is disconnected, and the system will not connect to it next time.

- While driving, the auto connection state can be changed from off to on, but cannot be changed from on to off.

### Setting automatic connection priority

The automatic connection priority of the registered Bluetooth® devices can be changed.

- 1 Select “Preferred device settings”.
- 2 Select the desired item to be set.

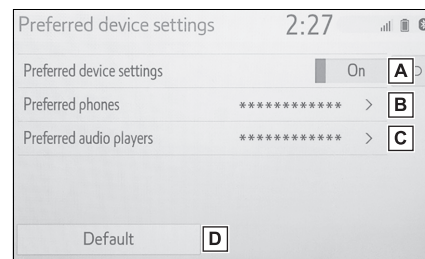

- A** Select to set automatic connection priority on/off.

2

Basic function

**B** Select to change the automatic connection priority of the registered Bluetooth® phones.  
(→P.44)

**C** Select to change the automatic connection priority of the registered Bluetooth® audio players.  
(→P.44)

**D** Select to reset all setup items.

**■ Changing Bluetooth® device automatic connection priority**

**1** Select “Preferred phones” or “Preferred audio players”.

**2** Select the desired Bluetooth® device and select “Move up” or “Move down” to change the preferred order.

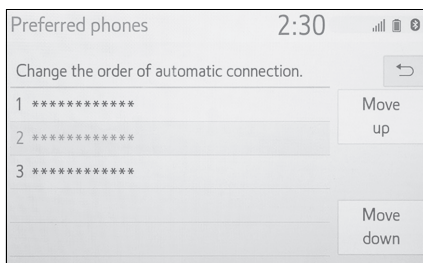

● A newly registered Bluetooth® device will automatically be given the highest automatic connection priority.

**Editing the system information**

**1** Select “System information”.

**2** Select the desired item to be set.

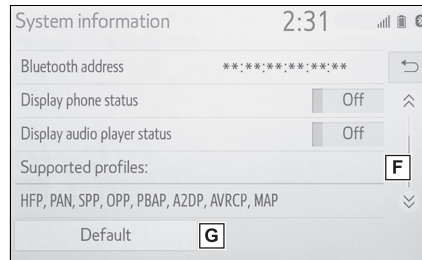
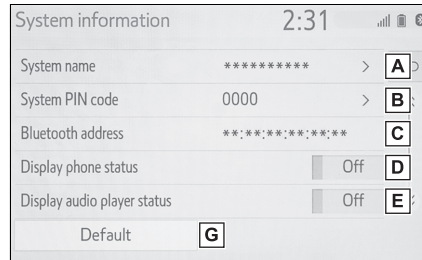

**A** Displays system name. Can be changed to a desired name.  
(→P.45)

**B** PIN code used when the Bluetooth® device was registered. Can be changed to a desired code. (→P.45)

**C** Device address is unique to the device and cannot be changed.

**D** Select to set the connection status display of the phone on/off.

**E** Select to set the connection status display of the audio player on/off.

**F** Compatibility profile of the system

**G** Select to reset all setup items.

### ■ Editing the system name

- 1 Select "System name".
- 2 Enter a name and select "OK".

### ■ Editing the PIN code

- 1 Select "System PIN code".
- 2 Enter a PIN code and select "OK".

### Connecting to internet/Miracast® via Wi-Fi®

Miracast® and the Toyota online, etc. can be used using the Wi-Fi® function of the system.

### Displaying the Wi-Fi® settings screen

- 1 Press the "SETUP" button.

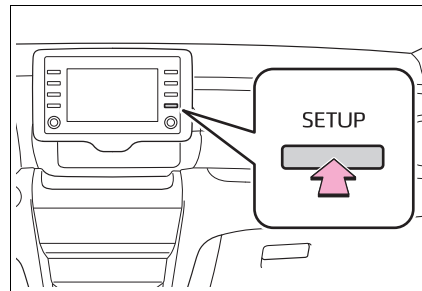

- 2 Select "Wi-Fi".
- 3 Select the items to be set.

### Wi-Fi® settings screen



2

Basic function

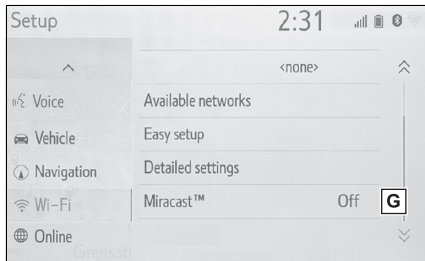

- A** Select to turn the Wi-Fi® function on/off. (→P.46)
- B** Select to access to network on/off. \*1
- C** Displays connected network name \*1
- D** Select to search for available networks that can be connected. \*1 (→P.46)
- E** Select to connect quickly to a WPS compatible Wi-Fi® device. \*1 (→P.47)
- F** Select to set the detailed Wi-Fi® settings. \*1 (→P.47)
- G** Displays status of the Miracast® connection. \*2

“On”: Connecting

“Off”: Not connecting

\*1: Models with navigation function

\*2: Miracast® status should be displayed only for Miracast® supported models.

### Turning Wi-Fi® function on/off

When turned on, “Available networks” and “Easy setup” can be selected.



- 1 Display the Wi-Fi® settings screen. (→P.45)
- 2 Select “Wi-Fi power”.
  - Each time “Wi-Fi power” is selected, the Wi-Fi® function is turned on/off.

### Connecting to a network

Available networks can be searched for and connected to.

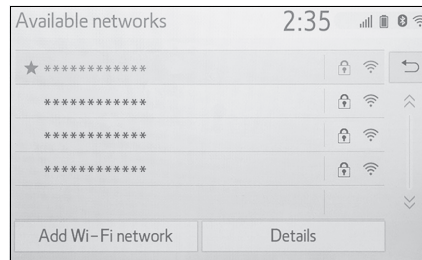
- 1 Display the Wi-Fi® settings screen. (→P.45)
- 2 Select “Available networks”.
- 3 Select the desired network.



- When a network with  is selected and the password enter screen is displayed, enter the password then select “OK”.
- The network that is selected Preferred Network is marked with .

“Details”: Select to display details about the network.

“Add Wi-Fi network”: Select to add a Wi-Fi® network that is not currently displayed.

### ■ Adding a Wi-Fi® network

Available networks which are not displayed by searching can be added.

- 1 Select “Add Wi-Fi network”.
- 2 Enter the network name and select “OK”.
- 3 Select the security type.
- 4 Enter the password and select “OK”.

### ■ Connecting quickly

If a Wi-Fi® device is Wi-Fi Protected Setup™ compatible, it can be connected to more quickly.

- 1 Display the Wi-Fi® settings screen. (→P.45)
- 2 Select “Easy setup”.
- 3 Select “PIN code” or “Push button” as determined by the device.

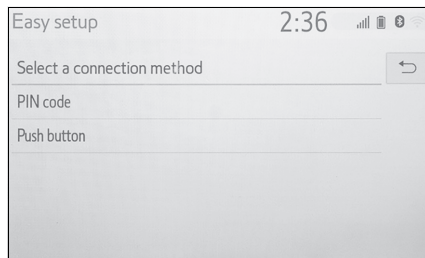

- 4 Operate the Wi-Fi® device to connect.

### ■ Detailed Wi-Fi® settings

- 1 Display the Wi-Fi® settings screen. (→P.45)
- 2 Select “Detailed settings”.
- 3 Select the desired items to be set.

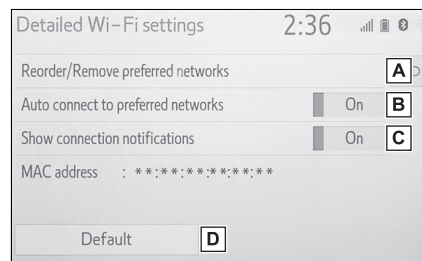

- A** Select to change the listing order of your preferred networks and to delete networks from the list. (→P.48)
- B** Select to set automatic connection to network on/off. When set to on, the system will automatically connect to the preferred networks that have been registered.
- C** Select to set the automatic connection message notification display on/off.
- D** Select to reset all setup items.

2

Basic function

**Preferred network settings**

Any network connected to in the past is set as a preferred network. The priority of the networks to connect to can be changed.

- 1 Select "Reorder/Remove preferred networks".
- 2 Select the desired network and select "Move up" or "Move down" to change the connection priority of the network.

"Remove": Select to delete a network.

- If a network is being connected to, preferred network settings cannot be changed.

**Wi-Fi® function operating hints**

- Wi-Fi® is a registered trademark of Wi-Fi Alliance®.
- If the vehicle is near a radio antenna, radio station or other source of strong radio waves and electrical noise, communication may be slow or impossible.

**! WARNING**

- Use Wi-Fi® devices only when safe and legal to do so.

- Your audio unit is fitted with Wi-Fi® antennas. People with implantable cardiac pacemakers, cardiac resynchronization therapy-pacemakers or implantable cardioverter defibrillators should maintain a reasonable distance between themselves and the Wi-Fi® antennas. The radio waves may affect the operation of such devices.

- Before using Wi-Fi® devices, users of any electrical medical device other than implantable cardiac pacemakers, cardiac resynchronization therapy-pacemakers or implantable cardioverter defibrillators should consult the manufacturer of the device for information about its operation under the influence of radio waves. Radio waves could have unexpected effects on the operation of such medical devices.

**Conditions displayed with Wi-Fi® icon**

Reception level appears on the right upper side of the screen. (→P.16)

**Specifications**

- Communication standards
  - IEEE 802.11b
  - IEEE 802.11g
  - IEEE 802.11n (2.4GHz)
- Security
  - WPA™
  - WPA2™
  - WEP\*

\*: Models without navigation function

- WPA™, WPA2™, Wi-Fi Protected

---

Setup™, and Miracast® are trademarks of Wi-Fi Alliance®.

2

Basic function

### Apple CarPlay/Android Auto\*

\*: This function is not made available in some countries or areas

**Apple CarPlay/Android Auto allows some applications, such as Map, Phone, and Music, to be used on the system.**

**When an Apple CarPlay/Android Auto connection is established, Apple CarPlay/Android Auto compatible applications will be displayed on the system display.**

- **Compatible devices**

Apple iPhone (iOS Ver. 9.3 or later) that supports Apple CarPlay.

For details, refer to <https://www.apple.com/ios/carplay/>.

Android devices with Android OS Ver. 5.0 or higher which support Android Auto and have the Android Auto application installed.

For details, refer to <https://www.android.com/auto/>.

### Establishing an Apple CarPlay connection

- 1 Enable Siri on the device to be connected.
- 2 Connect the device to the USB port. (→P.116)

- 3 Select “Always enable” or “Enable once”.
  - If “Do not enable” is selected, an Apple CarPlay connection will not be established. In this case, the device can be operated as a normal Apple device, such as an iPod. Apple CarPlay will remain disabled until “Preferred service” on the general settings screen is set to “Apple CarPlay”. (→P.57)
  - Depending on the device connected, it may take approximately 3 to 6 seconds before the system returns to previous screen.
  - The screen may change to step 6 depending on the system.
- 4 Press the “MENU” button.

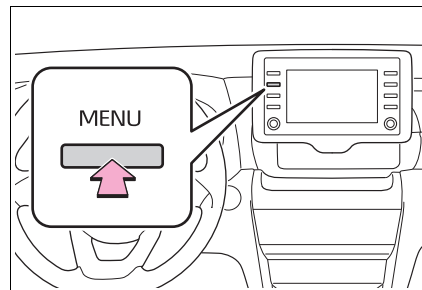

- 5 Select the “Apple CarPlay”.

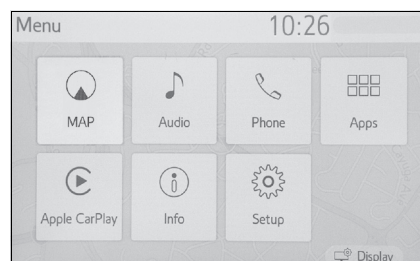

- 6** Check that home screen of Apple CarPlay is displayed.

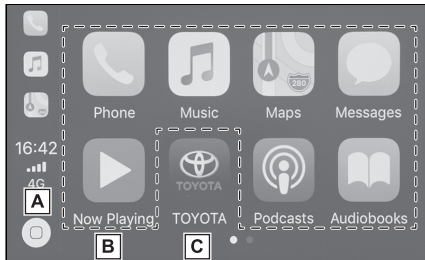

- A** Select to display the home screen of Apple CarPlay. Select and hold to activate Siri.
- B** Select to start the application. User can use any iPhone application supported by Apple CarPlay.
- C** Select to display the system screen.

### Establishing an Android Auto connection

- 1** Check that the Android Auto application is installed to the device to be connected.
- 2** Connect the device to the USB port. (→P.116)

- 3** Select “On” to enable the function.

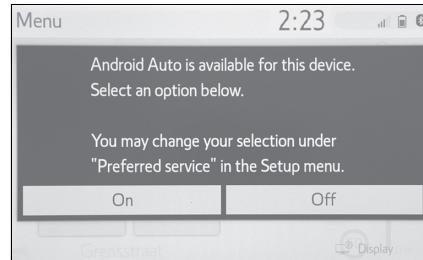

- “Off”: To enable Android Auto, set “Preferred service” on the general settings screen to “Android Auto”. (→P.57)
  - Depending on the device connected, it may take approximately 3 to 6 seconds before the system returns to previous screen.
  - The screen may change to step **6** depending on the system.
- 4** Press the “MENU” button.

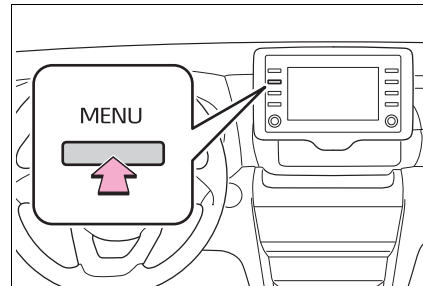

### 5 Select the “Android Auto”.

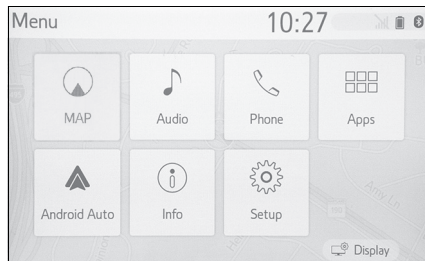

### 6 Check that home screen of Android Auto is displayed.

- When an Apple CarPlay/Android Auto connection is established, the function of some system buttons will change.
- When an Apple CarPlay/Android Auto connection is established, some system functions, such as the following, will be replaced by similar Apple CarPlay/Android Auto functions or will become unavailable:
  - iPod (Audio Playback)
  - USB audio/USB video
  - Bluetooth® audio
  - Bluetooth® phone (Apple CarPlay only)
- When an Android Auto connection is established while using Miracast®, Miracast® may become unavailable.
- The guidance volume can be changed on the voice settings screen. (→P.60) It cannot be changed by “POWER VOLUME” knob on Audio control panel.
- Apple CarPlay/Android Auto is an application developed by Apple Inc/Google LLC. Its functions and services may be terminated or changed without notice depending on the connected device’s operation system, hardware and software, or due to changes in Apple CarPlay/Android Auto specifications.
- For a list of the apps supported by Apple CarPlay or Android Auto, refer to their respective website.
- While using these functions, vehicle and user information, such as location and vehicle speed, will be shared with the respective application publisher and the cellular service provider.
- By downloading and using each application, you agree to their terms of use.
- Data for these functions is transmitted using the internet and may incur charges. For information about data transmission fees, contact your cellular service provider.
- Depending on the application, certain functions, such as music playback, may be restricted.
- As the applications for each function are provided by a third-party, they may be subject to change or discontinuation without notice. For details, refer to the website of the function.
- If the vehicle’s navigation system is being used for route guidance and a route is set using the Apple CarPlay/Android Auto Maps app, route guidance will be performed through Apple CarPlay/Android Auto. If the Apple CarPlay/Android Auto Maps app is being used for route guidance and a route is set using the vehicle’s navigation system, route guidance will be performed by the vehicle’s navigation system.
- If the USB cable is disconnected, operation of Apple CarPlay/Android Auto will end. At this time, sound output will stop and change to the system screen.



- Use of the Apple CarPlay logo means that a vehicle user interface meets Apple performance standards. Apple is not responsible for the operation of

this vehicle or its compliance with safety and regulatory standards. Please note that the use of this product with iPhone, iPod, or iPad may affect wireless performance.

- Apple CarPlay is a trademark of Apple Inc.

## androidauto

- Android™ and Android Auto™ are trademarks of Google LLC.



### WARNING

- Do not connect smartphone or operate the controls while driving.



### NOTICE

- Do not leave your smartphone in the vehicle. In particular, high temperatures inside the vehicle may damage the smartphone.
- Do not push down on or apply unnecessary pressure to the smartphone while it is connected as this may damage the smartphone or its terminal.
- Do not insert foreign objects into the port as this may damage the smartphone or its terminal.

### Troubleshooting

If you are experiencing difficulties with Apple CarPlay/Android Auto, check the following table.

| Symptom   | Solution   |
|---|--|
| An Apple CarPlay/Android Auto connection cannot be established.   | <p>Check if the device supports Apple CarPlay/Android Auto.</p> <p>Check if Apple CarPlay/Android Auto is enabled on the connected device.</p> <p>Check if that the Android Auto application is installed to the device to be connected.</p> <p>For details, refer to <a href="https://www.apple.com/ios/carplay/">https://www.apple.com/ios/carplay/</a>, <a href="https://www.android.com/auto/">https://www.android.com/auto/</a>.</p> <p>For available countries or areas for Apple CarPlay, refer to <a href="https://www.apple.com/ios/feature-availability/#apple-carplay">https://www.apple.com/ios/feature-availability/#apple-carplay</a>.</p> |
|   | <p>Check if “Apple CarPlay”/“Android Auto” of “Preferred service” on the general settings screen is set to on. (→P.57)</p>   |
|   | <p>Check if the USB cable being used is securely connected to the device and USB port.</p> <p>Try connecting the smartphone directly to the USB port in the vehicle, without using the hub.</p> <p>For Apple CarPlay: Check if the Lightning cable being used is certified by Apple and check if Siri is enabled.</p>  |
|   | <p>After checking all of the above, try to establish an Apple CarPlay/Android Auto connection. (→P.50)</p>   |
| When an Apple CarPlay/Android Auto connection is established and a video is being played, the video is not displayed, but audio is output through the system. | <p>As the system is not designed to play video through Apple CarPlay/Android Auto, this is not a malfunction.</p>  |

| Symptom   | Solution   |
|---|--|
| Although an Apple CarPlay/Android Auto connection is established, audio is not output through the system.   | The system may be muted or the volume may be low. Increase the system volume.  |
| The Apple CarPlay/Android Auto screen has artifacts and/or audio from Apple CarPlay/Android Auto has noise.   | Check if the USB cable being used to connect the device to the system is damaged. To check if the USB cable is damaged internally, connect the device to another system, such as a PC, and check if the device is recognized by the connected system. (The device should begin charging when connected.) |
|   | Replace the USB cable with another cable. (A short USB cable is recommended)   |
|   | After checking all of the above, try to establish an Apple CarPlay/Android Auto connection. (→P.50)  |
| The map display of the Apple CarPlay Maps app cannot be enlarged or contracted with pinch multi-touch gestures.   | As the Apple CarPlay Maps app is not compatible with pinch multi-touch gestures, this is not a malfunction.  |
| During Apple CarPlay music application (Apple Music, Spotify, etc.) playback, if the iPhone is operated to start and play audio from an application that is not compatible with Apple CarPlay* and the onboard device volume is changed, the audio of the incompatible application stops and the system resumes playback of the original music application. | This operation is performed according to the specification of the onboard device, this is not a malfunction.   |

| Symptom   | Solution   |
|---|--|
| After interrupt audio (such as navigation route guidance) is played from an application that is not compatible with Apple CarPlay while the onboard device is playing audio (FM/AM, CD, etc.), the system does not resume playback of the original audio (FM/AM, CD, etc.). | This operation is performed according to the specification of the onboard device, this is not a malfunction. Manually change the audio source by yourself. Or, do not use applications that are not compatible with Apple CarPlay.* Due to some navigation applications are compatible from iOS 12, update to the latest iOS and application versions. |
| When using Apple CarPlay, route guidance arrows and turn by turn navigation are not displayed on the multi-information display and system display. When using Android Auto, turn by turn navigation is not displayed on the multi-information display and system display.   | This is not a malfunction as display of these items is not possible with this function.  |
| When using Android Auto, hands-free call audio cannot be heard from the vehicle's speakers.   | Disconnect the phone from the USB cable and check if hands-free call audio can be heard using the hands-free system.   |
|   | Connect the phone to the system using Android Auto, turn up the volume on the system and check if hands-free call audio can be heard. Check if other sounds can be heard from the vehicle's speakers.  |

\*: Applications not compatible with Apple CarPlay are applications installed on the iPhone that are not displayed on the Apple CarPlay screen application list. (such as visual voicemail)

## General settings

Settings are available for clock, operation sounds, etc.

### Displaying the general settings screen

- 1 Press the "SETUP" button.

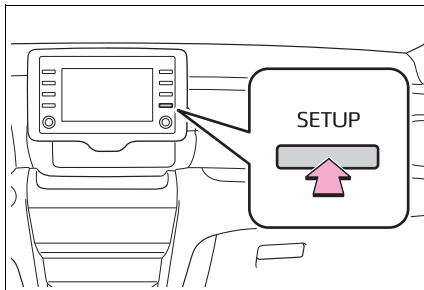

- If the general settings screen is not displayed, select "General".
- 2 Select the desired items to be set.

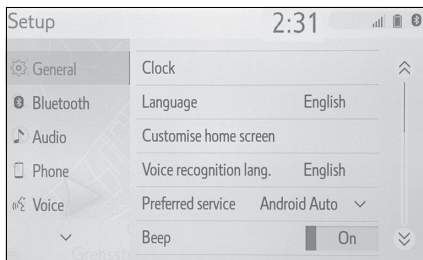

### General settings screen

- "Clock"

Select to change the time zone and select "On" or "Off" for daylight saving time, automatic adjustment of the clock, etc. (→P.58)

- "Language"

Select to change the language. The language settings of Apple CarPlay/Android Auto can only be changed on the connected device.

- "Customise home screen"

Select to customize the home screen. (→P.27)

- "Voice recognition lang."

Select to change the voice recognition language.

- "Preferred service"

Select to choose the service to launch when the smartphone is connected. (→P.59)

- "Beep"

Select to turn the beep sound on/off.

- "Theme setting"

Select to change the screen theme settings.

- "Units of measurement"

Select to change the unit of measure for distance/fuel consumption.

- "Auto change to screen"

Select to set automatic screen changes from the audio control screen to the home screen to on/off. When set to on, the screen will automatically return to the home screen from the audio control screen after 20 seconds.

- "Delete keyboard history"

Select to delete the keyboard history.

- "Memorise keyboard history"

Select to set the memorize keyboard history on/off.

- "Animation"

Select to set the animations on/off.

- "Delete personal data"

Select to delete personal data. (→P.59)

- “Software update”

Select to update software versions. For details, contact any Toyota retailer or Toyota authorized repairer, or any reliable repairer.

- “Gracenote database update”

Select to update Gracenote® database versions. For details, contact any Toyota retailer or Toyota authorized repairer, or any reliable repairer.

- “Software information”

Select to display the software information. Notices related to third party software used in this product are enlisted. (This includes instructions for obtaining such software, where applicable.)

- “SW sensitivity level”

Select to change the capacitive touch screen button sensitivity to 1 (low), 2 (medium), or 3 (high).

\*: Models with navigation function

### Clock settings

- 1 Display the general settings screen. (→P.57)
- 2 Select “Clock”.
- 3 Select the desired items to be set.

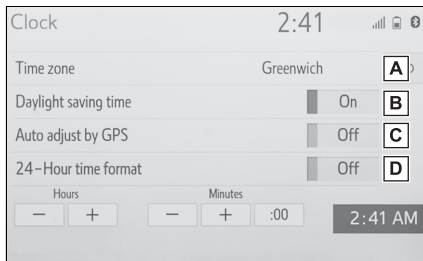

**A** Select to change the time zone. (→P.58)

**B** Select to set daylight saving time on/off.

**C** Select to set automatic adjustment of the clock by GPS on/off. When set to off, the clock can be manually adjusted. (→P.58)

**D** Select to set the 24 hour time format on/off. When set to off, the clock is displayed in 12 hour time format.

### Time zone

- 1 Select “Time zone”.
  - 2 Select the desired time zone.
- If “Other” is selected, the zone can be adjusted manually. Select “+” or “-” to adjust the time zone.

### Manual clock setting

When “Auto adjust by GPS” is turned off, the clock can be manually adjusted.

- 1 Select “Auto adjust by GPS” to set to off.

## 2 Adjust the clock manually.

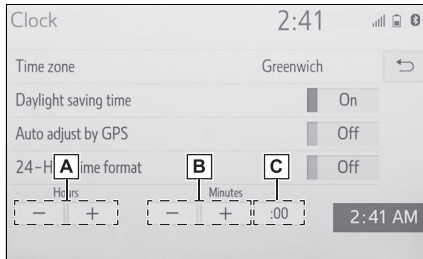

**A** Select “+” to set the time forward one hour and “-” to set the time back one hour.

**B** Select “+” to set the time forward one minute and “-” to set the time back one minute.

**C** Select to round to the nearest hour.

e.g.

1:00 to 1:29 → 1:00

1:30 to 1:59 → 2:00

### Preferred service settings

- 1 Display the general settings screen. (→P.57)
- 2 Select “Preferred service”.
- 3 Select the desired items to be set.

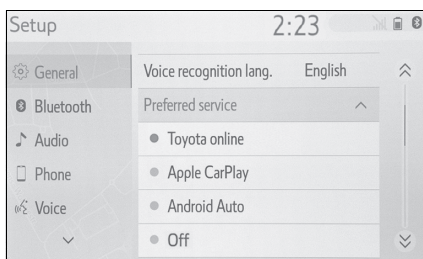

- This setting cannot be changed when a device is connected to the system via USB. Disconnect the device before attempting to change the setting.

### Deleting personal data

Registered or changed personal settings will be deleted or returned to their default conditions.

- 1 Display the general settings screen. (→P.57)
- 2 Select “Delete personal data”.
- 3 Select “Delete”.
- 4 Select “Yes” when the confirmation screen appears.

Examples of settings that can be returned to their default conditions:

- Navigation settings
- Audio settings
- Phone settings

etc.

2

Basic function

## Voice settings

Voice volume, etc. can be set.

### Displaying the voice settings screen

- 1 Press the "SETUP" button.

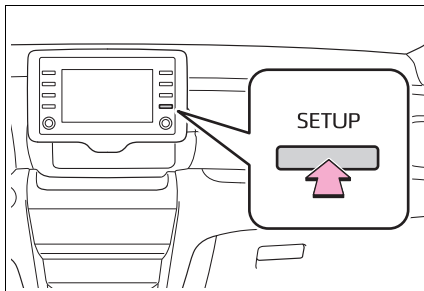

- 2 Select "Voice".
- 3 Select the desired items to be set.

### Voice settings screen

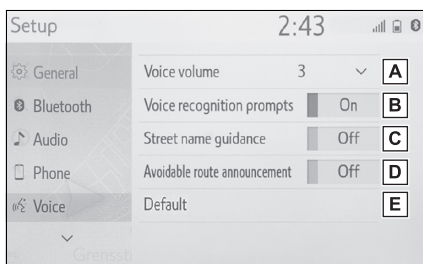

- A** Select to adjust the volume of voice guidance.
- B** Select to set the voice recognition prompts on/off.
- C** Select to set the street name guidance on/off.<sup>\*1</sup>

- D** Select to set the avoidable route announcement on/off.<sup>\*1</sup>

- E** Select to reset all setup items.<sup>\*2</sup>

<sup>\*1</sup>: Models with navigation function

<sup>\*2</sup>: Models without navigation function

## Vehicle settings

Settings are available for vehicle customisation and valet mode.

### Displaying the vehicle settings screen

- 1 Press the "SETUP" button.

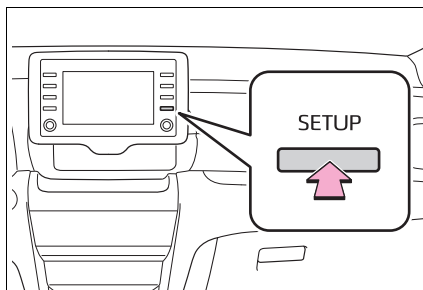

- 2 Select "Vehicle".
- 3 Select the desired items to be set.

### Vehicle settings screen

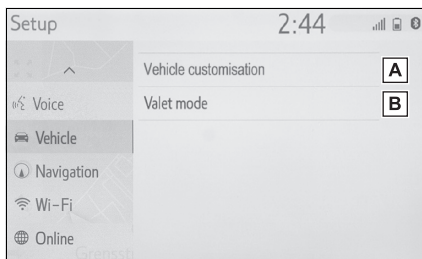

**A** Select to set vehicle customisation.\*

**B** Select to set valet mode.

(→P.61)

\*: Refer to the "Owner's Manual".

### Setting the valet mode

The security system can be set to on by entering a security code (4-digit number).

When set to on, the system will become inoperative once the electrical power source is disconnected until the security code is entered.

### Setting the valet mode

- 1 Display the vehicle settings screen. (→P.61)
- 2 Select "Valet mode".
- 3 Enter the 4-digit personal code and select "OK".
- 4 Enter the same 4-digit personal code again and select "OK".

- The system will request that you input the security code again to confirm that you remember it correctly.

- When valet mode activates, the system stops and a security code (4-digit number) standby screen is displayed. (→P.61)

- If the 4-digit personal code is forgotten, please contact any Toyota retailer or Toyota authorized repairer, or any reliable repairer.

### If the valet mode has been activated

- 1 Enter the 4-digit personal code and select "OK".

- If an incorrect security code (4-digit number) is entered 6 times, the system will not accept another security code (4-digit number) for 10 minutes.

## Navigation system

### 3

|  |     |
|--|-----|
| <b>3-1. Basic operation</b>                          |     |
| Navigation.....                                      | 64  |
| Map screen operation .....                           | 69  |
| Map screen information .....                         | 71  |
| Traffic messages .....                               | 75  |
| <b>3-2. Destination search</b>                       |     |
| Search operation .....                               | 78  |
| Starting route guidance .....                        | 87  |
| <b>3-3. Route guidance</b>                           |     |
| Route guidance .....                                 | 90  |
| Editing route .....                                  | 93  |
| <b>3-4. Favourite destinations</b>                   |     |
| Registering an entry .....                           | 98  |
| Editing the entry information<br>.....               | 100 |
| <b>3-5. Setup</b>                                    |     |
| Map settings .....                                   | 102 |
| Traffic message settings...                          | 105 |
| Route preferences settings<br>.....                  | 107 |
| <b>3-6. Tips for operating the navigation system</b> |     |
| GPS (Global Positioning System) .....                | 109 |
| Navigation database updates<br>.....                 | 111 |

For vehicles sold outside Europe, some of the functions cannot be operated while driving.

## Navigation\*

\*: Models with navigation function only

### Map screen

Map screen is displayed by following operation:

- Press the “MAP” button.
- Press the “MENU” button, then select “MAP”.

#### ■ After calculating a route to a new destination

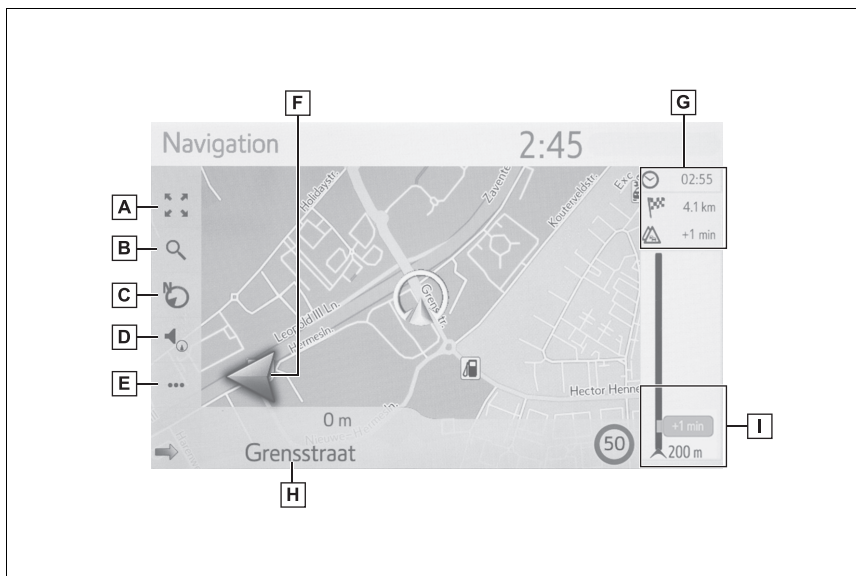

- A** Select to zoom in/out the map scale. (→P.69)
- B** Select to display the destination menu screen. (→P.67)
- C** Select to change the map layout. (→P.70)
- D** Select to adjust the volume of voice guidance. (→P.91)
- E** Select to display the action menu screen. (→P.65)
- F** Displays the distance to the next turn with the arrow indicating the turn direction. When the arrow icon is selected, the last navigation announcement will be repeated.

- G** Displays information about the destination, such as estimated arrival time, remaining travel time, distance, and traffic prediction information. Each time this area is selected, the information will change between the arrival time and remaining travel time to the destination.
- H** Displays the name of the current street or the next street.
- I** Displays traffic events on the route. The remaining length and the remaining delay time are displayed.

■ **Except for route guidance operation**

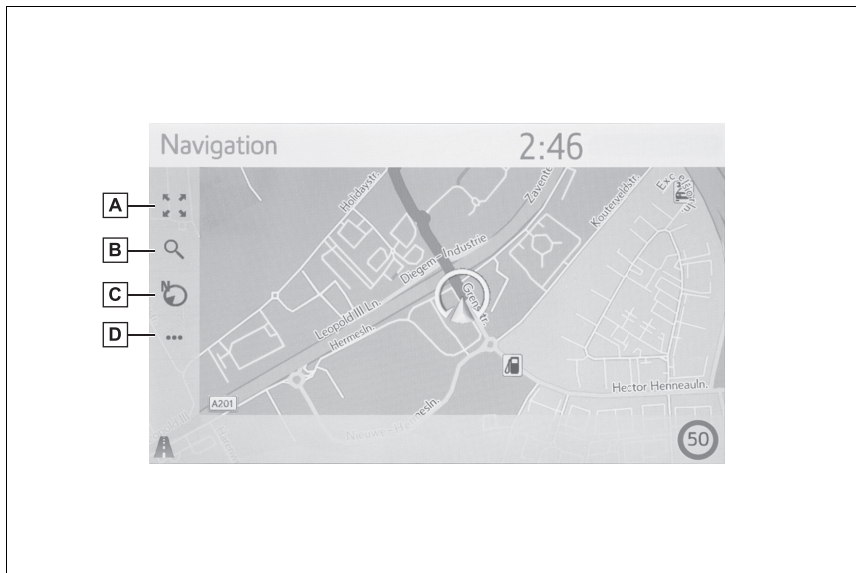

- A** Select to zoom in/out the map scale. (→P.69)
- B** Select to display the destination menu screen. (→P.67)
- C** Select to change the map layout. (→P.70)
- D** Select to display the action menu screen. (→P.65)

**Action menu screen**

To display the action menu screen, display the normal map screen (→P.64) and then select .

■ During route guidance operation

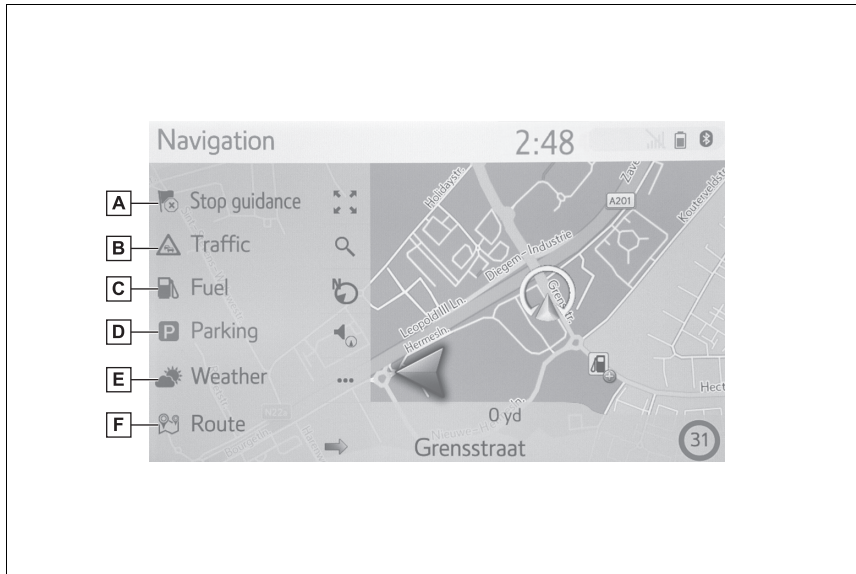

- A** Select to stop route guidance.
- B** Select to display the traffic messages. It displays a list of traffic messages relating to the set route, all traffic messages, and warnings. (→P.75)
- C** Select to display fuel station information. The location and fuel price can also be checked. (→P.237)
- D** Select to display parking lot information. The location, price and available spaces of parking lots can be checked. (→P.236)
- E** Select to display weather information. The weather information around the destination can be checked. (→P.235)
- F** Select to display the route information screen. Route options for the route calculations can be selected. (→P.93)

### ■ Except for route guidance operation

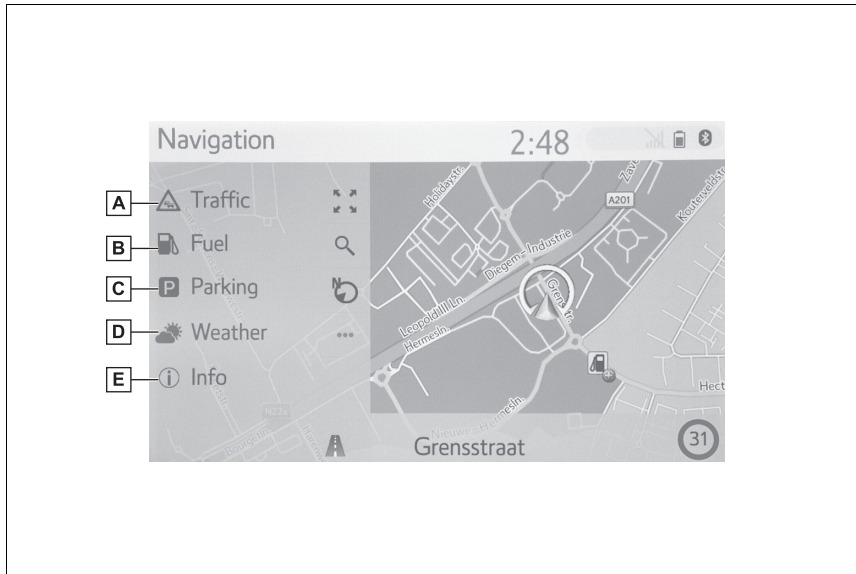

- A** Select to display the traffic messages. It displays a list of traffic messages relating to the set route, all traffic messages, and warnings. (→P.75)
- B** Select to display fuel station information. The location and fuel price can also be checked. (→P.237)
- C** Select to display parking lot information. The location, price and available spaces of parking lots can be checked. (→P.236)
- D** Select to display weather information. The weather information around different locations can be checked. (→P.235)
- E** Select to display the current position information screen. (→P.94)

### Destination menu screen

Destination menu screen is displayed by following operation:

- Press the “MENU” button, then select “MAP”.
- Select  on the map screen.

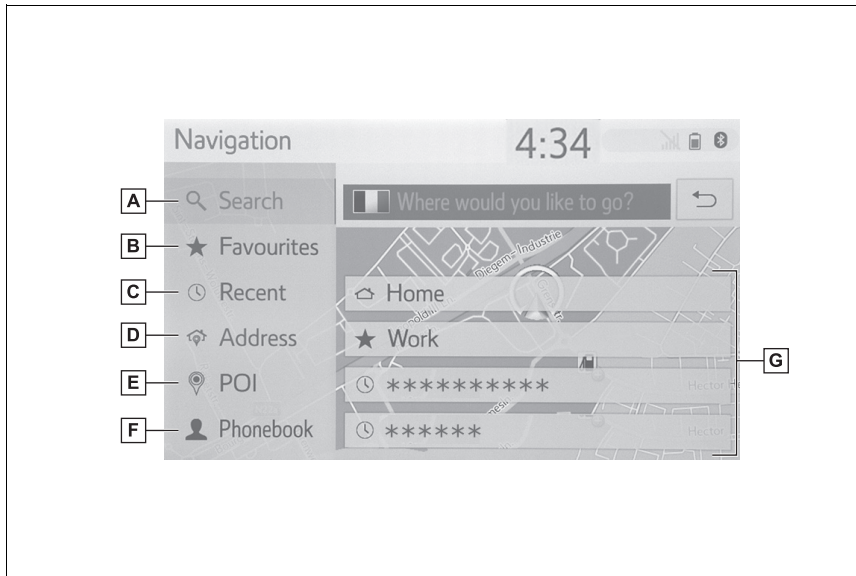

- A** Select to search for a destination by entering any search terms. (→P.78)
- B** Select to search for a destination and route from favourites list stored in the navigation system. (→P.80)
- C** Select to search for a destination from a list of the last destinations. (→P.82)
- D** Select to search for a destination by address or geo-coordinates. (→P.82)
- E** Select to search for a destination by POI (point of interest).
- F** Select to search for a destination from the phonebook of the connected Bluetooth® phone.
- G** Select to set a destination from quick access destinations. Home, Work and 2 last recent destinations are displayed as buttons and directly start the route guidance when selected.

## Map screen operation

### Current position display

- 1 Press the "MAP" button.

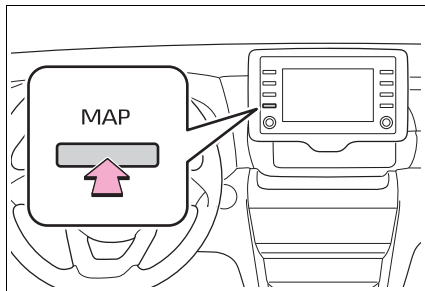

- 2 Check that the current position map is displayed.

- While driving, the current vehicle position mark is fixed on the screen and the map moves.
- The current position is automatically set as the vehicle receives signals from the GPS (Global Positioning System). If the current position is not correct, it is automatically corrected after the vehicle receives signals from the GPS.
- After the battery disconnection, or on a new vehicle, the current position may not be correct. As soon as the navigation system receives signals from the GPS, the correct current position is displayed.

### Map scroll operation

The map can be scrolled to view locations that are different than your current position.

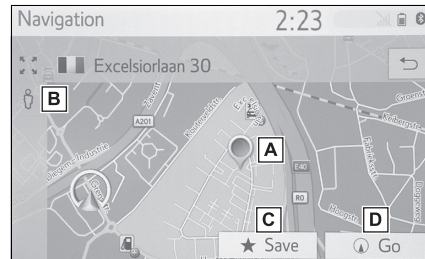

- A** Cursor mark
- B** Select to display the Street View.
- C** Select to register in favourites list. To change the icon, name, etc.: →P.100
- D** Select to set as a destination. (→P.87)

- The map screen can be scrolled by touching, dragging or flicking it. (→P.25)
- Press the "MAP" button to return to the current position.

### Map scale

- 1 Select  on the map screen. (→P.64)
- 2 Select "+" or "-" to change the scale of the map screen.

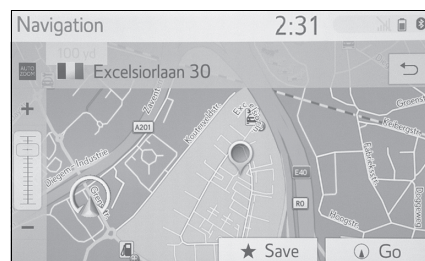

- The scale of the map screen can also be changed the following ways:
  - Dragging the scale bar marking to the desired point.
  - Pinch outward on the screen to zoom in and pinch inward to zoom out.
- Each time **AUTO ZOOM** is selected, the automatic map zoom is turned on/off. The default automatic zoom level can be selected. (→P.102)

- The scale range is from 10 m to 1000 km (10 yd. to 600 miles).
- After the scale has been changed, the new scale indicator will be displayed for a while.

### Map layout

The map layout can be changed between 3D heading-up, 2D heading-up and 2D north-up by selecting the map layout button.

- 1 Select the map layout button.



: 3D Heading-up symbol



The direction of vehicle travel is always up.

: Heading-up symbol

The direction of vehicle travel is always up.

: North-up symbol

Regardless of the direction of vehicle travel, north is always up.

- Each time map layout button is selected, the map layout changes as follows:  (3D heading-up) →  (2D heading-up) →  (2D north-up)

**Map screen information**

**Displaying various information on the map**

Various information can be displayed on the map.

**Speed limits\***

\*: If equipped

The speed limit of the road currently being traveled on can be displayed.

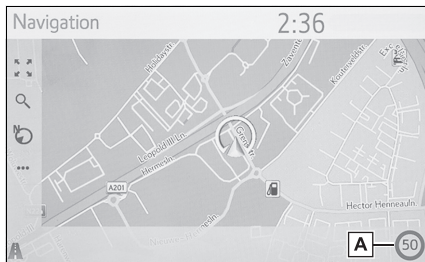

**A** Displays information about the speed limits icon and limited speed on the current road.

**3D buildings**

Buildings can be displayed in 3D on the map.

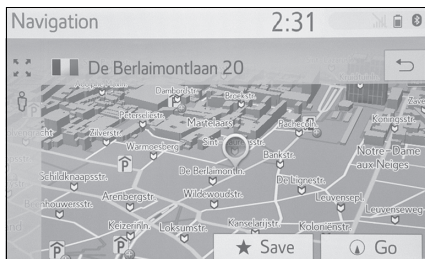

● This feature is displayed on the

map in zoom scales up to 50m (50yd.).

**3D landmarks**

Landmarks can be displayed in 3D on the map.



● This feature is displayed on the map in zoom scales up to 50m (50yd.).

**Safety cameras**

Safety cameras can be displayed as icons on the map.

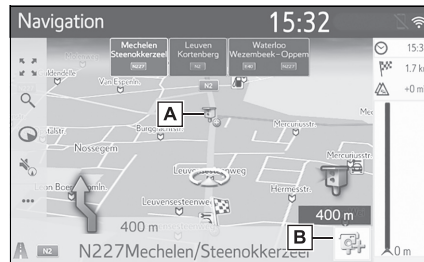

**A** Safety camera location on the map.

**B** Displays information about the safety camera icon and distance to safety camera.

● The above items will be displayed depending on the map scale.

- The above items will be displayed depending on the available map data.
- The displaying of the above items can be switched off. (→P.102)

**POI icons**

**Displaying POI icons**

POI (points of interest) icons such as petrol stations and restaurants can be displayed on the map screen. Their location can also be set as a destination.



- A particular type of POI icons displayed on the screen can be selected. (→P.104)

















**List of POI icons**



► Public

| Icon | Name                       |
|------|----------------------------|
|      | Library                    |
|      | College/University         |
|      | School                     |
|      | Tourist office             |
|      | Cemetery, funeral director |







| Icon | Name  |
|------|---|
|      | Government Office, Institution, City hall, Community gen. |
|      | Community   |
|      | Court house   |
|      | Place of Worship  |
|      | Accommodation, Hotel/Motel                                |
|      | Pharmacy  |
|      | Convention Centre, Exhibition Centre                      |
|      | Finance, Bank   |
|      | Cash Dispenser  |
|      | Post Office   |
|      | Business, B. Company, B. General, B. facility             |
|      | Medical, Doctor, Health & Care                            |
|      | Ambulance, Hospital/Poly-clinic                           |
|      | Fire Station  |
|      | Police Station  |
|      | Phone Box, Communication                                  |
|      | Dentist   |
|      | Veterinarian  |

## ► Traffic





| Icon  | Name   |
|---|--|
|    | Car Dealer/Repair, Repair Facility, Repair General, Car Wash, Tyre Repair      |
|    | Car Dealer   |
|    | Highway Exit   |
|    | Airport, Dep./Arrival, Ground, International, Domestic                         |
|    | Bus Terminal, Bus Stop, Transportation, Public Transp. Stop, Transport general |
|  | Railway Station  |
|  | Metropolitan Train   |
|  | Petrol Stations  |
|  | Rent-a-Car, -Facility, -Parking  |
|  | Ferry Terminal   |
|  | Parking, Open Parking Area, P. Area general                                    |
|  | Parking Garage   |
|  | Open P. A. P+R   |
|  | Rest Area  |
|  | Motoring Organization, Automobile Club   |
|  | Mover, Moving Company  |
|  | Motorcycle Dealer  |



| Icon  | Name           |
|---|----------------|
|  | Toyota Branded |
|  | Lexus Branded  |

## ► Clubbing

















| Icon  | Name  |
|---|---|
|    | Multiple POI  |
|    | Bar, Nightlife  |
|    | Leisure, Cultural Centre, Theatre, Music Centre, Concert Hall   |
|   | Cinema  |
|  | Casino  |
|  | Café/Bar, Café  |
|  | Restaurant, French, Belgian, Chinese, German, Greek, Vegetarian, Fast Food, Grill, Sea Food, Sandwich, Steak... |



## ► Sports

| Icon  | Name                                   |
|---|--|
|  | Sport, Sport General, sport activities |
|  | Golf Course                            |
|  | Race Track                             |
|  | Stadium, Sports Centre, Hippodrome     |
|  | Water Sports                           |

| Icon  | Name        |
|---|-------------|
|  | Bowling     |
|  | Ski resorts |

► Leisure

| Icon  | Name  |
|---|---|
|    | Amusement Park  |
|    | Winery  |
|    | Museum  |
|    | Shopping, Market Place, Shopping Centre, Factory Outlet |
|   | Shop, Department Store, Drive-through-bottle-shop       |
|  | Tourist Attractions, Important Tourist Attractions      |
|  | Park/Recreational Area                                  |
|  | Yacht Basin, Harbour                                    |
|  | Camping Ground  |
|  | Grocery Store   |
|  | Historical Monument                                     |
|  | RV Park, Camping  |
|  | Bookstore   |
|  | Hair & Beauty   |
|  | Photography   |
|  | Shoe store  |

| Icon  | Name               |
|---|--------------------|
|  | Wine & Liquor      |
|  | Clothing           |
|  | Cleaning & Laundry |

### Displaying POI information

- 1 Select the desired POI icon on the map.

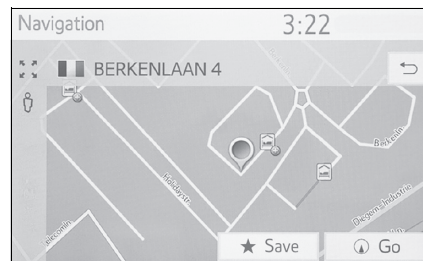

- If multiple POI's are available for the selected icon, select a POI name from the list.

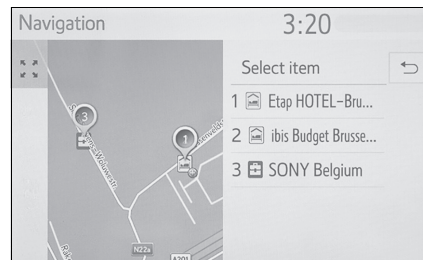

- 2 Check that the POI information is displayed.

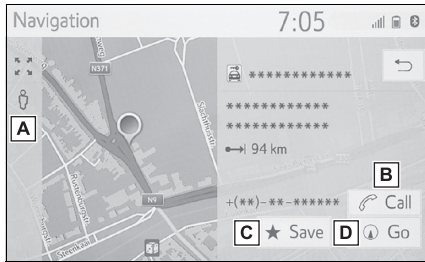

- A** Select to display the Street View. (→P.235)
- B** Select to call the registered phone number. (→P.207)
- C** Select to register the point in the favourites list. (→P.98)
- D** Select to display the starting route guidance screen. (→P.87)

### Traffic messages

Traffic messages such as traffic congestion, accidents and road closures are displayed on the map or the list. Traffic data can be received via radio broadcast or internet.

### Traffic messages screen

- ▶ Traffic message icons on the map



- ▶ Traffic message list

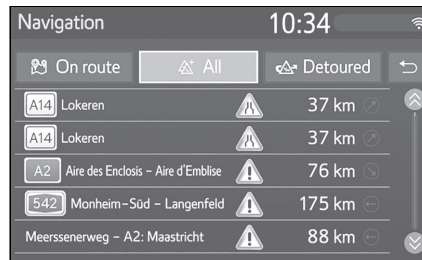

**Traffic message icon on the map**

■ **Displaying detailed traffic message**

- 1 Select the desired traffic message icon on the map.

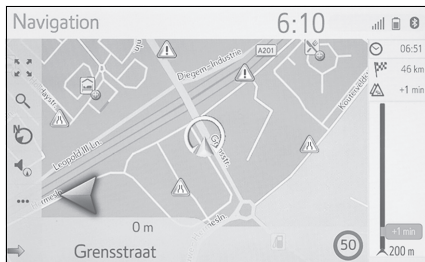

- 2 Check that the detailed traffic message is displayed.

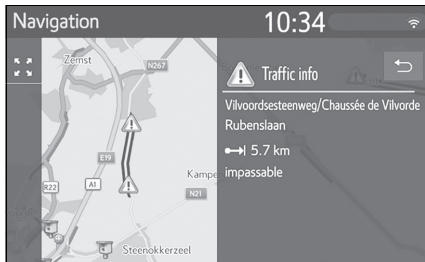

■ **List of traffic message icons**

| Icon | Name               |
|------|--------------------|
|      | Danger (Black)     |
|      | Weather            |
|      | Queuing traffic    |
|      | Stationary traffic |
|      | Accident           |
|      | Roadworks          |

| Icon | Name                 |
|------|----------------------|
|      | Road narrowness      |
|      | Extreme danger (Red) |
|      | Closed               |
|      | Information          |

**Traffic message list**

- 1 Select on the map screen. (→P.64)
- 2 Select “Traffic”.
- 3 Select the desired tab to select the list.

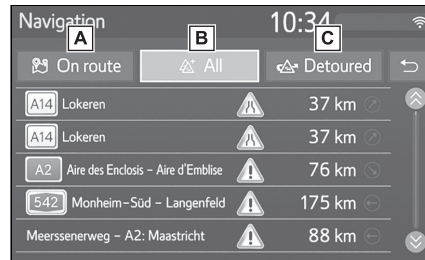

- A** Select to display the traffic messages relating to the set route.
- B** Select to display all traffic messages.
- C** Select to display traffic messages and warnings relating to the detour route.

- 4 Select the desired traffic message.

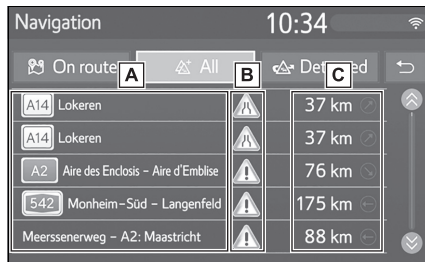



- B Displays the details of traffic message.

- A Route segment

If route segment is not available, information such as street name, city name, region or country will be displayed.

- B : Icon of an incident:

: Icon of an incident on the route

: Icon of an incident that is detoured

- C Distance to incident and direction from vehicle

- 5 Check that the detailed traffic message is displayed.

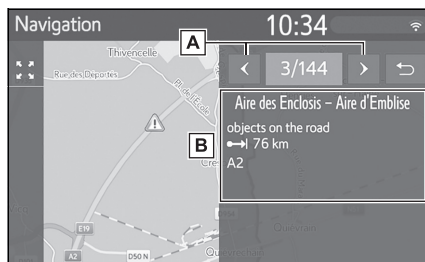

- A Select to display the previous or the next traffic message.

### Search operation

#### Displaying the destination menu screen

Destination searches can be done on the destination menu screen.

- 1 Press the "MAP" button.

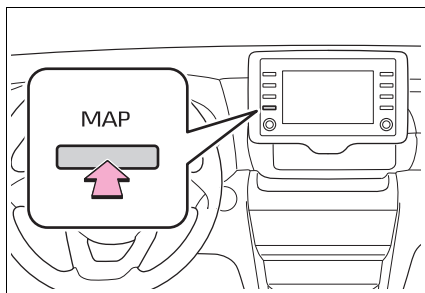

- 2 Select  on the map screen.
- 3 Check that the destination menu is displayed.

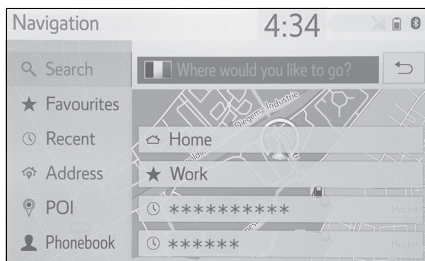

- There are different kinds of methods to search for a destination.

#### Searching from the search box

Destination can be selected by entering any search terms.

The search will locate the search

term in the following databases:

- Favourites
- Recent destination
- POI database
- Navigation database (street names, city names, country names)
- Phonebook from connected phone

- 1 Display the destination menu screen. (→P.67)
- To change the search country, select the country flag icon. (→P.79)
- 2 Enter the desired search terms in the search box.
  - When 3 or more characters are entered, the best match will be displayed in the single results box underneath the search box.

- 3 Select "Search" or  to show the result list.

- Select  to display the details screen. (→P.79)
- The result list shows up to 5 pages of results. More results can be seen by selecting "More results" at the end of the list.
- Each "Search POI via XX" triggers a search via a different search provider.

- For detailed setting about online search: →P.239

### Setting a country for search area

- 1 Select the country flag icon.

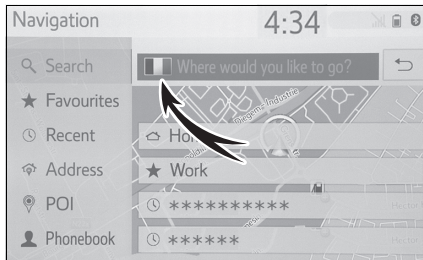

- 2 Enter a desired country name.
- 3 Select the desired country when the country candidate list is displayed.

### Viewing detail screen

If the result is a contact, street address, favourite or recent destination, the corresponding details screen is shown.

All details screens have “Go” button which starts route calculation and shows the route calculation screen.

- If a destination has already been set, “Replace”, “Add” and “Cancel” will be displayed.

“Replace”: Select to delete the existing destination(s) and set a new one.

“Add”: Select to add a destination to the current route.

“Cancel”: Select to return to the current destination.

- 1 Select the desired .



- 2 Check that the detailed POI information is displayed.

- If the result is a contact, favourite, recent destination or POI

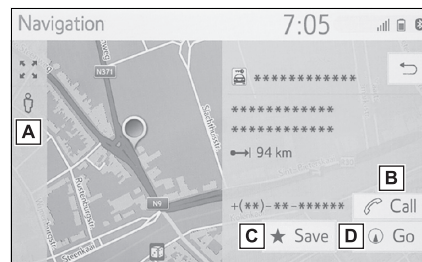

- Select to display the Street View.
- Select to call the phone number.
- Select to register the entry in the favourites list.
- Select to display the starting route guidance screen. (→P.87)

■ If the result is a street address



- A** Select to display the Street View.
- B** Select to enter the house number.
- C** Select to enter the intersection.
- D** Select to register the entry in the favourites list.
- E** Select to display the starting route guidance screen. (→P.87)



**Searching from favourites list**

Search for a destination and route from favourites list stored in the navigation system. To use this function, it is necessary to register the entry. (→P.98)

- 1 Display the destination menu screen. (→P.67)
- 2 Select "Favourites".

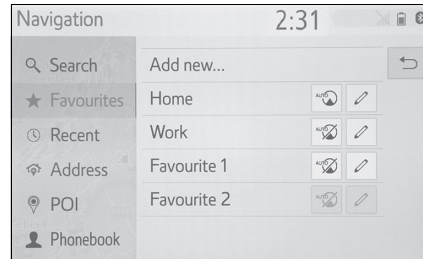
3 Select the desired entry.



- Select  to display and edit the entry information. (→P.100)
- Automatic navigation is available for the 4 fixed favourites (home, work, and 2 other favourites). When the automatic navigation is activated,  is turned on.
- 4 fixed favourites (home, work, and 2 other favourites) are displayed on the top of list.
- Transferred POIs and routes from an external device or the server will be stored in this list. (→P.99)
- Transferred routes are marked by the specific icon.

**Automatic navigation for commuting**

This feature automatically obtains traffic information on the route to the registered destinations. When you start the vehicle during a registered day/time slot, the system will propose to set that destination automatically.

- A pop-up message is displayed when you start the vehicle in reg-

istered day/time slot.

- Automatic navigation is available to the 4 fixed favourites (home, work, and 2 other favourites) only.
- To use this feature, it is necessary to register day/time slots for the destinations.

#### When the destination is not set

- ▶ Registered a day/time slot
  - 1 Select "OK" to start route guidance.
- If "Cancel" is selected, last active screen will display.
- ▶ Registered multiple day/time slot
  - 1 Select desired destination to start route guidance.

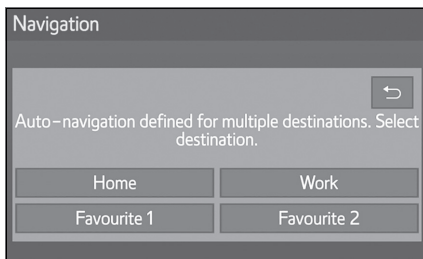

- If  is selected, last active screen will display.

#### When the destination is set

- ▶ Registered a day/time slot
  - 1 Select "Auto-navigation" to start route guidance.
- If "Continue" is selected, active route guidance will continue.

- ▶ Registered multiple day/time slot

- 1 Select "Auto-navigation" to start route guidance.
- If "Continue" is selected, active route guidance will continue.
- 2 Select desired destination to start route guidance.

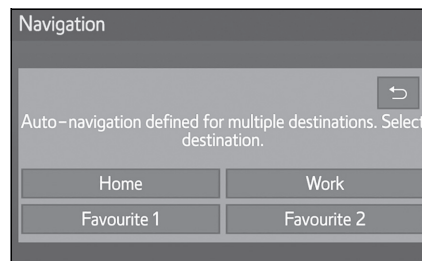

- If  is selected, last active screen will display.

#### Registering day/time slots

To use automatic navigation, it is necessary to register day/time slots for the destinations.

- 1 Select  of the desired destination.

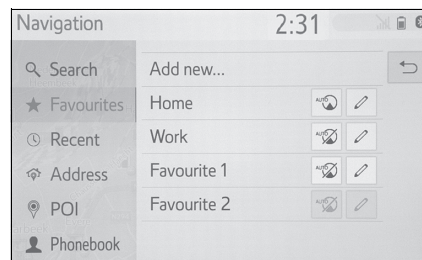

- 2 Enter the desired day and time information for the commutes.

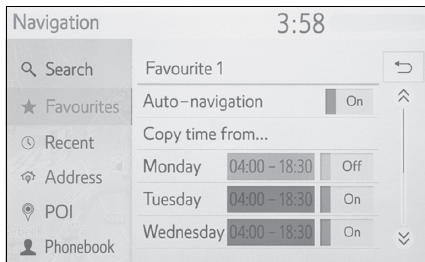

- Select "Auto-navigation" to set the automatic navigation on/off.
- Select the on/off to toggle auto-navigation setting on/off for specific days.
- Select "Copy time from..." to copy a defined time slot from one day to all other days.

### Searching from last destinations

- 1 Display the destination menu screen. (→P.67)
- 2 Select "Recent".
- 3 Select the desired entry.

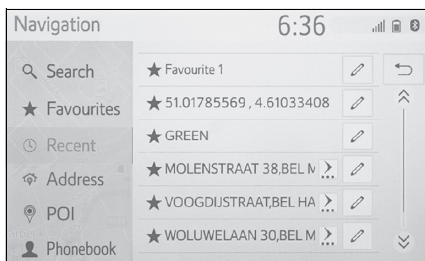

- Select to display and edit the entry information. (→P.100)
- Select to register the entry in

the favourites list.

- The list can contain a maximum of 100 entries. When the maximum is reached, the oldest destination is deleted.

### Searching by address

- 1 Display the destination menu screen. (→P.67)
- 2 Select "Address".
- 3 Select "Country" to enter the desired country.

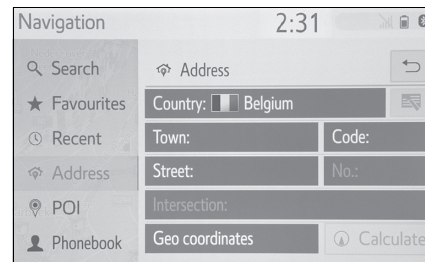

- 4 Select "Town", "Code" or "Street" to enter the town name, postal code or street name.
- 5 Select "No." or "Intersection" to enter a house number or intersection name.

- It is not possible to enter a house number and intersection at the same time.

- 6 Select "Calculate".

- If a unique street name is entered (only 1 in the country), then "Calculate" can also be selected. If "Calculate" is selected when only "Town" or "Code" has been entered, a route search starts with the centre of the town entered as the destination.

- When  is selected, entered data other than “Country” will be deleted.

### Searching by coordinates

Geo coordinates can be entered in DMS format (Degrees°, Minutes’, Seconds”) and Decimal. Only coordinate values that can potentially exist are able to be entered. Impossible coordinate values and their relevant screen buttons will be dimmed.

- 1 Select “Geo coordinates”.
- 2 Select “Degrees” or “Decimal”.
- 3 Enter the latitude and longitude.

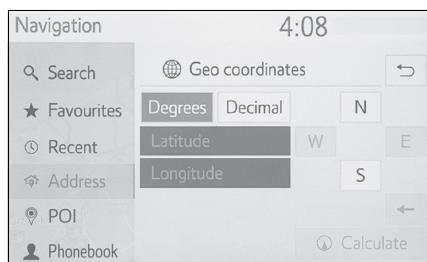

- 4 Select “Calculate”.

- If a destination that is not located on a road is set, the vehicle will be guided to the point on a road nearest to the destination.
- If a destination is set that cannot be reached, a pop-up will be displayed to indicate this.

### Searching by POIs

Search for a destination from POI database in the navigation system. When the navigation system is connected to the internet, a web search

is available.

- 1 Display the destination menu screen. (→P.67)
- 2 Select “POI”.
- 3 Enter the POI name and select “Search”.

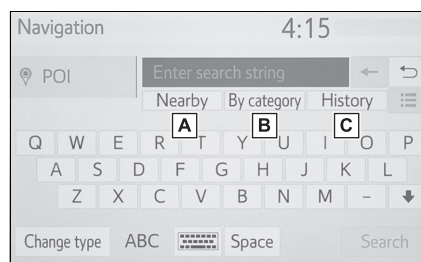

- A Select to change the searching area. (→P.84)
  - B Select to narrow down the POI category. (→P.84)
  - C Select to display the list of previous search word. (→P.85)
- 4 Check that the search results are displayed. Select the desired POI.

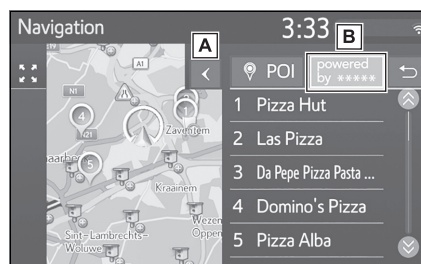

- A Select to display a full list view. The distance to the POIs can be checked.
- B Select to search for POIs using

web search. When you use web search for the first time, “Online” tab is displayed. Select “Online” tab to set a web search engine. For detailed setting about online search: →P.239

- 5 Check that the detailed POI information is displayed. (→P.79) Then select “Go”.

**Setting the search area**

- 1 Select “Nearby”, “At destination”, “Along route”, “In a town” or “Select on map” on the POI screen.

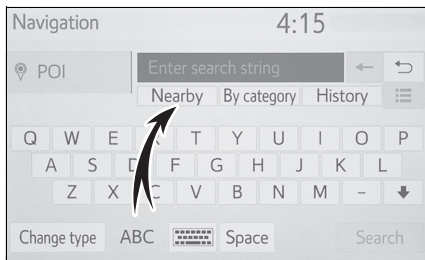

- The text on this button is always showing the current search criteria.
- 2 Select the desired search method.

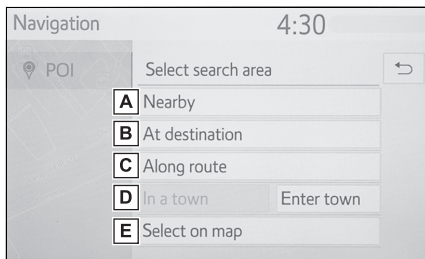

- A Select to set the search around

the current position.

- B Select to set the search around the destination.
- C Select to set the search around the current route.
- D Select to set the search around the desired town.
- E Select to set the point from the map.

- 3 If map screen is available, select the desired point on the map.

- 4 Enter the POI name and select “Search” or the list button.

- 5 Check that the search results are displayed. Select the desired POI.

- 6 Check that the detailed POI information is displayed. (→P.79) Then select “Go”.

**Searching by category**

- 1 Select “By category” on the POI screen.

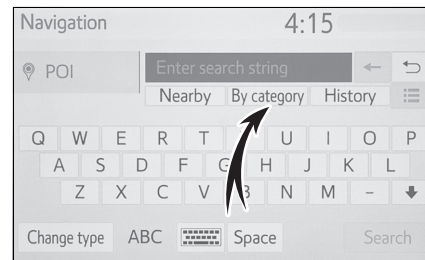

- 2 Select the desired category and subcategories.

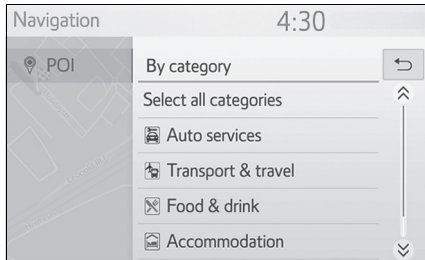

“Select all categories”: Select to display all POI categories.

- 3 Select the desired POI.
- 4 Check that the detailed POI information is displayed. (→P.79) Then select “Go”.

### Entering keywords from the history list

- 1 Select “History” on the POI screen.

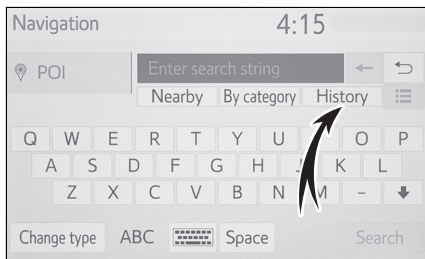

- 2 Select the desired previous search word.

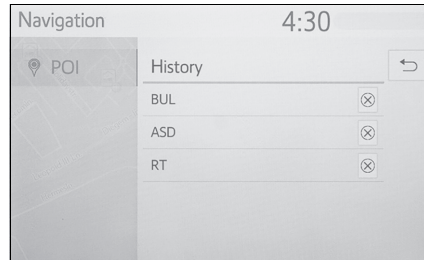

: Select to delete the search word.

- 3 Select “Search”.
- 4 Check that the search results are displayed. Select the desired POI.
- 5 Check that the detailed POI information is displayed. (→P.79) Then select “Go”.

### Display the online POI details

When the online search results is display, the pictures on the details screen is displayed.

- 1 Select the desired POI.
- 2 Check that the detailed POI information is displayed. Then select “Details”.

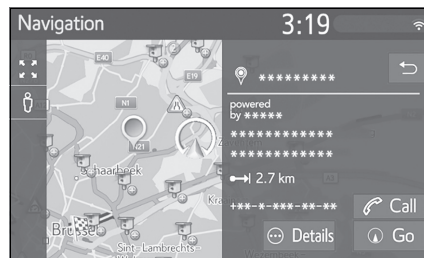

3 Select .

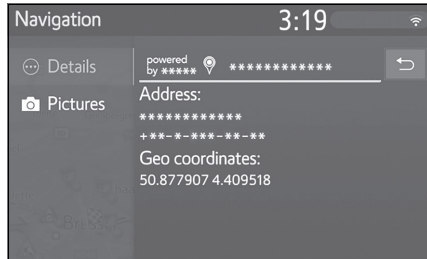

- Selecting the Pictures button displays up to 6 pictures as thumbnails in the screen. Selecting a thumbnail will enlarge the picture.

4 Select the desired thumbnail.

- The previous/next buttons are only shown if there is more than one picture available. If a picture can't be shown as enlarged, a message "Image is not available." will be displayed.

### Searching by phonebook

Before using this function, it is necessary to connect a Bluetooth® phone.

If a contact does not have address information stored, the entry will be dimmed.

- 1 Display the destination menu screen. (→P.67)
- 2 Select "Phonebook".

3 Select the desired entry.

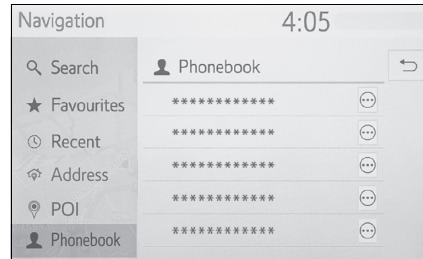

- Select  to display the details screen. (→P.79)

## Starting route guidance

### Starting route guidance

When the destination is set, the route overview from the current position to the destination is displayed.

Depending on the navigation settings, either a single route or route alternatives will be displayed on the screen. (→P.107)

#### ► Recommended route screen

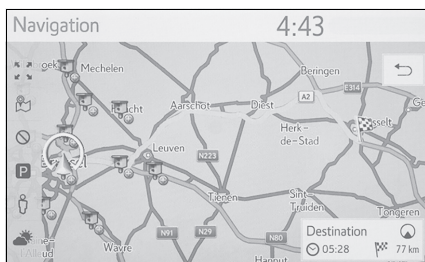

#### ► Route alternatives screen

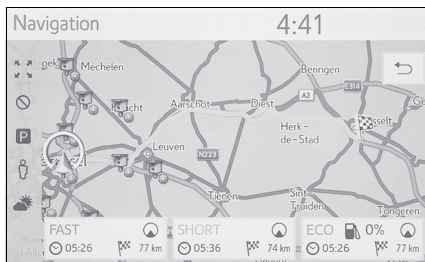

- The starting route guidance screen is displayed in 2D north-up.

### ! WARNING

- Be sure to obey traffic regulations and keep road conditions in mind while driving. If a traffic sign on the road has been changed, the route guidance may not indicate such changed information.

### Recommended route screen

The recommended route will be displayed on the map.

- 1 Select "Destination".

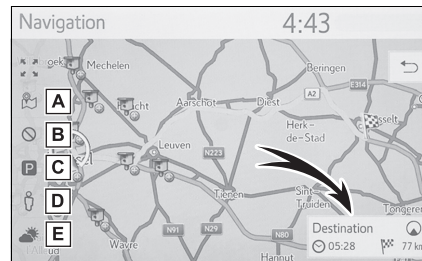

- A Select to display the three route calculation methods. Select the desired item to adjust the route preferences. (→P.88)
- B Select to display the avoidance criteria. Select the desired item to adjust the avoidance criteria. (→P.88)
- C Select to display parking lot information. The location and available spaces of parking lots around the destination can be checked. (→P.236)
- D Select to display the Street View. The Street View images of the destination can be viewed.

(→P.235)

**E** Select to display weather information. The weather information around the destination can be checked. (→P.235)

- Displays information about the destination, such as estimated arrival time and distance.
- 
- The default route preferences and avoidance criteria can be selected. (→P.107)
  - If “Destination” is selected and held, demo mode will start. Select “Quit” on the screen to end demo mode.

**Adjusting the route type**

- 1 Select .
- 2 Select the desired item to adjust the route preferences.

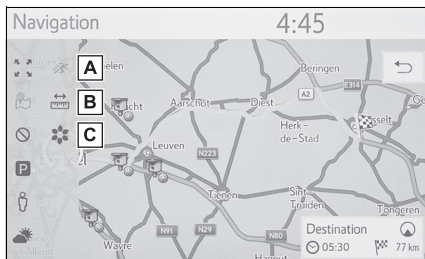

- A** Select to display the fastest route.
- B** Select to display the route that is the shortest distance to the set destination.
- C** Select to display the fuel-efficient route.
- The route will be recalculated

and then the starting route guidance screen will be displayed.

**Adjusting avoidance criteria**

- 1 Select .
- 2 Select the desired items to avoid.

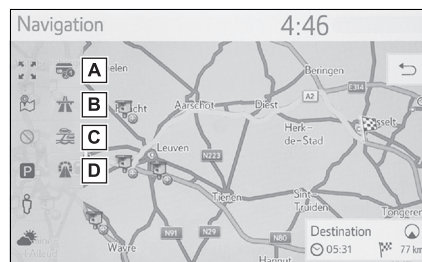

- A** Select to avoid the toll roads.
- B** Select to avoid the motorway.
- C** Select to avoid the ferry/train.
- D** Select to avoid the tunnel.

- The route will be recalculated and then the starting route guidance screen will be displayed. If the possible route is unreasonably long, the navigation system will propose a route including items selected to avoid.
- The default avoidance criteria can be selected. (→P.108)

**Route alternatives screen**

Three types of route alternatives will be displayed on the map.

- 1 Select one of the three types of route alternatives.

- Displays information about the destination, such as estimated arrival time and distance.

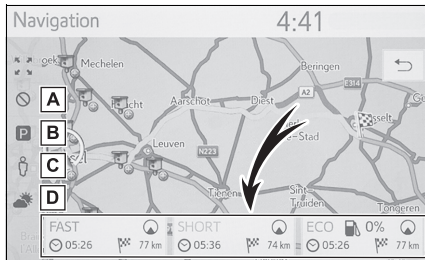

- A** Select to display the avoidance criteria. Select the desired item to adjust the avoidance criteria. (→P.88)
  - B** Select to display parking lot information. The location and available spaces of parking lots around the destination can be checked. (→P.236)
  - C** Select to display the Street View. The Street View images of the destination can be viewed. (→P.235)
  - D** Select to display weather information. The weather information around the destination can be checked. (→P.235)
- The estimated arrival time and distance of the entire route will be displayed in the list.

## Route guidance

### Route guidance screen

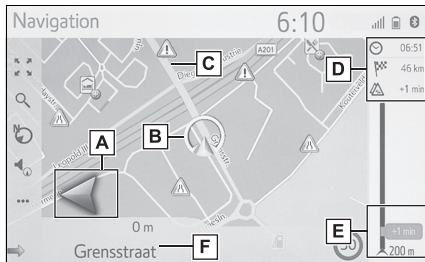

- A** Displays the distance to the next turn with the arrow indicating the turn direction. When the arrow icon is selected, the last navigation announcement will be repeated.
- B** Current position
- C** Guidance route
- D** Displays information about the destination, such as estimated arrival time, remaining travel time, distance, and traffic prediction information. Select to change the display estimated arrival time/remaining travel time.
- E** Displays traffic events on the route. The remaining length and the remaining delay time are displayed.
- F** The name of the current street or the next street (when approaching a turning point)

## During highway driving

During freeway driving, the highway information screen will be displayed.



- A** Name of the freeway exit/rest area.
- B** Distance from the current position to the freeway exit/rest area.
- C** POI's that are on the highway or close to a highway exit.

- Select desired POIs to display the selected map of the exit vicinity.
- Select a button at the bottom of the list allows to go back to displaying the nearest freeway exits/rest areas.

## Signposts\*

\* : If the data is available

When approaching the turn, a signpost will automatically be displayed.



**A** Displays information about the signposts.

**Motorway junction screen**

When approaching a motorway junction, junction view images will automatically be displayed.

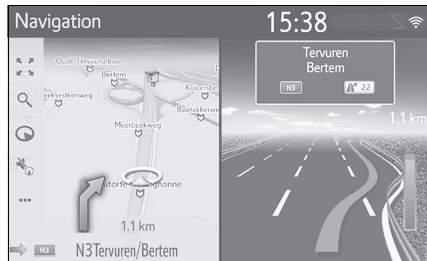

**Lane recommendation**

When approaching a turning point, the lane recommendation will automatically be displayed under the map.



**A** Displays the lane recommenda-

tion

- If the vehicle goes off the guided route, the route will be recalculated.
- For some areas, the roads have not been completely digitized in our database. Take care when following a guided route.
- The displaying of the above items can be switched off. (→P.102)

**Voice guidance**

The voice guidance provides various messages as you approach an intersection, or other points where maneuvering the vehicle is necessary. The voice guidance volume can be adjusted.

1 Select



2 Select the desired item.



**A** Select to adjust the volume of voice guidance.

- The voice guidance will be unmuted

by selecting while muting.

**B** Select to mute/unmute the voice guidance.

- The last navigation announcement can be repeated by selecting the voice guidance icon or changing the volume of voice guidance.

- The voice guidance may not pronounce certain street names correctly or clearly due to the limitations of the text-to-speech function.
- On motorways, interstates or other highways with higher speed limits, the voice guidance will be made at earlier points than on city streets in order to allow time to maneuver the vehicle.
- If the navigation system cannot determine the current vehicle position correctly (in cases of poor GPS signal reception), the voice guidance may be early or delayed.
- The default voice guidance volume can also be changed. (→P.60)

**⚠ WARNING**

- Be sure to obey the traffic regulations and keep the road condition in mind especially when you are driving on IPD roads (roads that are not completely digitized in our database). The route guidance may not have the updated information such as the direction of a one way street.

**Stopping route guidance**

When route guidance is no longer necessary, such as when you know the rest of the route to your destination, the route guidance can be stopped.

- 1 Select **⋮** on the map screen. (→P.64)
- 2 Select “Stop guidance”.

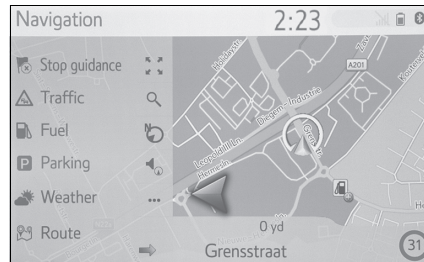

## Editing route

### Displaying the edit route screen

During route guidance, the route to the destination can be checked and edited.

- 1 Select the  on the map screen. (→P.64)
  - 2 Select "Route".
  - 3 Select the desired items to be set.
- ▶ When a destination is set

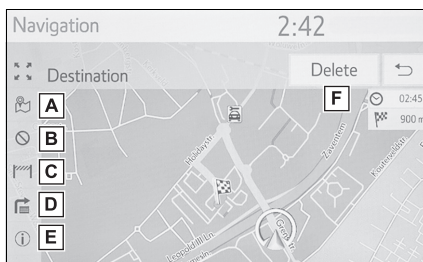

- A** Select to display the three route calculation methods. Select the desired item to adjust the route preferences. (→P.88)
- B** Select to display the avoidance criteria. Select the desired item to adjust the avoidance criteria. (→P.88)
- C** Select to block a fixed distance on the road ahead. A blocked route will be marked in the map. (→P.95)

- D** Select to display the turn list to the destination. (→P.95)
- E** Select to display the destination information. The destination can be checked and the current position can be registered. (→P.94)
- F** Select to delete a destination. (→P.95)
- ▶ When a destination and stopovers are set

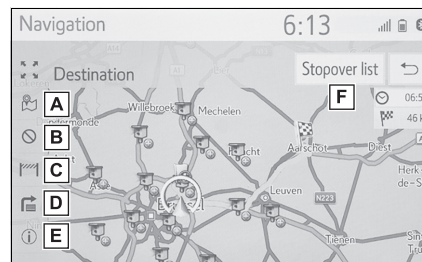

- A** Select to display the three route calculation methods. Select the desired item to adjust the route preferences. (→P.88)
- B** Select to display the avoidance criteria. Select the desired item to adjust the avoidance criteria. (→P.88)
- C** Select to block a fixed distance on the road ahead. A blocked route will be marked in the map. (→P.95)
- D** Select to display the turn list to the destination. (→P.95)

**E** Select to display the destination information. The destination can be checked and the current position can be registered. (→P.94)

**F** Select to display the destination and stopovers information. The destination and stopovers can be checked and edited. (→P.94)

**Displaying destination information**

- ▶ When a destination is set
- 1 Display the route information screen. (→P.93)
- 2 Select **i**.
- 3 Check that the destination information is displayed.

- ▶ When a destination is not set
- 1 Select **...** on the map screen. (→P.64)
- 2 Select "Info".
- 3 Check that the Current location information is displayed.

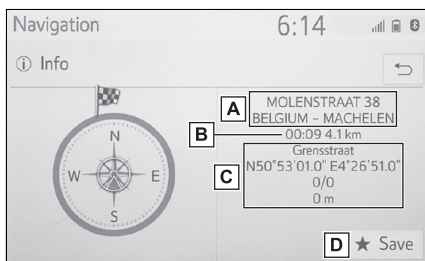

**A** Address of destination\*

**B** Arrival time, remaining time and distance to destination\*

**C** Current location information

**D** Select to register the current position in the favourites list.

\*: This is only displayed if there is an active route guidance.

**Reordering stopovers**

When more than 1 destination has been set, the arrival order of the destinations can be changed.

- 1 Display the route information screen. (→P.93)
- 2 Select "Stopover list".
- 3 Drag the desired stopover to the desired position in the list.

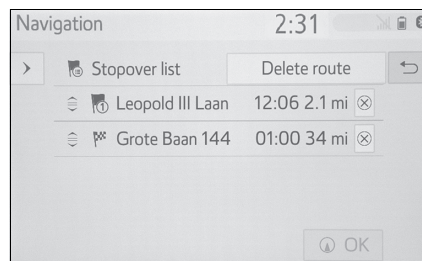

4 Select "OK".

**X**: Select to delete the stopover.

(→P.95)

"Delete route": Select to delete all destinations and stopovers on the list.

### Deleting stopovers and destination

- ▶ When a destination is set
- 1 Display the route information screen. (→P.93)
- 2 Select “Delete”.
- ▶ When a destination and stopovers are set
- 1 Display the route information screen. (→P.93)
- 2 Select “Stopover list”.
- 3 Select  of the desired stopover.
- 4 Select “Yes”.

### Blocking road segments

During the route guidance, the route can be changed to detour around a section of the route.

- 1 Display the route information screen. (→P.93)
- 2 Select .
- 3 Select the desired block distance to detour.

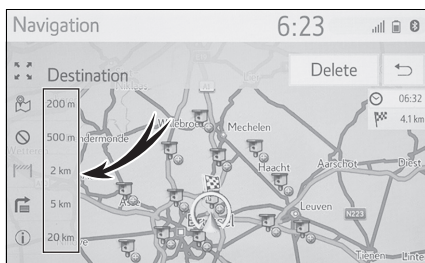

- Select “Deactivate” to cancel the blocked setting.

- The blocked route will be marked in the map.
- After the blocked route has been detoured, the blocked route feature will automatically be deactivated.

### Displaying the turn list

- 1 Display the route information screen. (→P.93)
- 2 Select .
- 3 Select the desired item to display the segment.

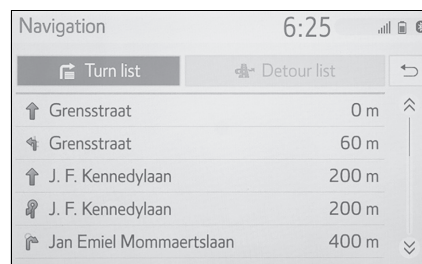

- Guidance arrow, street name, distance to the point are displayed.
- 4 Check that the detail of the segment is displayed.

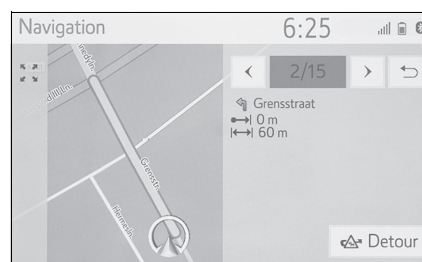

- “Detour”: Select to detour the segment. (→P.96)

### Detour setting

#### Detouring a route segment from the turn list

- 1 Display the turn list. (→P.95)
- 2 Select the desired route segment to detour.

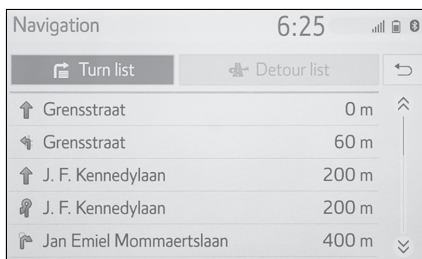

- 3 Select "Detour".

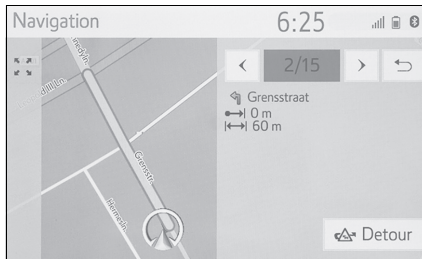

#### Canceling the detoured setting

- 1 Display the turn list. (→P.95)
- 2 Select "Detour list".

- 3 Check that the detours list is displayed. Select the desired route segment.

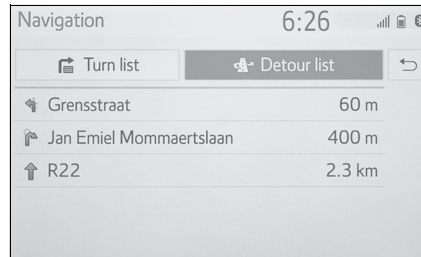

- 4 Select "Detour off" to cancel the detoured setting.

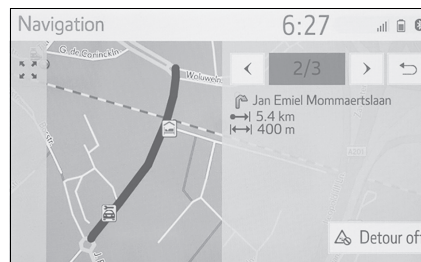

### Dynamic rerouting by the traffic messages

This feature either automatically or manually changes routes when traffic messages of the guidance route has been received.

The dynamic reroute settings can be changed. (→P.106)

#### Rerouting automatically

When traffic messages of the guidance route has been received, the route automatically changed.

- A pop-up message is displayed on the screen. The route will be recalculated automatically.

**Rerouting manually**

When traffic messages of the guidance route has been received, select manually whether or not to change routes.

- 1** A pop-up message is displayed on the screen. Select “Show detour” to display the detour route on the map.
  - Select “Ignore” to return to the previous screen.
- 2** Select “Detour”.
  - Select “Ignore” to return to the previous screen.

### Registering an entry

**Favourite points and routes on the map can be registered in the favourites list. Up to 200 entries can be registered.**

### Displaying favourites list

- 1 Display the destination menu screen. (→P.67)
- 2 Select “Favourites”.
- 3 Check that the favourites list is displayed.

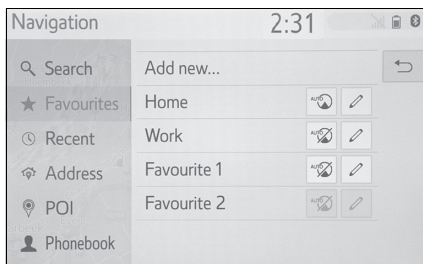

- 4 fixed favourites (home, work, and 2 other favourites) are displayed on the top of list.

### Creating a new entry

- 1 Display the favourites list. (→P.98)
- 2 Select “Add new...”.

- 3 Select the desired method to search the desired location.

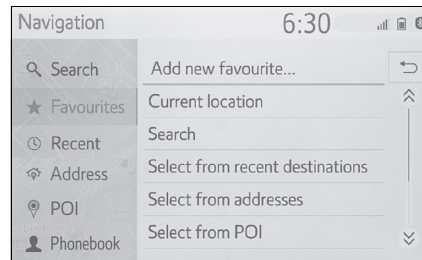

- 4 Enter the entry name and then select “OK”.
- 5 Check that the entry is registered in the favourites list.

### Registering a fixed favourite destination

4 fixed favourites (home, work, and 2 other favourites) are displayed on the top of list. Automatic navigation is available to the 4 favourite destinations.

- 1 Display the favourites list. (→P.98)
- 2 Select “Home”, “Work”, “Favourite 1” and “Favourite 2” if not registered yet.

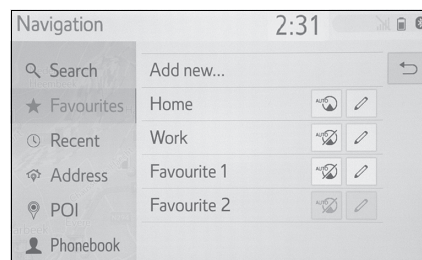

- 3 Select “Yes” if the confirmation screen appears.

- 4 Select the desired method to enter the location.

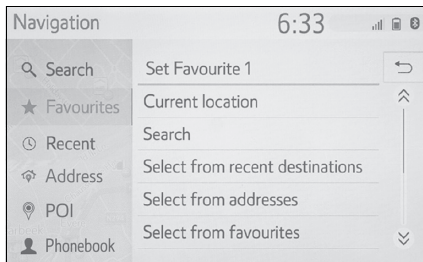

### Transferring POIs and routes via a USB memory

The POIs and routes that are registered on your Toyota portal site can be transferred via a USB memory. They will be stored in the favourites list.

- 1 Connect a device to the USB port.

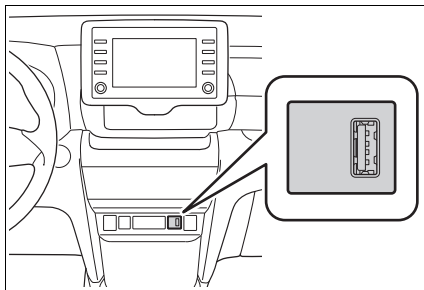

- 2 Select "Yes" when the confirmation screen appears.
- 3 Check that a progress bar is being displayed while the data loading is in progress.
  - To cancel this function, select "Cancel".
  - A confirmation screen is displayed when the operation is

complete.

- 4 Check that the entry is registered in the favourites list.

### Downloading POIs and routes via the internet

The POIs and routes that are registered on your Toyota portal site can be downloaded via the internet. They will be stored in the favourites list.

For detailed information about downloading POIs and routes: →P.233

**Editing the entry information**

**Editing the entry information**

- 1 Display the destination menu screen. (→P.67)
- 2 Select “Favourites” or “Recent”.
- 3 Select  of the desired entry.

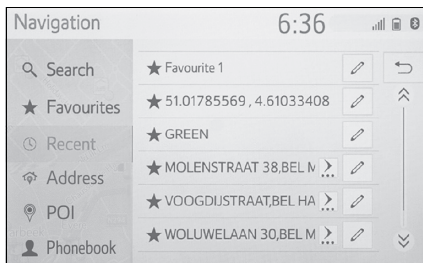

- 4 Select the desired item.

► Entries in the favourites list (Destination)

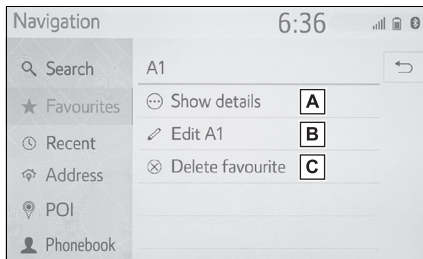

- A** Select to display detailed entry information. (→P.100)
- B** Select to change the entry name/address.
- C** Select to delete the entry.

► Entries in the favourites list (Route)

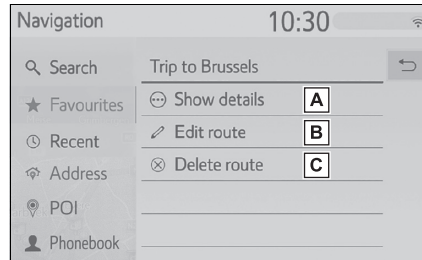

- A** Select to display detailed entry information. (→P.100)
- B** Select to edit the route. (→P.101)
- C** Select to delete the entry.

► Entries in the last destinations

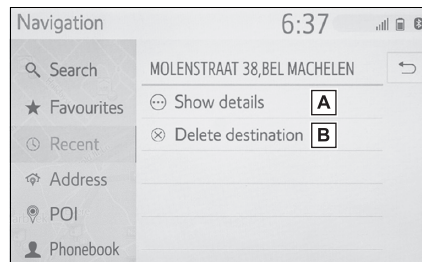

- A** Select to display detailed entry information. (→P.100)
- B** Select to delete the entry.

**Displaying details of the entry information**

- 1 Display the entry options screen. (→P.100)
- 2 Select “Show details”.

- 3 Check the details of the entry information.

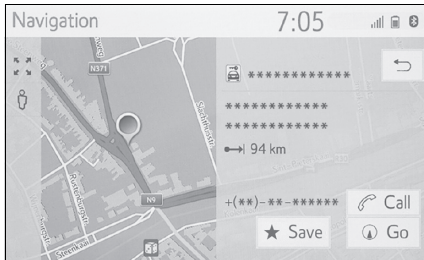

- The address will be marked on the map.

**Editing the route**

- 1 Display the entry options screen. (→P.100)
- 2 Select “Edit route”.
- 3 Select  of the desired entry.

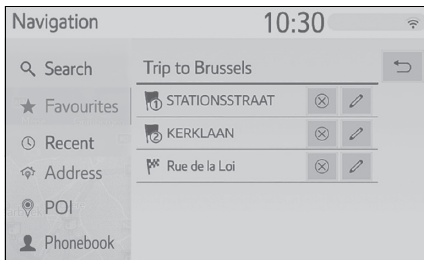

 : Select to delete destination and stopover.

- 4 Select the desired item.

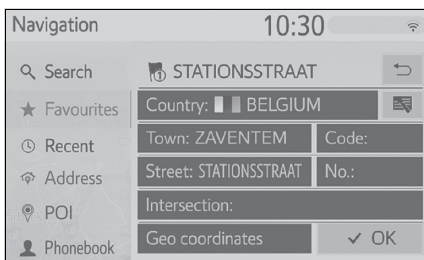

**Map settings**

**Displaying map setting screen**

1 Press the "SETUP" button.

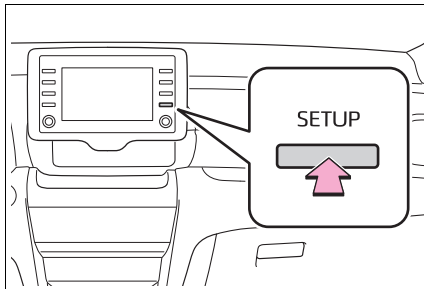

2 Select "Navigation".

3 Select "Map".

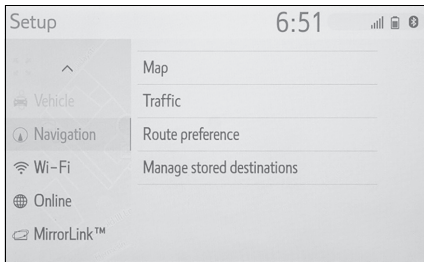

4 Select the desired item to be set.

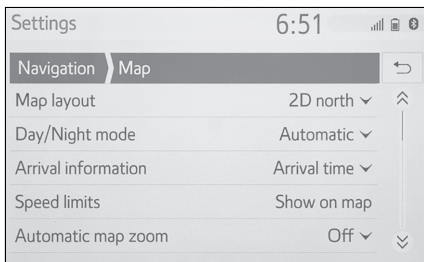

**Map setting screen**

● "Map layout"  
Select to change the map layout to 3D

heading-up, 2D heading-up or 2D north-up.

- "Day/Night mode"  
Select to change the map screen brightness. (→P.103)
- "Arrival information"  
Select to switch off, or display arrival information or remaining travel information.
- "Speed limits"  
Select to set speed limit information on/off. (→P.103)
- "Automatic map zoom"  
Select to change the zoom level that is automatically zoomed into when an area requiring caution is approached.
- "POIs on map"

Select to set displayed POI icon categories. (→P.104)

- "Show guidance arrow"  
Select to set the display of route guidance arrow on/off. (→P.90)
- "Show street name"  
Select to set the display of the name of the current street or the next street on/off. (→P.90)

● "Show 3D buildings"  
Select to set the display of 3D buildings on/off. (→P.71)

● "Show 3D landmarks"  
Select to set the display of 3D landmarks on/off. (→P.71)

● "Show signposts"  
Select to set the display of signposts on/off. (→P.90)

● "Show junction view"  
Select to set the display of the junction

view on/off. (→P.91)

● “Show lane recommendation”

Select to set the recommended lane display on/off. (→P.91)

● “Show traffic bar”

Select to set the display of traffic bar on/off. (→P.90)

● “Show traffic icons”

Select to set the display of the traffic message icons on/off. (→P.75)

● “Show speed cameras”

Select to set the display of the safety cameras icons on/off. (→P.71)

● “Use online data for speed cameras”

Select to enable using online data to show the safety camera icons.

● “Save recent route”

Select to display a trail of breadcrumbs on the map.

● “Show highway mode”

Select to set the display of the highway mode on/off. (→P.90)

● “Country information”

This function goes to another screen where it is possible to:

- Set country information screen when crossing the border on/off.
- See country information for any country in the database.

**Day/Night mode**

- 1 Display the map settings screen. (→P.102)
- 2 Select “Day/Night mode”.

**3** Select the desired item.

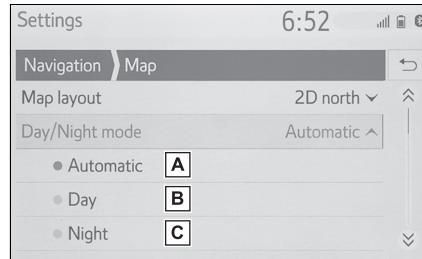

**A** Select to change the map screen to day or night mode depending on the position of the headlight switch.

**B** Select to always display the map screen in day mode.

**C** Select to always display the map screen in night mode.

**Speed limits\***

\*: If equipped

- 1 Display the map settings screen. (→P.102)
- 2 Select “Speed limits”.
- 3 Select the desired item.

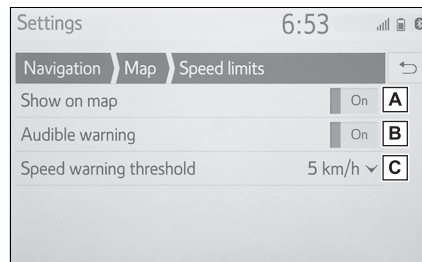

**A** Select to display the speed limits on the map.

**B** Select to receive an audible

warning, if the speed limit will be exceeded by a certain range.

- C** Select to set the speed warning threshold.

**POIs on map**

- 1 Display the map settings screen. (→P.102)
- 2 Select “POIs on map”.
- 3 Select the desired POI categories.

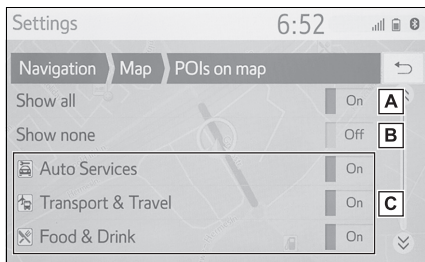

- A** Select to display all categories.
- B** Select to hide all icons.
- C** Select to display main categories and subcategories.

**Country information**

- 1 Display the map settings screen. (→P.102)
- 2 Select “Country information”.

- 3 Select the desired item.

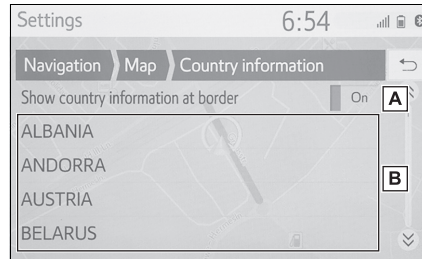

- A** Select to display the country information when the vehicle crosses a border on/off.
- B** Select to display the country information.

**Traffic message settings**

**Displaying traffic settings screen**

- 1 Press the "SETUP" button.

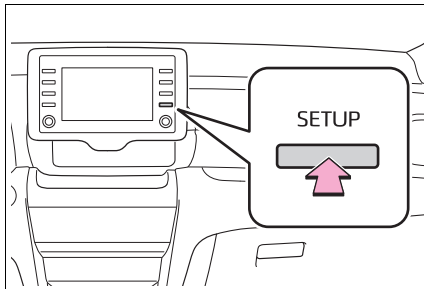

- 2 Select "Navigation".
- 3 Select "Traffic".
- 4 Select the desired item to be set.

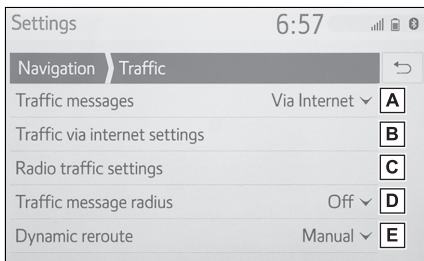

- A** Select to change the receiving method for traffic messages. (→P.105)
- B** Select to change settings for traffic over internet. (→P.105)
- C** Select to set the TMC (Traffic message channel) setup.
- D** Select to set the radius for displaying traffic messages.

(→P.106)

- E** Select to set the dynamic reroute method. (→P.106)

**Receiving method for traffic messages**

- 1 Display the traffic settings screen. (→P.105)
- 2 Select "Traffic messages".
- 3 Select the desired item.

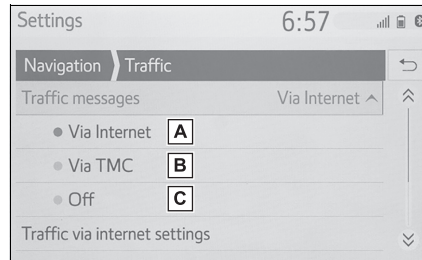

- A** Select to receive traffic messages via the internet.
- B** Select to receive traffic messages via the TMC (Traffic message channel).
- C** Select to not receive the traffic messages.

**Receiving setting for traffic messages via internet**

- 1 Display the traffic settings screen. (→P.105)
- 2 Select "Traffic via internet settings".

3 Select the desired item.

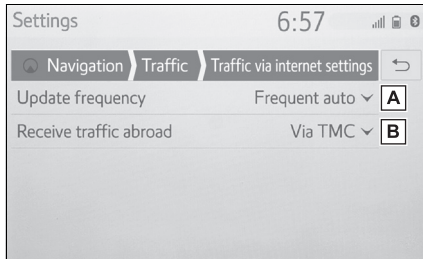

- A** Select to set the refresh frequencies for the domestic traffic messages via the internet.
- B** Select to change the receiving method for traffic messages when the car is outside of its home country.

**Receiving setting for traffic messages via TMC**

- 1 Display the traffic settings screen. (→P.105)
- 2 Select “Radio traffic settings”.
- 3 Select the desired item.

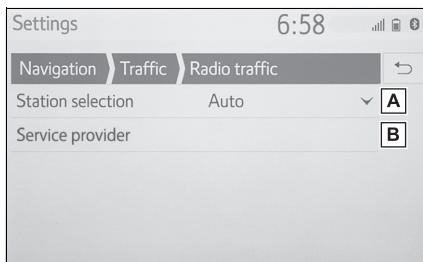

- A** Select to change the receiving settings of FM radio to automatic or manual.
- B** Radio station allows the user to

manually select the preferred TMC station from a list of available stations.

**Setting radius filter**

- 1 Display the traffic settings screen. (→P.105)
- 2 Select “Traffic message radius”.
- 3 Select desired radius.

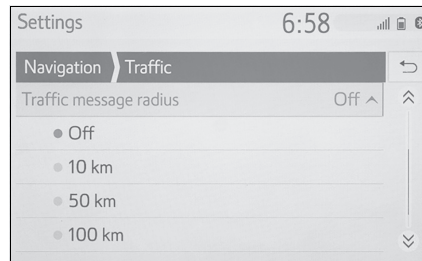

- This setting is for route calculation. Only traffic messages within the radius are taken into account during calculation.

**Setting dynamic reroute method**

- 1 Display the traffic settings screen. (→P.105)
- 2 Select “Dynamic reroute”.
- 3 Select the desired item.

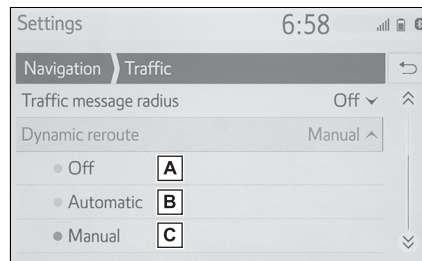

- A** Select to turn off the rerouting when traffic messages on the guidance route are received.
- B** Select to reroute automatically. The route automatically changes when traffic messages on the guidance route are received.
- C** Select to reroute manually. When traffic messages on the guidance route are received, select manually whether or not to change routes.

**Route preferences settings**

**Displaying route preferences screen**

- 1** Press the "SETUP" button.

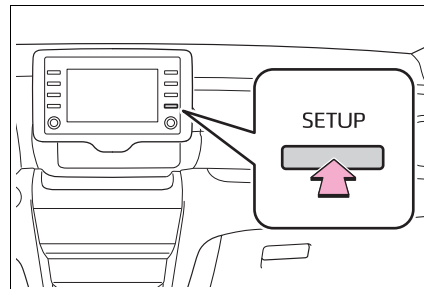

- 2** Select "Navigation".
- 3** Select "Route preference".
- 4** Select the desired item to be set.

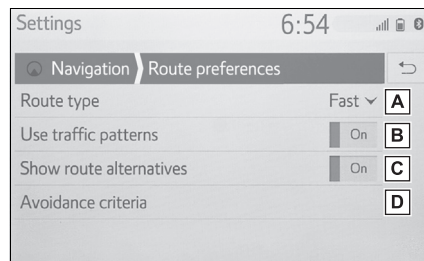

- A** Select to change the recommended route type to fastest route, shortest route or ecological route.
- B** Select to use historical traffic information in the route calculation.
- C** Select to display the 3 routes (fastest, shortest and ecological)

**3**  
Navigation system

on the map after route calculation. (→P.88)

- D** Select to set the default avoidance criteria for the route calculation. (→P.108)

**Setting the avoidance criteria for the route calculation**

- 1 Display the navigation settings screen. (→P.107)
- 2 Select “Avoidance criteria”.
- 3 Select the desired items to avoid.

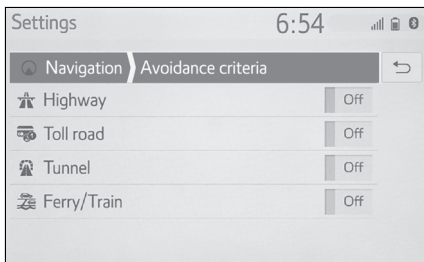

**Displaying Manage stored destinations screen**

- 1 Press the “SETUP” button.
- 2 Select “Navigation”.
- 3 Select “Manage stored destinations”.

- 4 Select the desired item.

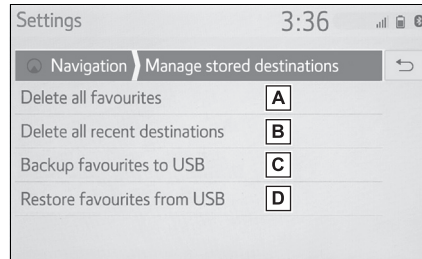

- A** Select to delete all favourites.
- B** Select to delete all recent destinations.
- C** The navigation favourites will be sent to the connected USB device.
- D** The backup of the favourites on the USB device will be loaded into the list of favourites on the navigation system.

### GPS (Global Positioning System)

**This navigation system calculates the current position using satellite signals, various vehicle signals, map data, etc. However, an accurate position may not be shown depending on satellite conditions, road configuration, vehicle condition or other circumstances.**

### Limitations of the navigation system

The Global Positioning System (GPS) developed and operated by the U.S. Department of Defense provides an accurate current position, normally using 4 or more satellites, and in some case 3 satellites. The GPS system has a certain level of inaccuracy. While the navigation system compensates for this most of the time, occasional positioning errors of up to 100 m can and should be expected. Generally, position errors will be corrected within a few seconds.

The GPS signal may be physically obstructed, leading to inaccurate vehicle position on the map screen. Tunnels, tall buildings, trucks, or even the placement of objects on the instrument panel may obstruct the GPS signals.

The GPS satellites may not send

signals due to repairs or improvements being made to them.

Even when the navigation system is receiving clear GPS signals, the vehicle position may not be shown accurately or inappropriate route guidance may occur in some cases.

#### NOTICE

- The installation of window tinting may obstruct the GPS signals. Most window tinting contains some metallic content that will interfere with GPS signal reception of the antenna in the instrument panel. We advise against the use of window tinting on vehicles equipped with navigation systems.
- Accurate current position may not be shown in the following cases:
  - When driving on a small angled Y-shaped road.
  - When driving on a winding road.
  - When driving on a slippery road such as in sand, gravel, snow, etc.
  - When driving on a long straight road.
  - When motorway and surface streets run in parallel.
  - After moving by ferry or vehicle carrier.
  - When a long route is searched during high speed driving.
  - When driving without setting the current position calibration correctly.
  - After repeating a change of direction by going forward and backward, or turning on a turntable in a parking lot.
  - When leaving a covered parking lot or parking garage.
  - When a roof carrier is installed.

- When driving with tyre chains installed.
  - When the tyres are worn.
  - After replacing a tyre or tyres.
  - When using tyres that are smaller or larger than the factory specifications.
  - When the tyre pressure in any of the 4 tyres is not correct.
  - Inappropriate route guidance may occur in the following cases:
    - When turning at an intersection off the designated route guidance.
    - If you set more than 1 destination but skip any of them, auto reroute will display a route returning to the destination on the previous route.
    - When turning at an intersection for which there is no route guidance.
    - When passing through an intersection for which there is no route guidance.
    - During auto reroute, the route guidance may not be available for the next turn to the right or left.
    - During high speed driving, it may take a long time for auto reroute to operate. In auto reroute, a detour route may be shown.
    - After auto reroute, the route may not be changed.
    - If an unnecessary U-turn is shown or announced.
    - If a location has multiple names and the system announces 1 or more of them.
    - When a route cannot be searched.
    - If the route to your destination includes gravel, unpaved roads or alleys, the route guidance may not be shown.
    - Your destination point might be shown on the opposite side of the street.
  - When a portion of the route has regulations prohibiting the entry of the vehicle that vary by time or season or other reasons.
  - The road and map data stored in the navigation system may not be complete or may not be the latest version.
- 
- This navigation system uses tyre turning data and is designed to work with factory-specified tyres for the vehicle. Installing tyres that are larger or smaller than the originally equipped diameter may cause inaccurate display of the current position. The tyre pressure also affects the diameter of the tyres, so make sure that the tyre pressure of all 4 tyres is correct.

**Navigation database updates**

Navigation database which contains system software, map data, Gracenote database, etc., can be updated using a USB memory.

For details, contact Toyota dealer or refer to Toyota portal site ([www.my.toyota.eu](http://www.my.toyota.eu)).

**Updating navigation database**

- 1 Connect a device to the USB port.

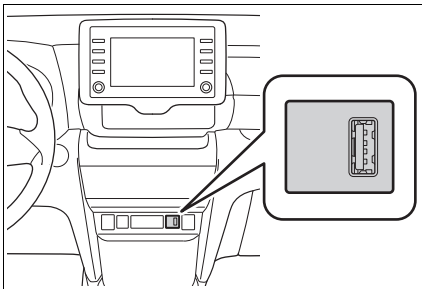

- 2 Plug in the USB device containing the new navigation database files.
- 3 Select "Yes" to update.
- 4 Enter activation code if required.
  - If the activation code is invalid, the navigation database will not be updated.
- 5 Make sure the engine is running <the hybrid system operating>

and select "Confirm" to continue with the update.

- You will see an update progress screen followed by a confirmation that the database has updated successfully.
- 6 Remove the USB device when prompted. This restarts the navigation system and completes the update process.

- Updating may not complete correctly in the following cases:
  - If the navigation system is turned off before updating is complete
  - If the USB device is removed before updating is complete
- The amount of time required to complete the update process depends on the size of the data.



**Audio/visual system****4**

- 4-1. Basic operation**
  - Quick reference .....114
  - Some basics .....115
- 4-2. Radio operation**
  - AM/FM/DAB radio.....120
- 4-3. Media operation**
  - USB memory .....125
  - iPod/iPhone (Apple CarPlay)  
.....127
  - Android Auto .....130
  - Bluetooth® audio.....131
  - Miracast® .....134
- 4-4. Audio/visual remote controls**
  - Steering switches .....137
- 4-5. Setup**
  - Audio settings .....138
- 4-6. Tips for operating the audio/visual system**
  - Operating information .....139

For vehicles sold outside Europe, some of the functions cannot be operated while driving.

## Quick reference

### Functional overview

The audio control screen can be reached by the following methods:

- ▶ From the “AUDIO” button
  - 1 Press the “AUDIO” button.
- ▶ From the “MENU” button
  - 1 Press the “MENU” button, then select “Audio”.

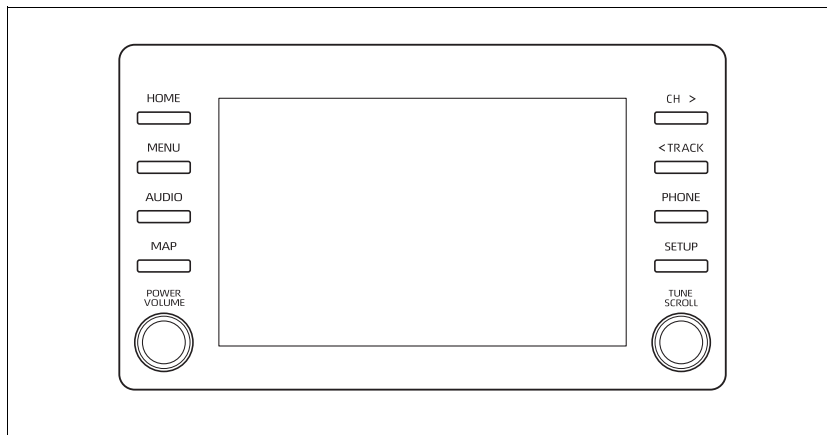

- Using the radio (→P.120)
- Playing a USB memory (→P.125)
- Playing an iPod/iPhone (Apple CarPlay\*) (→P.127)
- Using the Android Auto\* (→P.130)
- Playing a Bluetooth® device (→P.131)
- Using the Miracast® (→P.134)
- Using the steering wheel audio switches (→P.137)
- Audio system settings (→P.138)

\* : This function is not made available in some countries or areas.

**Some basics**

This section describes some of the basic features of the audio/visual system. Some information may not pertain to your system.

Your audio/visual system works when the engine switch <power switch> is in ACC or ON.

 NOTICE

- To prevent the 12-volt battery from being discharged, do not leave the audio/visual system on longer than necessary when the engine is not running <the hybrid system is not operating>.

**Turning the system on and off**

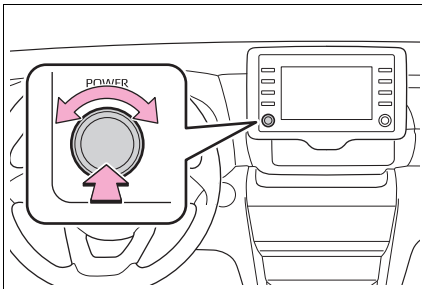

“POWER VOLUME” knob: Press to turn the audio/visual system on and off. The system turns on in the last mode used. Turn this knob to adjust the volume.

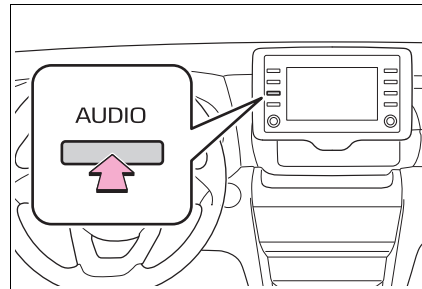

**Selecting an audio source**

- 1 Press the “AUDIO” button.

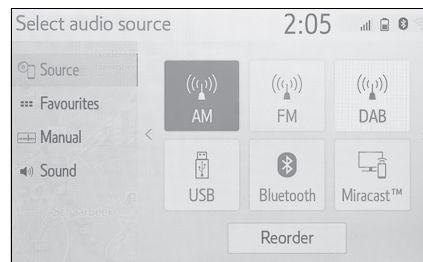

- 2 Select “Source” or press “AUDIO” button again.
- 3 Select the desired source.



- Dimmed screen buttons cannot be operated.
- When there are two pages, select  or  to change the page.
- When an Apple CarPlay/Android Auto connection is established, some system functions, such as the following, will be replaced by similar Apple CarPlay/Android Auto function or will become unavailable:
  - iPod (Audio Playback)
  - USB audio/USB video
  - Bluetooth® audio

**Reordering the audio source**

- 1 Display the audio source selection screen. (→P.115)
- 2 Select “Reorder”.
- 3 Select the desired audio source then < or > to reorder.

**USB port**

- 1 Connect a device to the USB port.

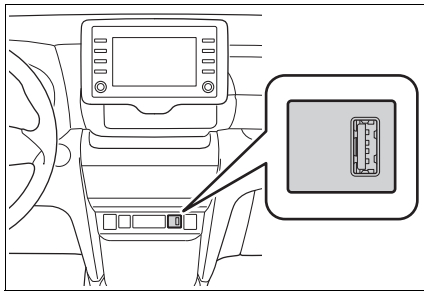

- Turn on the power of the device if it is not turned on.
- If a USB hub is plugged-in, two devices can be connected at a time.
- Even if a USB hub is used to connect more than two USB devices, only the first two connected devices will be recognized.
- If a USB hub that has more than two ports is connected to the USB port, devices connected to the USB hub may not charge or be operable, as the supply of current may be insufficient.

**Sound settings**

- 1 Display the audio control screen. (→P.114)

- 2 Select “Sound”.
- 3 Select the desired item to be set.

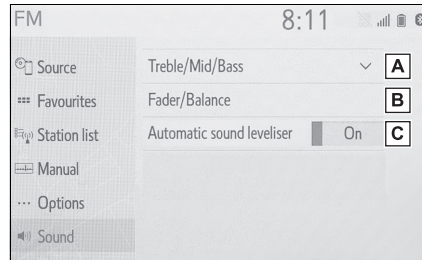

- A** Select to set the treble/mid/bass. (→P.116)
- B** Select to set the fader/balance. (→P.117)
- C** Select to set the automatic sound leveliser. (→P.117)

**Treble/Mid/Bass**

How good an audio program sounds is largely determined by the mix of the treble, mid and bass levels. In fact, different kinds of music and vocal programs usually sound better with different mixes of treble, mid and bass.

- 1 Select “Treble/Mid/Bass”.
- 2 Select the desired screen button.

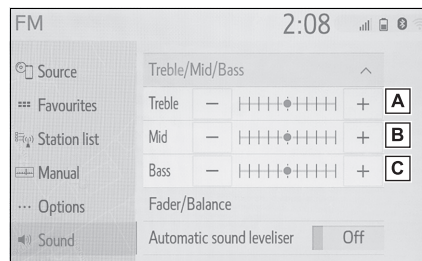

- A** Select “+” or “-” to adjust high-pitched tones.
- B** Select “+” or “-” to adjust mid-pitched tones.
- C** Select “+” or “-” to adjust low-pitched tones.

#### ■ Fader/Balance

A good balance of the left and right stereo channels and of the front and rear sound levels is also important.

Keep in mind that when listening to a stereo recording or broadcast, changing the right/left balance will increase the volume of 1 group of sounds while decreasing the volume of another.

- 1 Select “Fader/Balance”.
- 2 Select the desired screen button.

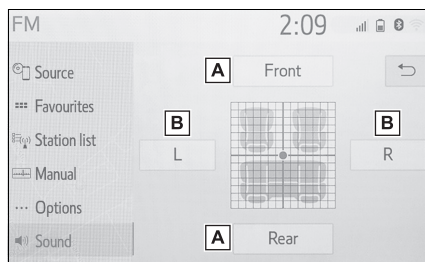

- A** Select to adjust the sound balance between the front and rear speakers.
- B** Select to adjust the sound balance between the left and right speakers.

#### ■ Automatic sound leveliser (ASL)

The system adjusts to the optimum volume and tone quality according to vehicle speed to compensate for increased road noise, wind noise, or other noises while driving.

##### ► Type A

- 1 Select “Automatic sound leveliser”.
- 2 Select “High”, “Mid”, “Low” or “Off”.

##### ► Type B

- 1 Select “Automatic sound leveliser”.
- 2 Select to set the automatic sound leveliser on/off.

#### Audio screen adjustment

##### ■ Screen format settings

The screen adjustment can be selected for USB video and Miracast®.

##### ► From the audio settings screen

- 1 Press the “SETUP” button.
- 2 Select “Audio”.
- 3 Select “Common”.
- 4 Select “Screen format”.

- 5 Select the desired item to be adjusted.

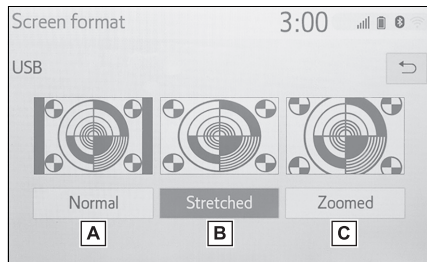

- A** Select to display a 4 : 3 screen, with either side in black.
- B** Select to enlarge the image horizontally and vertically to full screen.
- C** Select to enlarge the image by the same ratio horizontally and vertically.\*

\*: USB video only

- ▶ From the Miracast® control screen

- 1 Display the Miracast® control screen. (→P.134)
- 2 Select "Wide".
- 3 Follow the steps in "From the audio settings screen" from step 5. (→P.117)

#### ■ Colour, tone, contrast and brightness adjustment

The colour, tone, contrast and brightness of the screen can be adjusted.

- ▶ From the audio settings screen

- 1 Press the "SETUP" button.

- 2 Select "Audio".
- 3 Select "Common".
- 4 Select "Display".
- 5 Select the desired item to be adjusted.

- "Colour"

"R": Select to strengthen the red colour of the screen.

"G": Select to strengthen the green colour of the screen.

- "Tone"

"+": Select to strengthen the tone of the screen.

"-": Select to weaken the tone of the screen.

- "Contrast"

"+": Select to strengthen the contrast of the screen.

"-": Select to weaken the contrast of the screen.

- "Brightness"

"+": Select to brighten the screen.

"-": Select to darken the screen.

---

● Depending on the audio source, some functions may not be available.

- ▶ From the Miracast® control screen

- 1 Display the Miracast® control screen. (→P.134)
- 2 Select "Display".
- 3 Follow the steps in "From the audio settings screen" from step 5. (→P.118)

### Speech command system

- 1 Press this switch to operate the speech command system.

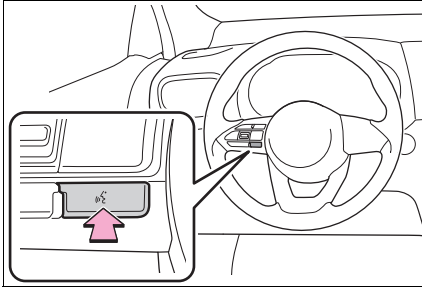

- The speech command system and its list of commands can be operated. (→P.148)

### AM/FM/DAB\* radio

\*: If equipped

#### Overview

The radio control screen can be reached by the following methods:  
→P.115

#### Control screen

##### ▶ AM/FM

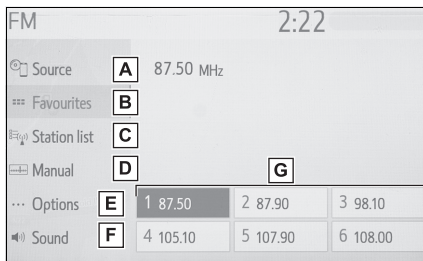

- A** Select to display the audio source selection screen.
- B** Select to display the favourites screen. (→P.121)
- C** Select to display a list of receivable stations.\*
- D** Select to display the manual tuning screen. (→P.122)
- E** Select to display the radio options screen.\* (→P.122)
- F** Select to display the sound setting screen. (→P.116)
- G** Select to tune to preset stations.

(→P.121)

\*: FM only

##### ▶ DAB

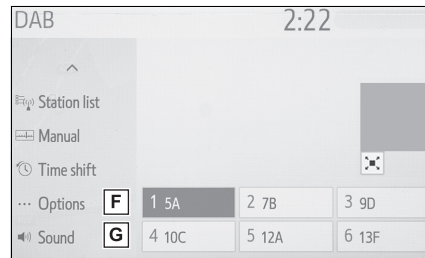
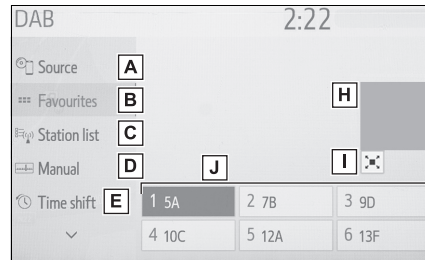

- A** Select to display the audio source selection screen.
- B** Select to display the favourites screen. (→P.121)
- C** Select to display a list of receivable service/station.
- D** Select to display the manual tuning screen. (→P.122)
- E** Select to display the time shift control screen. (→P.123)
- F** Select to display the radio options screen. (→P.122)
- G** Select to display the sound setting screen. (→P.116)
- H** Displays the slideshow images.

The slideshow is available depending on the service.

- I** Select to switch to the expanded slideshow. To return to the previous screen, touch the button again.
- J** Select to tune to preset service/station. (→P.121)

### Control panel

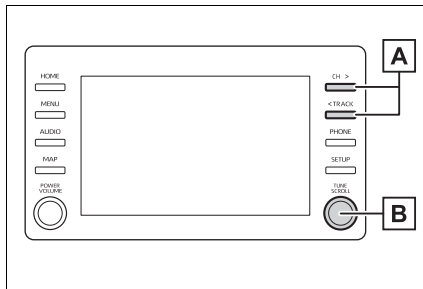

- A** AM/FM:
  - Favourites screen: Press to select preset stations.
  - Station list screen: Press to move up/down the station.
  - Manual screen: Press to seek for stations. Press and hold for continuous seek.
- DAB:
  - Favourites screen: Press to select preset services/stations.
  - Service/station list screen: Press to move up/down the service/station.
  - Manual screen: Press to seek for service/station. Press and

hold for continuous seek.

- B** AM/FM:
  - Favourites screen: Turn to select preset stations.
  - Station list screen: Turn to move up/down the station.
  - Manual screen: Turn to seek for frequencies.
- DAB:
  - Favourites screen: Turn to select preset services/stations.
  - Service/station list screen: Turn to move up/down the service/station.
  - Manual screen: Turn to seek for service.
  - DAB time shift screen: Turn to jump forward/backwards.

- The radio automatically changes to stereo reception when a stereo broadcast is received.
- If the signal becomes weak, the radio reduces the amount of channel separation to prevent the weak signal from creating noise. If the signal becomes extremely weak, the radio switches from stereo to mono reception.

### Presetting a station

Up to 6 preset stations/services can be registered in AM mode, FM mode and DAB mode.

- 1 Tune in the desired station.

- 2 Select one of the screen buttons (1-6) and hold it until a beep is heard.



- The station's frequency will be displayed in the screen button.
- To change the preset stations/services to a different one, follow the same procedure.

### Manual tuning

► AM/FM

- 1 Select "Manual".
- 2 Tune the desired station.

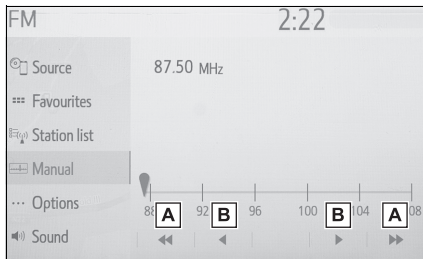

- A** Select to seek up/down for a station.
  - B** Select to step up/down frequencies.
- DAB
- 1 Select "Manual".

- 2 Tune the desired DAB ensemble or service.

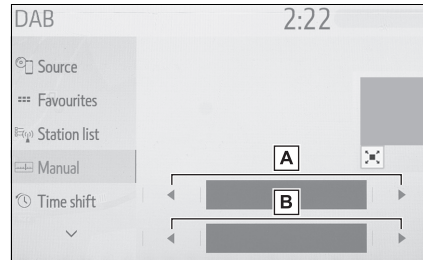

- A** Select to set the desired ensemble.
- B** Select to set the desired service/station.

### Radio options

- 1 Select "Options".
  - 2 Select the desired item.
- FM

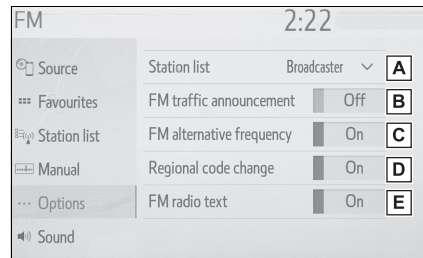

- A** Select to set the listing order of the station list between "Broadcaster" and "Alphabetical".
- B** Select to set the FM traffic announcement on/off. (→P.123)
- C** Select to set the FM alternative frequency function on/off. (→P.123)

**D** Select to switch to a broadcasting station within the same local program network.

**E** Select to set the FM radio text feature on/off.

► DAB

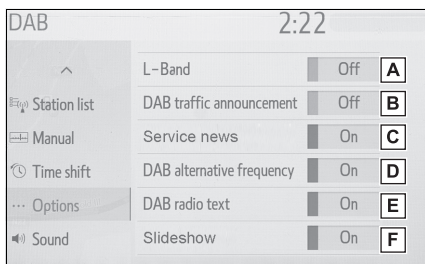

**A** Select on/off to set L-band in the tune range. When “Off” is selected, the physical channel range for tuning operations is limited to Band III, excluding for preset operations. When “On” is selected, the physical channel range for tuning operations includes Band III and L-band.

**B** Select to set the DAB traffic announcement on/off. (→P.123)

**C** Select to set the Service news announcements on/off. (→P.124)

**D** Select to set the DAB alternative frequency function on/off. (→P.123)

**E** Select on/off to set the DAB text feature.

**F** Select to set the slideshow feature on/off.

● Radio settings can be set on the audio settings screen. (→P.138)

**Time shift operation (DAB)**

The service you are currently listening to can be re-listened to at any time.

- 1 Select “Time shift”.
- 2 Select the desired operation button.

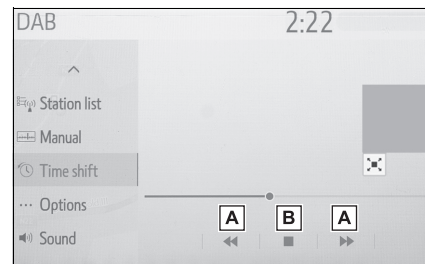

**A** Select to jump forward/backward by 10 seconds. Select and hold to fast forward/backward.

**B** Returns to the live radio broadcast.

● The times at which playback is possible depend on the bit rate of the service to be recorded, the amount of DAB unit memory, and the time at which reception of the broadcast began.

**RDS (Radio data system)**

This feature allows your radio to receive station and programmed information from radio stations

which broadcast this information. Depending on the availability of RDS infrastructure, the service may not function properly.

**AF (Alternative frequency) function (FM/DAB)**

A station providing good reception is automatically selected if current reception worsens.

**TA (Traffic announcement) function (FM/DAB)**

The tuner will automatically seek a station that regularly broadcasts traffic information and the station broadcasts when the traffic information program starts.

- 1 A pop-up message is displayed on the screen when the radio seeks out a TP station.
- 2 Select "Continue".

- When traffic announcement is set to on (→P.122), the radio will begin seeking a TP station.
- When the program ends, the initial operation resumes.

**Traffic announcement volume function**

The volume level when receiving the traffic announcement is memorized.

**Service news announcements (DAB)**

When there is a DAB announce-

ment broadcast (such as news, weather information, alerts, or warnings), it will interrupt the current program and broadcast the DAB announcement.

- When "Service news" is set to on (→P.122), the system will receive the DAB announcement broadcast.
- When the announcement ends, system resumes the previous program.
- Alarm announcements are broadcast even if the settings is off.

**USB memory**

**Overview**

The USB memory operation screen can be reached by the following methods: →P.115

- Connecting a USB memory (→P.116)
- When an Apple CarPlay/Android Auto connection is established, this function will be unavailable.

**Control screen**

▶ USB audio

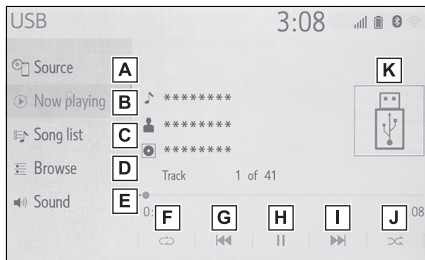

- A** Select to display the audio source selection screen.
- B** Select to return to the top screen.
- C** Select to display a song list screen.
- D** Select to display the play mode selection screen.
- E** Select to display the sound setting screen. (→P.116)
- F** Select to set repeat playback.

(→P.126)

- G** Select to change the file/track. Select and hold to fast rewind.
- H** Select to play/pause.
- I** Select to change the file/track. Select and hold to fast forward.
- J** Select to set random playback. (→P.126)

**K** Displays cover art

▶ USB video

- 1 Select “Browse”.
- 2 Select “Videos”.
- 3 Select the desired folder and file.

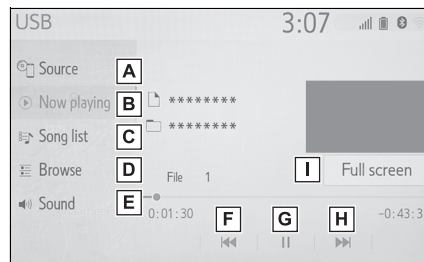

- A** Select to display the audio source selection screen.
- B** Select to return to the top screen.
- C** Select to display a song list screen.
- D** Select to display the play mode selection screen.
- E** Select to display the sound setting screen. (→P.116)

4 Audio/visual system

- F** Select to change the file. Select and hold to fast rewind.
- G** Select to play/pause.
- H** Select to change the file. Select and hold to fast forward.
- I** Select to display a full screen image.

**Control panel**

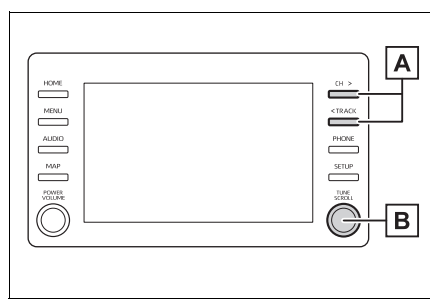

- A** Press to change the file/track. Press and hold to fast forward/rewind.
- B** Turn to change the file/track. Turn to move up/down the list. Also, the knob can be used to enter selections on the list screens by pressing it.

- While the vehicle is being driven, this function can only output sound.
- If tag information exists, the file/folder names will be changed to track/album names.

**Repeating**

The file/track or folder/album cur-

rently being listened to can be repeated.

- 1 Select

- Each time is selected, the mode changes as follows:
  - ▶ When random playback is off
    - file/track repeat → folder/album repeat → off
  - ▶ When random playback is on
    - file/track repeat → off

**Random order**

Files/tracks or folders/albums can be automatically and randomly selected.

- 1 Select

- Each time is selected, the mode changes as follows:
  - random (1 folder/album random) → folder/album random (all folder/album random) → off

**WARNING**

- Do not operate the player's controls or connect the USB memory while driving.

**NOTICE**

- Do not leave your portable player in the vehicle. In particular, high temperatures inside the vehicle may damage the portable player.
- Do not push down on or apply unnecessary pressure to the portable player while it is connected as this may damage the portable player or its terminal.

 **NOTICE**  
 ● Do not insert foreign objects into the port as this may damage the portable player or its terminal.

**iPod/iPhone (Apple CarPlay<sup>\*</sup>)**

\*: This function is not made available in some countries or areas

**Overview**

The iPod/iPhone operation screen can be reached by the following methods: →P.115

- Connecting an iPod/iPhone (→P.116)
- When an Android Auto connection is established, this function will be unavailable.

**Control screen**

- ▶ An Apple CarPlay connection is not established

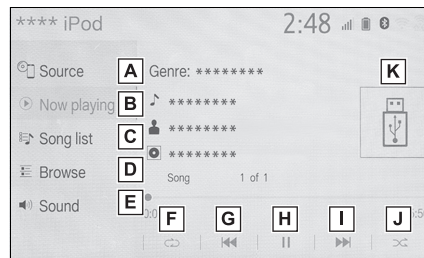

- ▶ An Apple CarPlay connection is established

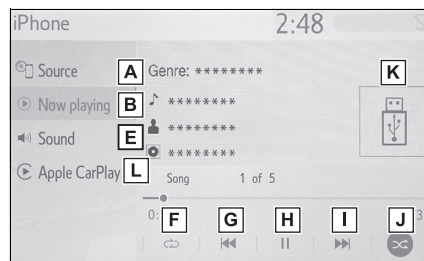

4  
 Audio/visual system

- A** Select to display the audio source selection screen.
- B** Select to return to the top screen.
- C** Select to display a song list screen.
- D** Select to display the play mode selection screen.
- E** Select to display the sound setting screen. (→P.116)
- F** Select to set repeat playback. (→P.129)
- G** Select to change the track. Select and hold to fast rewind.
- H** Select to play/pause.
- I** Select to change the track. Select and hold to fast forward.
- J** Select to set random playback. (→P.129)
- K** Displays cover art
- L** Select to display the audio control screen of Apple CarPlay.

### Control panel

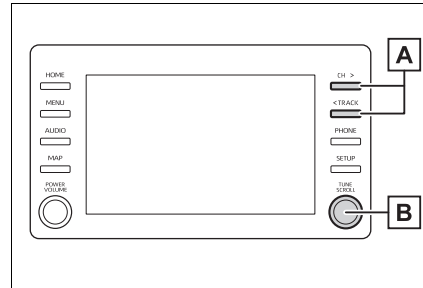

- A** Press to change the track. Press and hold to fast forward/rewind.
- B** Turn to move up/down the list. Also, the knob can be used to enter selections on the list screens by pressing it.

- Some functions may not be available depending on the type of model.
- When an iPod/iPhone is connected using a genuine iPod/iPhone cable, the iPod/iPhone starts charging its battery.
- Depending on the iPod/iPhone, the video sound may not be able to be heard.
- Depending on the iPod/iPhone and the songs in the iPod/iPhone, cover art may be displayed. This function can be changed to “On” or “Off”. (→P.138) It may take time to display cover art, and the iPod/iPhone may not be operated while the cover art display is in process.
- When an iPod/iPhone is connected and the audio source is changed to iPod/iPhone mode, the iPod/iPhone will resume playing from the same point it was last used.
- Depending on the iPod/iPhone that is connected to the system, certain functions may not be available.

- Tracks selected by operating a connected iPod/iPhone may not be recognized or displayed properly.
- The system may not function properly if a conversion adapter is used to connect a device.

### Repeating

The track currently being listened to can be repeated.

- 1 Select .

- Each time  is selected, the mode changes as follows:
  - ▶ When shuffle is off (iPhone 5 or later)
    - track repeat → album repeat → off
  - ▶ When shuffle is off (iPhone 4s or earlier)
    - track repeat → off
  - ▶ When shuffle is on
    - track repeat → off

### Random order

Tracks or albums can be automatically and randomly selected.

- 1 Select .

- Each time  is selected, the mode changes as follows:
  - shuffle (1 album shuffle) → album shuffle (all album shuffle) → off



### WARNING

- Do not operate the player's controls or connect the iPod while driving.



### NOTICE

- Do not leave your portable player in the vehicle. In particular, high temperatures inside the vehicle may damage the portable player.
- Do not push down on or apply unnecessary pressure to the portable player while it is connected as this may damage the portable player or its terminal.
- Do not insert foreign objects into the port as this may damage the portable player or its terminal.

### Android Auto\*

\*: This function is not made available in some countries or areas.

#### Overview

The Android Auto operation screen can be reached by the following methods: →P.115

- Connecting an Android Auto device (→P.116)
- When an Apple CarPlay connection is established, this function will be unavailable.

#### Control screen

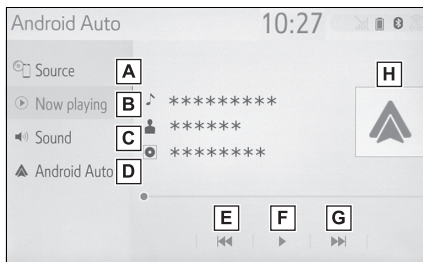

- A** Select to display the audio source selection screen.
- B** Select to return to the top screen.
- C** Select to display the sound setting screen. (→P.116)
- D** Select to display the audio control screen of Android Auto.
- E** Select to change the track.
- F** Select to play/pause.

**G** Select to change the track.

**H** Displays cover art

#### Control panel

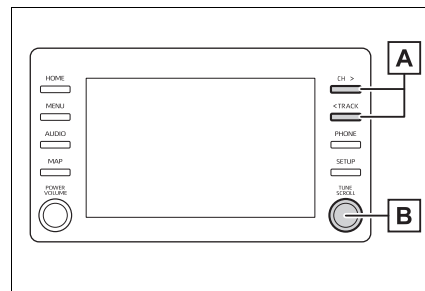

**A** Press to change the track.

**B** Turn to change the track.

#### WARNING

- Do not connect smartphone or operate the controls while driving.

#### NOTICE

- Do not leave your smartphone in the vehicle. In particular, high temperatures inside the vehicle may damage the smartphone.
- Do not push down on or apply unnecessary pressure to the smartphone while it is connected as this may damage the smartphone or its terminal.
- Do not insert foreign objects into the port as this may damage the smartphone or its terminal.

## Bluetooth® audio

The Bluetooth® audio system enables users to enjoy listening to music that is played on a portable player on the vehicle speakers via wireless communication.

This audio/visual system supports Bluetooth®, a wireless data system capable of playing portable audio music without cables. If your device does not support Bluetooth®, the Bluetooth® audio system will not function.

### Overview

The Bluetooth® audio operation screen can be reached by the following methods: →P.115

- Connecting a Bluetooth® audio device (→P.133)
- Depending on the type of portable player connected, some functions may not be available and/or the screen may look differently than shown in this manual.
- When an Apple CarPlay/Android Auto connection is established, Bluetooth® audio will be suspended and become unavailable.

### Control screen

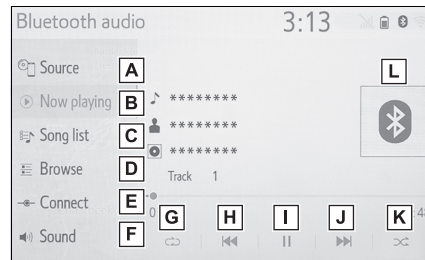

- A** Select to display the audio source selection screen.
- B** Select to return to the top screen.
- C** Select to display a song list screen.
- D** Select to display the play mode selection screen.
- E** Select to display the portable device connection screen. (→P.133)
- F** Select to display the sound setting screen. (→P.116)
- G** Select to set repeat playback. (→P.132)
- H** Select to change the track. Select and hold to fast rewind.
- I** Select to play/pause.
- J** Select to change the track. Select and hold to fast forward.
- K** Select to set random playback. (→P.132)

4

Audio/visual system

**L** Displays cover art

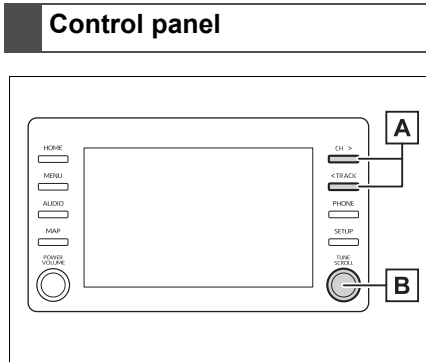

**A** Press to change the track. Press and hold to fast forward/rewind.

**B** Turn to move up/down the list. Also, the knob can be used to enter selections on the list screens by pressing it.

### Repeating

The track or album currently being listened to can be repeated.



1 Select .

- Each time  is selected, the mode changes as follows:
  - ▶ When random playback is off
    - repeat all → track repeat → album repeat → off
  - ▶ When random playback is on
    - repeat all → track repeat → off

### Random order

Tracks or albums can be automatically and randomly selected.

1 Select .

- Each time  is selected, the mode changes as follows:
  - random (1 album random) → album random (all album random) → off
- Depending on the Bluetooth® device that is connected to the system, the music may start playing when selecting  while it is paused. Conversely, the music may pause when selecting  while it is playing.
- In the following conditions, the system may not function:
  - The Bluetooth® device is turned off.
  - The Bluetooth® device is not connected.
  - The Bluetooth® device has a low battery.
- When using the Bluetooth® audio and Wi-Fi® functions at the same time, the following problems may occur:
  - It may take longer than normal to connect to the Bluetooth® device.
  - The sound may cut out.
- It may take time to connect the phone when Bluetooth® audio is being played.
- For operating the portable player, see the instruction manual that comes with it.
- If the Bluetooth® device is disconnected due to poor reception from the Bluetooth® network when the engine switch <power switch> is in ACC or ON, the system will automatically reconnect to the portable player.
- If the Bluetooth® device is disconnected on purpose, such as it was turned off, this does not happen. Reconnect the portable player manually.

- Bluetooth® device information is registered when the Bluetooth® device is connected to the Bluetooth® audio system. When selling or disposing of the vehicle, remove the Bluetooth® audio information from the system. (→P.59)
- In some situations, sound output via the Bluetooth® audio system may be out of sync with the connected device or output intermittently.

#### WARNING

- Do not operate the player's controls or connect to the Bluetooth® audio system while driving.
- Your audio unit is fitted with Bluetooth® antennas. People with implantable cardiac pacemakers, cardiac resynchronization therapy-pacemakers or implantable cardioverter defibrillators should maintain a reasonable distance between themselves and the Bluetooth® antennas. The radio waves may affect the operation of such devices.
- Before using Bluetooth® devices, users of any electrical medical device other than implantable cardiac pacemakers, cardiac resynchronization therapy-pacemakers or implantable cardioverter defibrillators should consult the manufacturer of the device for information about its operation under the influence of radio waves. Radio waves could have unexpected effects on the operation of such medical devices.

#### NOTICE

- Do not leave your portable player in the vehicle. In particular, high temperatures inside the vehicle may damage the portable player.

### Registering/Connecting a Bluetooth® device

To use the Bluetooth® audio system, it is necessary to register a Bluetooth® device with the system.

- ▶ Registering an additional device
  - 1 Display the Bluetooth® audio control screen. (→P.131)
  - 2 Select "Connect".
  - 3 Select "Add device".
- When another Bluetooth® device is connected, a confirmation screen will be displayed. To disconnect the Bluetooth® device, select "Yes".
- 4 Follow the steps in "Registering a Bluetooth® phone for the first time" from step 5. (→P.34)
- ▶ Selecting a registered device
  - 1 Display the Bluetooth® audio control screen. (→P.131)
  - 2 Select "Connect".
  - 3 Select the desired device to be connected.
  - 4 Check that a confirmation screen is displayed when the connection is complete.
- If an error message is displayed,

follow the guidance on the screen to try again.

### **Miracast®**

**Miracast® is a function that enables the audio/visual system to display smartphone's screen and play the smartphone's sound by connecting the smartphone to the audio/visual system with Wi-Fi® connection (P2P mode).**

**This function is not available if the smartphone is not certified by Wi-Fi Alliance® as Miracast® device. (Whether or not a device is a Wi-Fi Alliance® certified Miracast® device can be checked at <https://www.wi-fi.org/>.)**

**While the vehicle is being driven, this function can only output sound.**

- Miracast® performs wireless communication using the same 2.4 GHz radio frequency band as Bluetooth®. Depending on the usage environment, radio wave interference may occur, resulting in image distortion and audio stuttering. If interference occurs, connecting a Bluetooth® cellular phone or portable device that is registered with the system may reduce the effects.
- Miracast® is a registered trademark of Wi-Fi Alliance®.

### **Overview**

The Miracast® control screen can

be reached by the following methods: →P.115

- Connecting a Miracast® device (→P.135)

#### Control screen

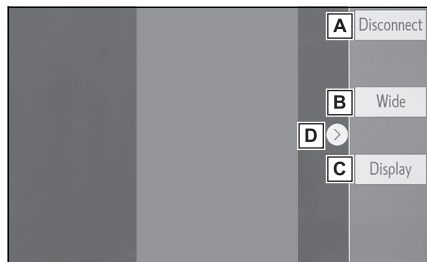

- A** Select to disconnect the Miracast® device.
- B** Select to change the screen size. (→P.117)
- C** Select to display the image quality adjustment screen. (→P.117)
- D** Select to display/hide the control button.

- When “Access to network” (→P.45) is set to “On”, Wi-Fi® network connection communication and Miracast® communication may affect each other, causing image distortion and audio stuttering. If this occurs, setting “Access to network” to “Off” may reduce the effects.
- The Miracast® sound volume takes into account the sound volume of both the system and the connected device. Before using Miracast®, adjust the sound volume of the connected device to an appropriate level.
- When a device that uses Bluetooth®

audio is used with Miracast®, no sound may be output from Miracast®. If this occurs, disabling the Bluetooth® audio may allow sound to be output from Miracast®.

- The Miracast® screen displays the same image that is sent from the external device. If the external device screen is vertically-oriented, the screen may also display a vertical image.

#### WARNING

- Do not connect smartphone or operate the controls while driving.

#### NOTICE

- Do not leave your smartphone in the vehicle. In particular, high temperatures inside the vehicle may damage the smartphone.

#### Connecting a Miracast® device

Miracast® is available when the Wi-Fi® function is enabled. (→P.45)

- 1 Turn the Miracast® function of your smartphone on.
  - 2 Select “Miracast™” on the audio source selection screen. (→P.115)
- The system will automatically start searching for a Miracast® compatible device.

- 3** Check that the following screen is displayed when the device is found.

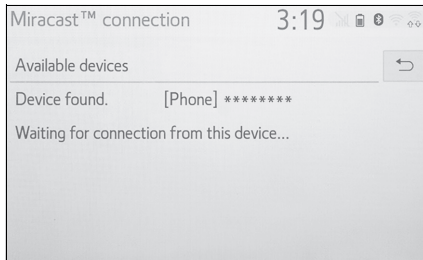

- If the device has been connected to the system before, this screen may not be displayed and the Miracast® connection may start immediately.
- 4** Select the system name on the smartphone.
  - 5** Select “Yes”.

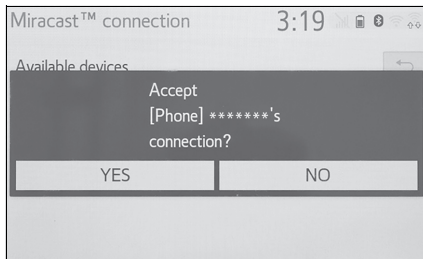

- 6** Check that Miracast® operation screen is displayed.
- Depending on the device connected, it may take approximately 5 to 15 seconds before the Miracast® operation screen is displayed.

- The signal strength/status of the Wi-Fi® connection (P2P mode) is displayed on the upper right side of the

screen. (→P.16)

- To check the Miracast® setting on the Wi-Fi® setting screen (→P.45)
- Miracast® will not be available at the same time using Wi-Fi® connection (P2P mode).

**Steering switches**

**Steering switch operation**

Some parts of the audio/visual system can be adjusted using the switches on the steering wheel.

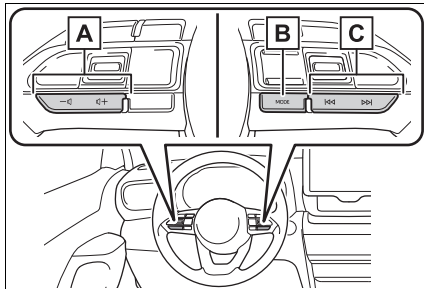

**A** Volume control switch

| Mode | Operation/function                          |
|------|---|
| All  | Press: Volume up/down                       |
|      | Press and hold: Volume up/down continuously |

**B** "MODE" switch

| Mode   | Operation/function  |
|--|---|
| AM/FM/DAB  | Press: Change audio modes   |
|  | Press and hold: Mute (Press and hold again to resume the sound.)      |
| USB, iPod/iPhone, Bluetooth® audio, Android Auto | Press: Change audio modes   |
|  | Press and hold: Pause (Press and hold again to resume the play mode.) |
| Miracast®  | Press: Change audio modes   |

**C** Seek switch

| Mode                               | Operation/function   |
|------------------------------------|--|
| AM/FM                              | Press: Preset stations up/down (Favourites screen)   |
|                                    | Station up/down (Station list screen)  |
|                                    | Seek up/down (Manual tuning screen)  |
|                                    | Press and hold: Seek up/down continuously while the switch is being pressed (Manual tuning screen) |
| DAB                                | Press: Preset services/stations up/down (Favourites screen)  |
|                                    | Service/station up/down (Service/station list screen)  |
|                                    | Seek up/down (Manual tuning screen)  |
|                                    | Press and hold: Seek up/down continuously while the switch is being pressed (Manual tuning screen) |
| USB, iPod/iPhone, Bluetooth® audio | Press: Track/file up/down  |
|                                    | Press and hold: Fast forward/rewind  |
| Android Auto                       | Press: Track up/down   |

### Audio settings

Detailed audio settings can be programmed.

### Displaying the audio settings screen

- 1 Press the "SETUP" button.

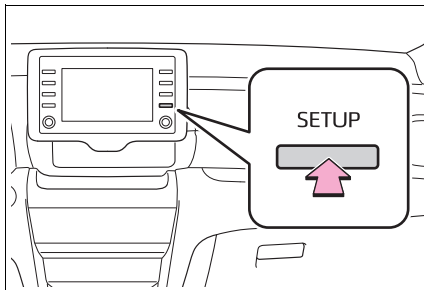

- 2 Select "Audio".
- 3 Select the desired items to be set.

### Audio settings screen

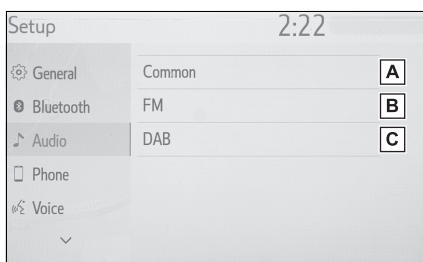

- A** Select to set the common settings. (→P.138)
- B** Select to set detailed FM radio settings. (→P.122)
- C** Select to set detailed DAB set-

tings.\* (→P.122)

\*: If equipped

### Common settings

- 1 Display the audio settings screen. (→P.138)
- 2 Select "Common".
- 3 Select the desired items to be set.

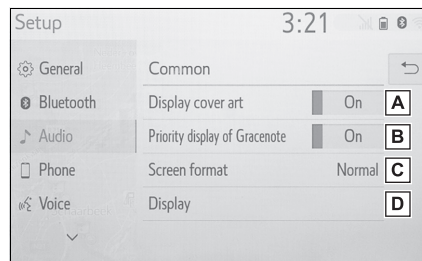

- A** Select to set the cover art display on/off.
- B** Select to prioritize the display of information from the Gracenote database.
- C** Select to change the screen format for video output.\* (→P.117)
- D** Select to display the image quality adjustment screen.\* (→P.118)

\*: Depending on the audio source, some functions may not be available.

**Operating information**

- The use of a cellular phone inside or near the vehicle may cause a noise from the speakers of the audio/visual system which you are listening to. However, this does not indicate a malfunction.

**NOTICE**

- To avoid damage to the audio/visual system:
  - Be careful not to spill beverages over the audio/visual system.

**Radio**

Usually, a problem with radio reception does not mean there is a problem with the radio — it is just the normal result of conditions outside the vehicle.

For example, nearby buildings and terrain can interfere with FM reception. Power lines or phone wires can interfere with AM signals. And of course, radio signals have a limited range. The farther the vehicle is from a station, the weaker its signal will be. In addition, reception conditions change constantly as the vehicle moves.

Here, some common reception problems that probably do not indicate a problem with the radio are described.

■ **FM**

Fading and drifting stations: Generally, the effective range of FM is

about 40 km (25 miles). Once outside this range, you may notice fading and drifting, which increase with the distance from the radio transmitter. They are often accompanied by distortion.

Multi-path: FM signals are reflective, making it possible for 2 signals to reach the vehicle's antenna at the same time. If this happens, the signals will cancel each other out, causing a momentary flutter or loss of reception.

Static and fluttering: These occur when signals are blocked by buildings, trees or other large objects. Increasing the bass level may reduce static and fluttering.

Station swapping: If the FM signal being listened to is interrupted or weakened, and there is another strong station nearby on the FM band, the radio may tune in the second station until the original signal can be picked up again.

■ **AM**

Fading: AM broadcasts are reflected by the upper atmosphere — especially at night. These reflected signals can interfere with those received directly from the radio station, causing the radio station to sound alternately strong and weak.

Station interference: When a reflected signal and a signal received directly from a radio station are very nearly the same fre-

quency, they can interfere with each other, making it difficult to hear the broadcast.

Static: AM is easily affected by external sources of electrical noise, such as high tension power lines, lightning or electrical motors. This results in static.

### iPod/iPhone

#### ■ Certification



- Use of the Made for Apple badge means that an accessory has been designed to connect specifically to the Apple product(s) identified in the badge, and has been certified by the developer to meet Apple performance standards. Apple is not responsible for the operation of this device or its compliance with safety and regulatory standards. Please note that the use of this accessory with an Apple product may affect wireless performance.
- iPhone®, iPod®, iPod nano®, iPod touch®, and Lightning® are trademarks of Apple Inc., registered in the U.S. and other countries.

#### ■ Compatible models

Made for

- iPhone XS Max
- iPhone XS
- iPhone XR
- iPhone X
- iPhone 8
- iPhone 8 Plus
- iPhone 7
- iPhone 7 Plus
- iPhone SE
- iPhone 6s
- iPhone 6s Plus
- iPhone 6
- iPhone 6 Plus
- iPhone 5s
- iPhone 5c
- iPhone 5
- iPod touch (6th generation)
- iPod touch (5th generation)
- iPod nano (7th generation)

- This system only supports audio playback.
- Depending on differences between models or software versions etc., some models might be incompatible with this system.

### High-resolution sound source

This device supports high-resolution sound sources.

The definition of high-resolution is based on the standards of groups such as the CTA (Consumer Technology Association).

Supported formats and playable media are as follows.

### ■ Supported formats

WAV, FLAC, ALAC, OGG Vorbis

### ■ Playable media

USB memory

### File information

#### Compatible USB devices

|                           |                       |
|---------------------------|-----------------------|
| USB communication formats | USB 2.0 HS (480 Mbps) |
| File formats              | FAT 16/32             |
| Correspondence class      | Mass storage class    |

#### Compatible audio format

#### Compatible compressed files

| Item                            | USB                             |
|---------------------------------|---------------------------------|
| Compatible file format          | MP3/WMA/AAC                     |
|                                 | WAV(LPCM)/FLAC /ALAC/OGG Vorbis |
|                                 | MP4/AVI/WMV                     |
| Compatible file format (video)* | MP4/AVI/WMV                     |
| Folders in the device           | Maximum 3000                    |
| Files in the device             | Maximum 9999                    |
| Files per folder                | Maximum 255                     |

\*: USB video only

### Corresponding sampling frequency

| File type   | Frequency (kHz)  |
|---|--|
| MP3 files:<br>MPEG 1 LAYER 3                          | 32/44.1/48   |
| MP3 files:<br>MPEG 2 LSF<br>LAYER 3                   | 16/22.05/24  |
| WMA files:<br>Ver. 7, 8, 9* <sup>1</sup><br>(9.1/9.2) | 32/44.1/48   |
| AAC files:<br>MPEG4/AAC-LC                            | 11.025/12/16/<br>22.05/24/32/<br>44.1/48                         |
| WAV (LPCM)<br>files* <sup>2</sup>                     | 8/11.025/12/16/<br>22.05/24/32/<br>44.1/48/88.2/<br>96/176.4/192 |
| FLAC* <sup>2</sup>                                    | 8/11.025/12/16/<br>22.05/24/32/<br>44.1/48/88.2/<br>96/176.4/192 |
| ALAC* <sup>2</sup>                                    | 8/11.025/12/16/<br>22.05/24/32/<br>44.1/48/64/<br>88.2/96        |
| OGG Vorbis* <sup>2</sup>                              | 8/11.025/16/<br>22.05/32/44.1/<br>48                             |

\*<sup>1</sup>: Only compatible with Windows Media Audio Standard

\*<sup>2</sup>: Sound source of 48kHz or more is down-converted to 48kHz/24bit.

**Corresponding bit rates\*1**

| File type                           | Bit rate (kbps) |
|-------------------------------------|-----------------|
| MP3 files:<br>MPEG 1 LAYER 3        | 32 - 320        |
| MP3 files:<br>MPEG 2 LSF<br>LAYER 3 | 8 - 160         |
| WMA files:<br>Ver. 7, 8             | CBR 48 - 192    |
| WMA files:<br>Ver. 9*2 (9.1/9.2)    | CBR 48 - 320    |
| AAC files:<br>MPEG4/AAC-LC          | 8 - 320         |
| OGG Vorbis                          | 32 - 500        |

\*1: Variable Bit Rate (VBR) compatible

\*2: Only compatible with Windows Media Audio Standard

| File type       | Quantization bit rate (bit) |
|-----------------|-----------------------------|
| WAV(LPCM) files | 16/24                       |
| FLAC            |                             |
| ALAC            |                             |

**Compatible channel modes**

| File type | Channel mode                                    |
|-----------|---|
| MP3 files | Stereo, joint stereo, dual channel and monaural |
| WMA files | 2ch   |

| File type                               | Channel mode                             |
|---|--|
| AAC files                               | 1ch, 2ch (Dual channel is not supported) |
| WAV (LPCM)/<br>FLAC/ALAC/ OGG<br>Vorbis | 2ch                                      |

- MP3 (MPEG Audio Layer 3), WMA (Windows Media Audio) and AAC (Advanced Audio Coding) are audio compression standards.
- This system can play MP3/WMA/AAC files on USB memory.
- MP4, WMV and AVI files can use the following resolutions: 128x96, 160x120, 176x144 (QCIF), 320x240 (QVGA), 352x240 (SIF), 352x288 (CIF), 640x480 (VGA), 720x480 (NTSC), 720x576 (PAL)
- When naming an MP3/WMA/AAC file, add an appropriate file extension (.mp3/.wma/.m4a).
- This system plays back files with .mp3/.wma/.m4a file extensions as MP3/WMA/AAC files respectively. To prevent noise and playback errors, use the appropriate file extension.
- MP3 files are compatible with the ID3 Tag Ver. 1.0, Ver. 1.1, Ver. 2.2 and Ver. 2.3 formats. This system cannot display track title and artist name in other formats.

- WMA/AAC files can contain a WMA/AAC tag that is used in the same way as an ID3 tag. WMA/AAC tags carry information such as track title and artist name.
- The emphasis function is available only when playing MP3 files.
- This system can play back AAC files encoded by iTunes.
- The sound quality of MP3/WMA files generally improves with higher bit rates.
- m3u playlists are not compatible with the audio player.
- MP3i (MP3 interactive) and MP3PRO formats are not compatible with the audio player.
- The player is compatible with VBR (Variable Bit Rate).
- When playing back files recorded as VBR (Variable Bit Rate) files, the play time will not be correctly displayed if the fast forward or reverse operations are used.
- It is not possible to check folders that do not include MP3/WMA/AAC files.
- MP3/WMA/AAC files in folders up to 8 levels deep can be played. However, the start of playback may be delayed when using USB memory containing numerous levels of folders. For this reason, we recommend cre-

ating USB memory with no more than 2 levels of folders.

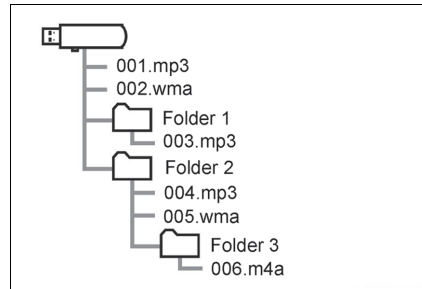

- The play order of the USB memory with the structure shown above is as follows:

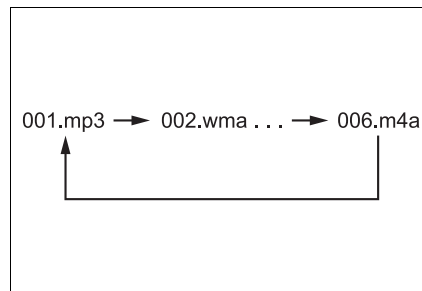

- The order changes depending on the personal computer and MP3/WMA/AAC encoding software you use.

| Compatible video format |   |
|-------------------------|---|
| Format                  | Codec   |
| MPEG-4                  | Video codec: <ul style="list-style-type: none"> <li>• H.264/MPEG-4 AVC</li> <li>• MPEG4</li> </ul> Audio codec: <ul style="list-style-type: none"> <li>• AAC</li> <li>• MP3</li> </ul> Corresponding screen size: <ul style="list-style-type: none"> <li>• MAX 1920×1080</li> </ul> Corresponding frame rate: <ul style="list-style-type: none"> <li>• MAX 60i/30p</li> </ul> |

| Format              | Codec   |
|---------------------|---|
| AVI Container       | Video codec: <ul style="list-style-type: none"> <li>• H.264/MPEG-4 AVC</li> <li>• MPEG4</li> <li>• WMV9</li> <li>• WMV9 Advanced profile</li> </ul> Audio codec: <ul style="list-style-type: none"> <li>• AAC</li> <li>• MP3</li> <li>• WMA9.2 (7, 8, 9.1, 9.2)</li> </ul> Corresponding screen size: <ul style="list-style-type: none"> <li>• MAX 1920×1080</li> </ul> Corresponding frame rate: <ul style="list-style-type: none"> <li>• MAX 60i/30p</li> </ul> |
| Windows Media Video | Video codec: <ul style="list-style-type: none"> <li>• WMV9</li> <li>• WMV9 Advanced profile</li> </ul> Audio codec: <ul style="list-style-type: none"> <li>• WMA9.2 (7, 8, 9.1, 9.2)</li> </ul> Corresponding screen size: <ul style="list-style-type: none"> <li>• MAX 1920×1080</li> </ul> Corresponding frame rate: <ul style="list-style-type: none"> <li>• MAX 60i/30p</li> </ul>  |

**Terms**

■ **ID3 tag**

- This is a method of embedding track-related information in an MP3 file. This embedded information can include the track

number, track title, the artist's name, the album title, the music genre, the year of production, comments, cover art and other data. The contents can be freely edited using software with ID3 tag editing functions. Although the tags are restricted to a number of characters, the information can be viewed when the track is played back.

#### ■ WMA tag

- WMA files can contain a WMA tag that is used in the same way as an ID3 tag. WMA tags carry information such as track title and artist name.

#### ■ MP3

- MP3 is an audio compression standard determined by a working group (MPEG) of the ISO (International Standard Organization). MP3 compresses audio data to about 1/10 the size of that on conventional discs.

#### ■ WMA

- WMA (Windows Media Audio) is an audio compression format developed by Microsoft®. It compresses files into a size smaller than that of MP3 files. The decoding formats for WMA files are Ver. 7, 8 and 9.
- Trademark Acknowledgement  
Windows Media is either a registered trademark or trademark of Microsoft Corporation in the

United States and/or other countries.

This product is protected by certain intellectual property rights of Microsoft. Use or distribution of such technology outside of this product is prohibited without a license from Microsoft.

#### ■ AAC

- AAC is short for Advanced Audio Coding and refers to an audio compression technology standard used with MPEG2 and MPEG4.

#### ■ MPEG4

- This product is licensed under the MPEG-4 patent portfolio license, AVC patent portfolio license and VC-1 patent portfolio license for the personal use of a consumer or other uses in which it does not receive remuneration to
  - encode video in compliance with the MPEG-4 Visual Standard, AVC Standard and VC-1 Standard ("MPEG-4/AVC/VC-1 Video") and/or
  - decode MPEG-4/AVC/VC-1 Video that was encoded by a consumer engaged in a personal activity and/or was obtained from a video provider licensed to provide MPEG-4/AVC/VC-1 Video.
 No license is granted or shall be implied for any other use. Additional information may be obtained from MPEG LA, L.L.C.

See <http://www.mpegla.com>.

**Error messages**

■ **USB**

| Message                 | Explanation   |
|-------------------------|---|
| "USB error"             | This indicates a problem in the USB memory or its connection.           |
| "No music files found." | This indicates that no compatible files are included in the USB memory. |
| "No video files found." | This indicates that no video files are included in the USB memory.      |

■ **iPod**

| Message                 | Explanation   |
|-------------------------|---|
| "iPod error"            | This indicates a problem in the iPod or its connection. |
| "No music files found." | This indicates that there is no music data in the iPod. |

| Message                            | Explanation  |
|------------------------------------|--|
| "Check the iPod firmware version." | This indicates that the firmware version is not compatible. Perform the iPod firmware updates and try again. |
| "iPod authorisation unsuccessful." | This indicates that it failed to authorize the iPod. Please check your iPod.                                 |

■ **Bluetooth® audio**

| Message   | Explanation  |
|---|--|
| "Music tracks not supported. Check your portable player." | This indicates a problem in the Bluetooth® device. |

- If the malfunction is not rectified, take your vehicle to any Toyota retailer or Toyota authorized repairer, or any reliable repairer.

**Speech command system**

**5**

**147**

**5-1. Speech command system operation**

Speech command system **148**

Command list.....**150**

**5**

Speech command system

### Speech command system

The speech command system enables the radio, phone dialing, etc. to be operated using speech commands.

- Voice recognition language can be changed. →P.57
- This function is compatible with the following languages:
  - English
  - French
  - German
  - Spanish
  - Italian
  - Dutch
  - Portuguese
  - Polish
  - Czech
  - Danish
  - Norwegian
  - Swedish
  - Finnish
  - Russian
  - Greek
  - Turkish
  - Flemish

### Using the speech command system

#### ■ Steering switch

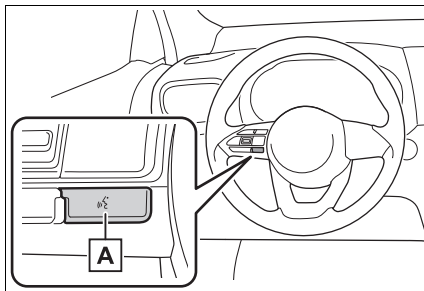

**A** Talk switch

- Press the talk switch to start the speech command system.
- To cancel speech command, press and hold the talk switch.

When an Apple CarPlay/Android Auto connection is established:

- Press and hold the talk switch to start Siri/Google Assistant. To cancel Siri/Google Assistant, press the talk switch.

#### ■ Microphone

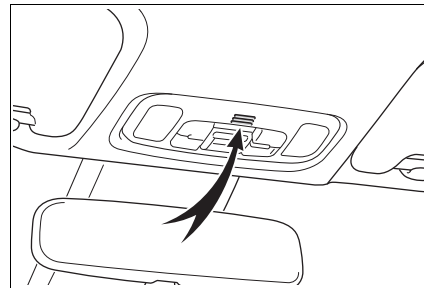

- It is unnecessary to speak directly into the microphone when giving a command.

- Speech commands may not be recognized if:
  - Spoken too quickly.
  - Spoken at a low or high volume.
  - The windows are open.
  - Passengers are talking while speech commands are spoken.
  - The fan speed of the air conditioning system is set at high.
  - The air conditioning vents are turned towards the microphone.
- In the following conditions, the system may not recognize the command properly and using speech commands may not be possible:
  - The command is incorrect or unclear. Note that certain words, accents or speech patterns may be difficult for the system to recognize.
  - There is excessive background noise, such as wind noise.

- Wait for the confirmation beep before speaking a command.
- This system may not operate immediately after the engine switch <power switch> is turned to ACC or ON.

### Speech command system operation

- 1 Press the talk switch.
  - The speech command system is activated.
  - Pressing the talk switch while a voice prompt is playing, will stop the voice recognition prompt and immediately play the start listening tone.
  - While in voice recognition mode, pressing and holding the talk switch for 1 or more seconds cancels voice recognition mode.
- 2 After a beep sounds, say the desired command or select the desired command.

- 2 Say the desired command or select the desired command.

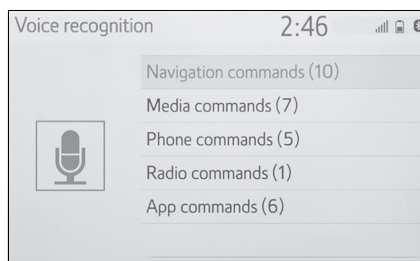

- The command list is read out and the corresponding command is highlighted. To cancel this function, press the talk switch.

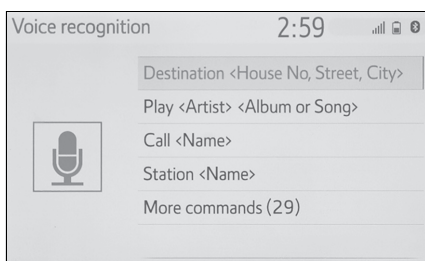

#### ■ Displaying the command list screen

- 1 Say “More commands” or select “More commands” on the speech command main menu screen.

## Command list

### Command list overview

Recognizable speech commands and their actions are shown below.

- Frequently used commands are listed in the following tables.
- For devices that are not installed to the vehicle, commands relating to that device may not function. Also, depending on other conditions, such as compatibility, some commands may not function.
- The functions available may vary according to the system installed.
- When an Apple CarPlay/Android Auto connection is established, some commands will become unavailable.

### Command list

#### ■ Common

| Command      | Action                            |
|--------------|-----------------------------------|
| "Correction" | Returns to the previous state     |
| "Cancel"     | Cancels the speech command system |

#### ■ Top menu

| Command         | Action                               |
|-----------------|--------------------------------------|
| "More commands" | Displays more commonly used commands |

#### ■ Navigation \*

| Command                        | Action                                   |
|--------------------------------|--|
| "Destination <address>"        | Set a destination by saying address      |
| "Enter country <country name>" | Set a destination by saying country name |
| "Enter city <city name>"       | Set a destination by saying city name    |
| "Enter postcode <postcode>"    | Set a destination by saying postcode     |
| "Go home"                      | Set a destination to home                |
| "Favourite <favourite name>"   | Set a destination to <favourite name>    |
| "Find next <POI name>"         | Set a destination to <POI name>          |

| Command               | Action                                      |
|-----------------------|---|
| “Show map”            | Displays the map screen                     |
| “Repeat instructions” | Repeats the last instructions of navigation |

\*: Models with navigation function

#### ■ Media

| Command   | Action   |
|---|--|
| “Play <artist name> <album or song name>” <sup>*1</sup> | Plays tracks from the selected artist and album/song |
| “Artist <artist name>” <sup>*1</sup>                    | Plays tracks from the selected artist                |
| “Album <album name>” <sup>*1</sup>                      | Plays tracks from the selected album                 |
| “Song <song name>” <sup>*1</sup>                        | Plays the selected track                             |
| “Play playlist <playlist name>” <sup>*1, 2</sup>        | Plays tracks from the selected playlist              |

\*1: The audio device must be connected via a USB cable to use the functionality

\*2: Available only for iPod/iPhone

#### ■ Phone

| Command                         | Action   |
|---------------------------------|--|
| “Dial <phone number>”           | Call the selected phone number                             |
| “Redial”                        | Call the phone number of the latest outgoing call          |
| “Call <contacts>”               | Call the selected phone contact                            |
| “Call <contacts> <phone types>” | Call the selected phone contact on its selected phone type |

#### ■ Radio

| Command                  | Action                          |
|--------------------------|---------------------------------|
| “Station <station name>” | Play the selected radio station |

#### ■ App<sup>\*</sup>

| Command                     | Action  |
|-----------------------------|---|
| “Fuel price”                | Displays fuel information                             |
| “Fuel price at destination” | Displays fuel information at your current destination |

## 152 5-1. Speech command system operation

---

| Command                  | Action   |
|--------------------------|--|
| "Parking"                | Displays parking information                             |
| "Parking at destination" | Displays parking information at your current destination |
| "Weather"                | Displays weather information                             |
| "Weather at destination" | Displays weather information at your current destination |

\* : Models with navigation function

## Peripheral monitoring system

### 6

#### 6-1. Rear view monitor system

Rear view monitor system **154**

Rear view monitor system precautions ..... **156**

Things you should know ... **160**

#### 6-2. Panoramic view monitor (vehicles with Toyota Teammate Advanced Park)

Panoramic view monitor (vehicles with Toyota Teammate Advanced Park) ..... **162**

When the shift position is in the "P" ..... **165**

When the shift position is in the "D" or "N" ..... **167**

When the shift position is in the "R" ..... **172**

When folding the outside rear view mirrors ..... **178**

Magnifying function ..... **180**

Customizing the panoramic view monitor ..... **181**

Panoramic view monitor precautions ..... **182**

Things you should know ... **194**

### Rear view monitor system\*

\*: If equipped

**The rear view monitor system assists the driver by displaying an image of the view behind the vehicle with fixed guide lines on the screen while backing up, for example while parking.**

● The screen illustrations used in this text are intended as examples, and may differ from the image that is actually displayed on the screen.

### Driving precautions

The rear view monitor system is a supplemental device intended to assist the driver when backing up. When backing up, be sure to visually check all around the vehicle both directly and using the mirrors before proceeding. If you do not, you may hit another vehicle, and could possibly cause an accident. Pay attention to the following precautions when using the rear view monitor system.

#### WARNING

● Never depend on the rear view monitor system entirely when backing up. The image and the position of the guide lines displayed on the screen may differ from the actual state. Use caution, just as you would when backing up any vehicle.

- Be sure to back up slowly, depressing the brake pedal to control vehicle speed.
- The instructions given are only guide lines. When and how much to turn the steering wheel will vary according to traffic conditions, road surface conditions, vehicle condition, etc. when parking. It is necessary to be fully aware of this before using the rear view monitor system.
- When parking, be sure to check that the parking space will accommodate your vehicle before maneuvering into it.
- Do not use the rear view monitor system in the following cases:
  - On icy or slick road surfaces, or in snow
  - When using tyre chains or emergency tyres
  - When the back door is not closed completely
  - On roads that are not flat or straight, such as curves or slopes
- In low temperatures, the screen may darken or the image may become faint. The image could distort when the vehicle is moving, or you may become unable to see the image on the screen. Be sure to visually check all around the vehicle both directly and using the mirrors before proceeding.
- If the tyre sizes are changed, the position of the fixed guide lines displayed on the screen may change.
- The camera uses a special lens. The distances between objects and pedestrians that appear in the image displayed on the screen will differ from the actual distances. (→P.157)

**Screen description**

The rear view monitor system screen will be displayed if the shift position is shifted to the “R” position while the engine switch <power switch> is in ON.

canceled when the shift lever is shifted into any position other than the “R” position.

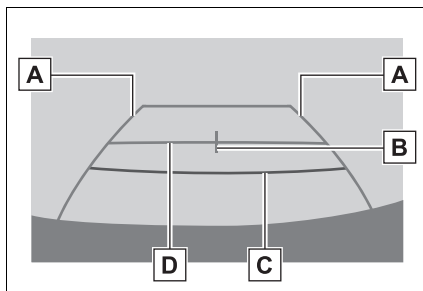
**A** Vehicle width guide line

Displays a guide path when the vehicle is being backed straight up.

- The displayed width is wider than the actual vehicle width.

**B** Vehicle centre guide line

This line indicates the estimated vehicle centre on the ground.

**C** Distance guide line

Shows distance behind the vehicle.

- Displays a point approximately 0.5 m (1.5 ft.) (red) from the edge of the bumper.

**D** Distance guide line

Shows distance behind the vehicle.

- Displays a point approximately 1 m (3 ft.) (blue) from the edge of the bumper.

**Canceling rear view monitor system**

The rear view monitor system is

### Rear view monitor system precautions

#### Area displayed on screen

The rear view monitor system displays an image of the view from the bumper of the rear area of the vehicle.

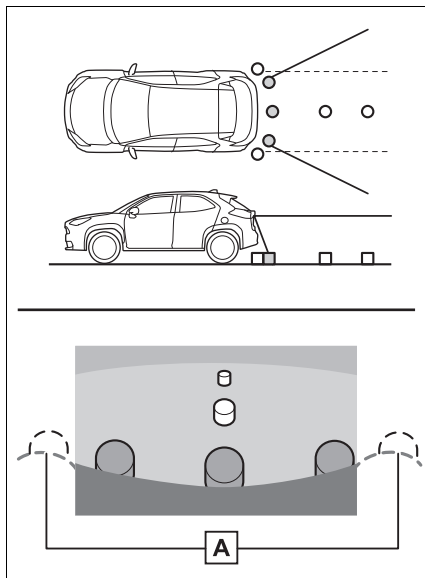

**A** Corners of bumper

- The area around both corners of the bumper will not be displayed.
- The image adjustment procedure for the rear view monitor system screen is the same as the procedure for adjusting the screen. (→P.31)
- The area displayed on the screen may vary according to vehicle orientation conditions.
- Objects which are close to either corner of the bumper or under the bumper cannot be displayed.

- The camera uses a special lens. The distance of the image that appears on the screen differs from the actual distance.
- Items which are located higher than the camera may not be displayed on the monitor.

#### The camera

The camera for the rear view monitor system is located as shown in the illustration.

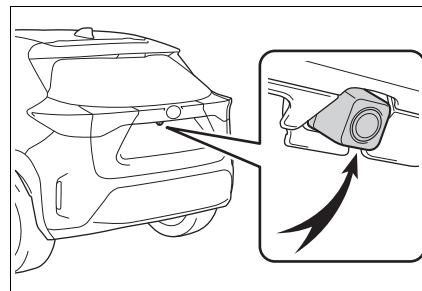

#### Using the camera

If dirt or foreign matter (such as water droplets, snow, mud, etc.) is adhering to the camera, it cannot transmit a clear image. In this case, flush it with a large quantity of water and wipe the camera lens clean with a soft and wet cloth.

#### NOTICE

- The rear view monitor system may not operate properly in the following cases.
  - If the back of the vehicle is hit, the position and mounting angle of the camera may change.
  - As the camera has a water proof construction, do not detach, disassemble or modify it. This may cause incorrect operation.

 NOTICE

- When cleaning the camera lens, flush the camera with a large quantity of water and wipe it with a soft and wet cloth. Strongly rubbing the camera lens may cause the camera lens to be scratched and unable to transmit a clear image.
- Do not allow organic solvent, car wax, window cleaner or a glass coating to adhere to the camera. If this happens, wipe it off as soon as possible.
- If the temperature changes rapidly, such as when hot water is poured on the vehicle in cold weather, the system may not operate normally.
- When washing the vehicle, do not apply intensive bursts of water to the camera or camera area. Doing so may result in the camera malfunctioning.
- Do not expose the camera to strong impact as this could cause a malfunction. If this happens, have the vehicle inspected by any Toyota retailer or Toyota authorized repairer, or any reliable repairer as soon as possible.

**Differences between the screen and the actual road**

- The distance guide lines and the vehicle width guide lines may not actually be parallel with the dividing lines of the parking space, even when they appear to be so. Be sure to check visually.
- The distances between the vehicle width guide lines and the left and right dividing lines of the parking space may not be equal,

even when they appear to be so. Be sure to check visually.

- The distance guide lines give a distance guide for flat road surfaces. In any of the following situations, there is a margin of error between the fixed guide lines on the screen and the actual distance/course on the road.

**■ When the ground behind the vehicle slopes up sharply**

The distance guide lines will appear to be closer to the vehicle than the actual distance. Because of this, objects will appear to be farther away than they actually are. In the same way, there will be a margin of error between the guide lines and the actual distance/course on the road.

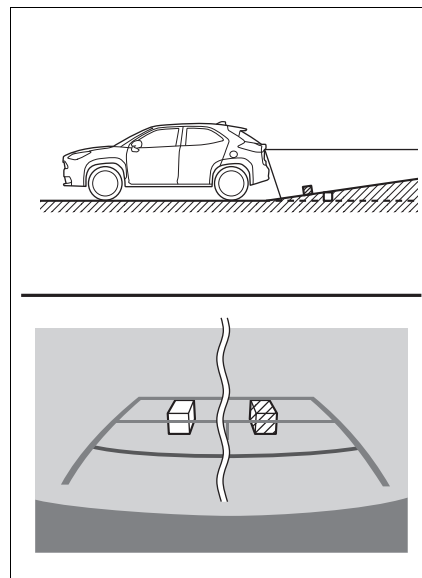

■ **When the ground behind the vehicle slopes down sharply**

The distance guide lines will appear to be farther from the vehicle than the actual distance. Because of this, objects will appear to be closer than they actually are. In the same way, there will be a margin of error between the guide lines and the actual distance/course on the road.

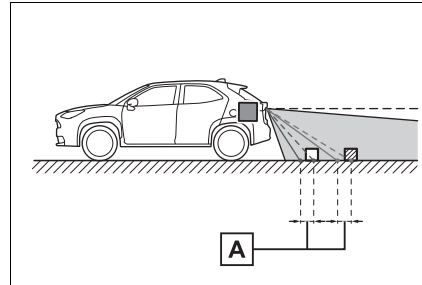

A A margin of error

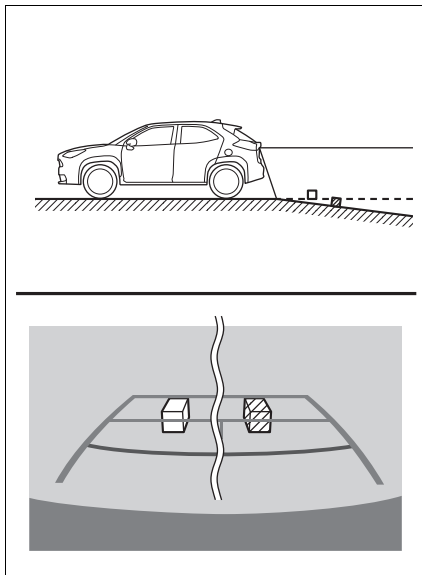

■ **When any part of the vehicle sags**

When any part of the vehicle sags due to the number of passengers or the distribution of the load, there is a margin of error between the fixed guide lines on the screen and the actual distance/course on the road.

**When approaching three-dimensional objects**

The distance guide lines are displayed according to flat surfaced objects (such as the road). It is not possible to determine the position of three-dimensional objects (such as vehicles) using the vehicle width guide lines and distance guide lines. When approaching a three-dimensional object that extends outward (such as the flatbed of a truck), be careful of the following.

■ **Vehicle width guide lines**

Visually check the surroundings and the area behind the vehicle. In the case shown below, the truck appears to be outside of the vehicle width guide lines and the vehicle does not look as if it hits the truck. However, the rear body of the truck may actually cross over the vehicle width guide lines. In reality if you back up as guided by the vehicle width guide lines, the vehicle may hit the truck.

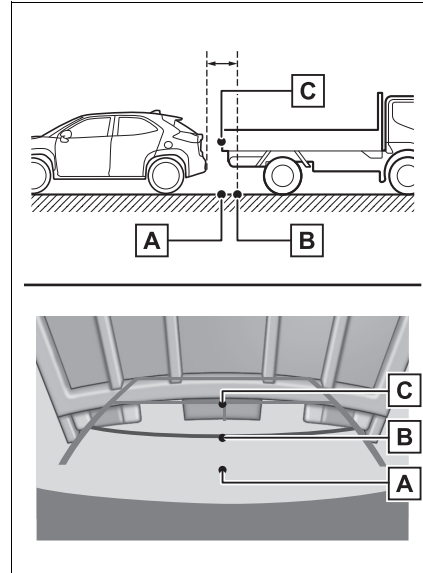
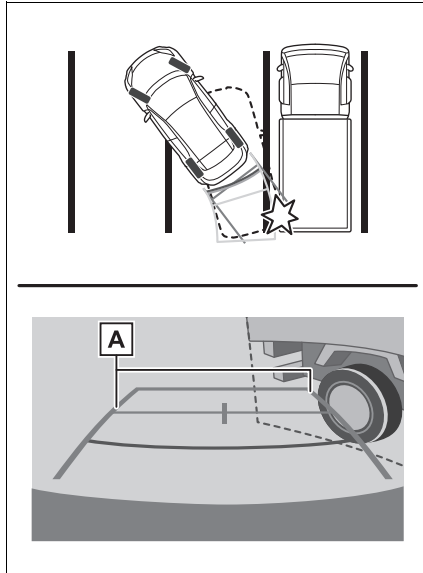

**A** Vehicle width guide lines

■ **Distance guide lines**

Visually check the surroundings and the area behind the vehicle. On the screen, it appears that a truck is parking at point **B**. However, in reality if you back up to point **A**, you will hit the truck. On the screen, it appears that **A** is closest and **C** is farthest away. However, in reality, the distance to **A** and **C** is the same, and **B** is farther than **A** and **C**.

**Things you should know**

**If you notice any symptoms**

If you notice any of the following symptoms, refer to the likely cause and the solution, and re-check.

If the symptom is not resolved by the solution, have the vehicle inspected by any Toyota retailer or Toyota authorized repairer, or any reliable repairer.

| Symptom                       | Likely cause  | Solution   |
|-------------------------------|---|--|
| The image is difficult to see | <ul style="list-style-type: none"> <li>• The vehicle is in a dark area</li> <li>• The temperature around the lens is either high or low</li> <li>• The outside temperature is low</li> <li>• There are water droplets on the camera</li> <li>• It is raining or humid</li> <li>• Foreign matter (mud etc.) is adhering to the camera</li> <li>• Sunlight or headlights are shining directly into the camera</li> <li>• The vehicle is under fluorescent lights, sodium lights, mercury lights etc.</li> </ul> | <p>Back up while visually checking the vehicle's surroundings. (Use the monitor again once conditions have been improved.)</p> <p>The procedure for adjusting the picture quality of the rear view monitor system is the same as the procedure for adjusting the screen. (→P.31)</p> |
| The image is blurry           | Dirt or foreign matter (such as water droplets, snow, mud etc.) is adhering to the camera.  | Flush the camera with a large quantity of water and wipe the camera lens clean with a soft and wet cloth.  |
| The image is out of alignment | The camera or surrounding area has received a strong impact.  | Have the vehicle inspected by any Toyota retailer or Toyota authorized repairer, or any reliable repairer.   |

| Symptom   | Likely cause  | Solution   |
|---|---|--|
| The fixed guide lines are very far out of alignment | The camera position is out of alignment.  | Have the vehicle inspected by any Toyota retailer or Toyota authorized repairer, or any reliable repairer.   |
|   | <ul style="list-style-type: none"> <li>• The vehicle is tilted (there is a heavy load on the vehicle, tyre pressure is low due to a tyre puncture, etc.)</li> <li>• The vehicle is used on an incline.</li> </ul> | <p>If this happens due to these causes, it does not indicate a malfunction.</p> <p>Back up while visually checking the vehicle's surroundings.</p> |

**Panoramic view monitor (vehicles with Toyota Teammate Advanced Park)\***

\*: If equipped

**Panoramic view monitor assists the driver in viewing the surroundings, when operating at low speeds, by combining the front, side and rear cameras and displaying a complete vehicle overhead image on the screen.**

- The screen illustrations used in this text are intended as examples, and may differ from the image that is actually displayed on the screen.

**! WARNING**

- Always make sure to check all around the vehicle with your own eyes when driving.
- The camera uses a special lens. The distances between objects and pedestrians that appear in the image displayed on the screen will differ from the actual distances.

**Camera switch**

The camera switch is located as shown in the illustration.

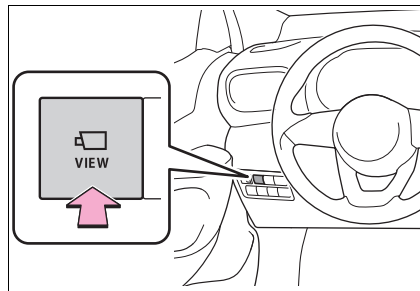

**How to switch the display**

When you press the camera switch or shift the shift position to the “R” while the engine switch <power switch> is in ON, the panoramic view monitor operates. (The following is an example)

- ▶ When the shift position is in the “P”

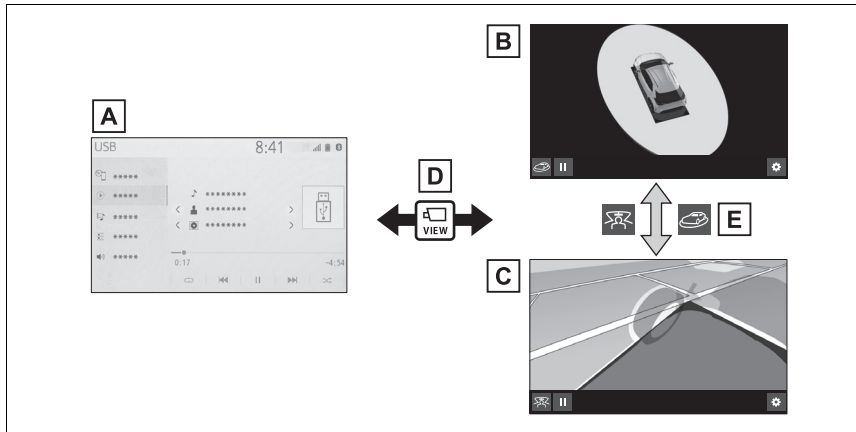

- A** Map screen, audio screen, etc.
- B** Moving view
- C** See-through view
- D** Pressing the camera switch
- E** Selecting the display mode switching button

- ▶ When the shift position is in the “D” or “N”

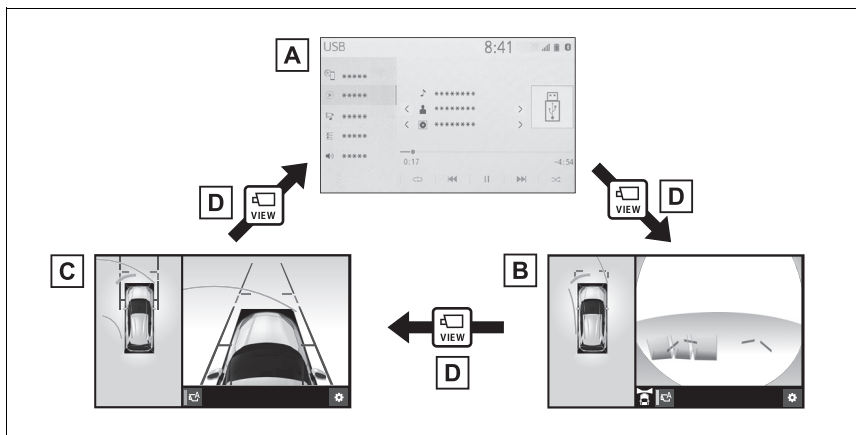

- A** Map screen, audio screen, etc.
- B** Wide front view & panoramic view

- C** Side clearance view & panoramic view
- D** Pressing the camera switch
- ▶ When the shift position is in the “R”

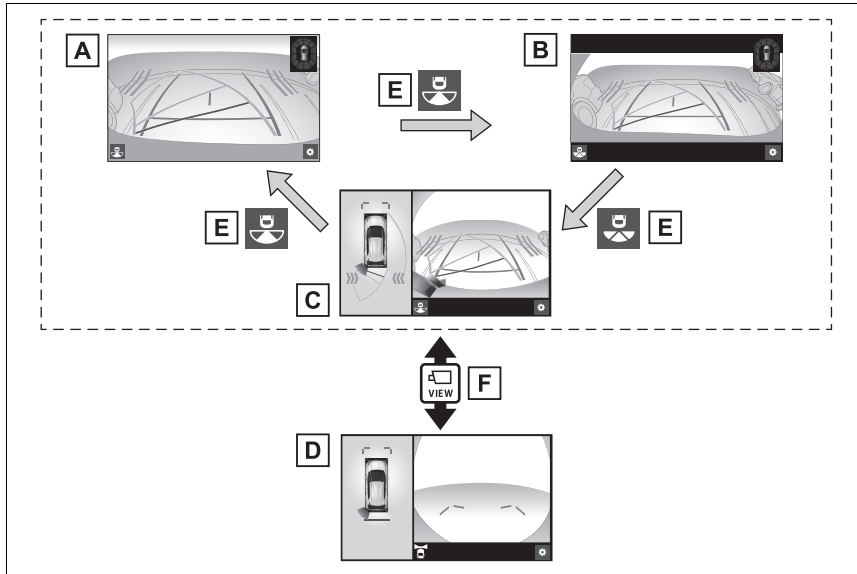

- A** Rear view
- B** Wide rear view
- C** Rear view & panoramic view
- D** Front view & panoramic view
- E** Selecting the display mode switching button
- F** Pressing the camera switch

● The panoramic view monitor is displayed by operating the camera switch when vehicle speed is approximately 20 km/h (12 mph) or less.

### When the shift position is in the “P”

The moving view screen and the see-through view screen provide support when checking the areas of around the vehicle while parking. These screens display an image of the vicinity of the vehicle combined from the 4 cameras. The screen will display a 360° view around the vehicle from either inside the vehicle or from a birds-eye view at an angle.

### Screen display

- 1 Shift the shift position to “P”.
- 2 Press the camera switch.
  - Pressing the camera switch again changes the screen back to the previously displayed screen, such as the navigation screen.
  - Each time the display mode switching button is selected, the mode will change as follows:
    - ▶ See-through view

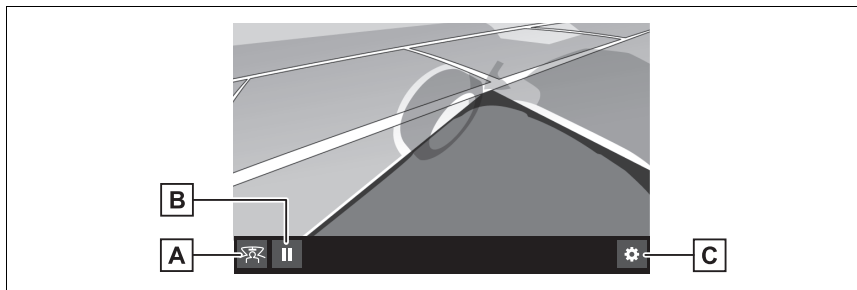

- ▶ Moving view

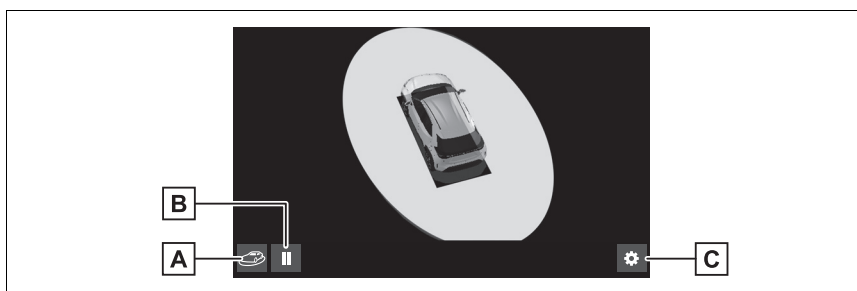

- ▶ **A** Display mode switching button

Select to change the display mode between the moving view and the see-through view.

**B** Rotation pause/resume button

Select to pause/resume the rotation of the screen.

**C** Customize settings button

Settings such as the guide line display mode, vehicle body color on the screen and the detection distance of Toyota parking assist-sensor can be changed. (→P.181)

- 
- The see-through view screen and moving view screen can be displayed only when the Toyota parking assist-sensor is ON. For details about the Toyota parking assist-sensor, refer to the “Owner’s Manual”.
  - The rotation display of the see-through view/moving view screen can be paused and resumed by selecting any place on the screen.
  - A different screen is displayed when the Toyota Teammate Advanced Park is activated. For details about the Toyota Teammate Advanced Park, refer to the “Owner’s Manual”.

### When the shift position is in the “D” or “N”

The wide front view & panoramic view screen provides support when checking the areas in front of the vehicle and around the vehicle when taking-off at T-intersections or other intersections during poor visibility.

In addition, the side clearance view & panoramic view screen provide support to check the areas around the sides of the vehicle when driving on a narrow road.

### Screen display

- 1 Shift the shift position to “D” or “N”.
  - 2 Press the camera switch.
    - The screen mode switches each time the camera switch is pressed.
- ▶ Wide front view & panoramic view

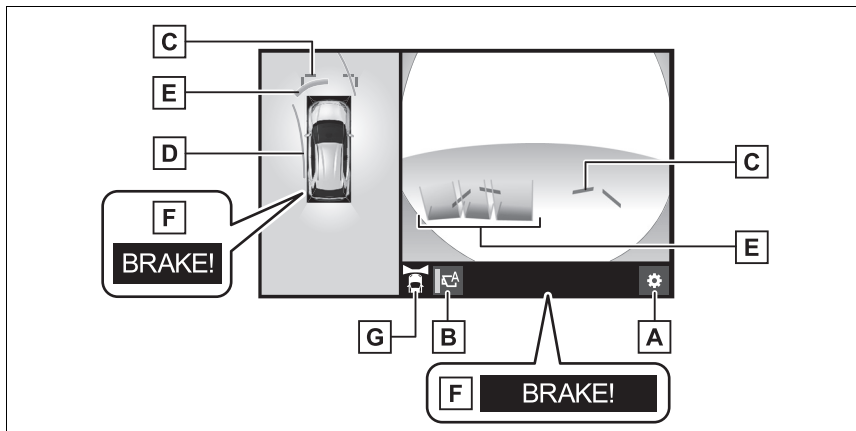

**A** Customize settings button

Settings such as the guide line display mode, vehicle body color on the screen and the detection distance of Toyota parking assist-sensor can be changed. (→P.181)

**B** Automatic display button

Select to turn automatic display mode on/off. When the shift position is “D” or “N”, the wide front view & panoramic view or side clearance view & panoramic view are automatically displayed according to the vehicle speed. (→P.170)

**C** Distance guide lines

Show distance in front of the vehicle.

- Display points approximately 1 m (3 ft.) from the edge of the bumper.

**D** Estimated course lines

Show an estimated course when the steering wheel is turned.

- These lines will be displayed when the steering wheel is turned more than 90° from the center.

**E** Toyota parking assist-sensor\*

When a sensor detects an obstacle, the direction of and the approximate distance to the obstacle are displayed and the buzzer sounds.

For details about the Toyota parking assist-sensor, refer to the “Owner’s Manual”.

**F** Parking Support Brake\*

When the system determines that the possibility of a frontal collision with a detected object is high, a warning message is displayed.

For details about the Parking Support Brake, refer to the “Owner’s Manual”.

**G** Display area icon

Show the current display area by an icon.

\*: If equipped

▶ Side clearance view & panoramic view

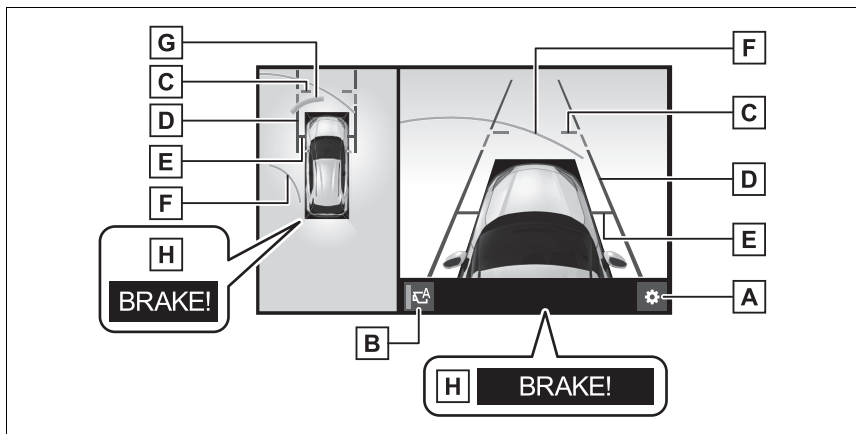

**A** Customize settings button

Settings such as the guide line display mode, vehicle body color on the screen and the detection distance of Toyota parking assist-sensor can be changed. (→P.181)

**B** Automatic display button

Select to turn automatic display mode on/off. When the shift position is “D” or “N”,

the wide front view & panoramic view or side clearance view & panoramic view are automatically displayed according to the vehicle speed. (→P.170)

**C** Distance guide lines

Show distance in front of the vehicle.

- Display points approximately 1 m (3 ft.) from the edge of the bumper.

**D** Vehicle width guide lines

Shows guide lines of the vehicle's width including the outside rear view mirrors.

**E** Front tire guide lines

Show guide lines of where the front tire touches the ground.

**F** Estimated course lines

Show an estimated course when the steering wheel is turned.

- These lines will be displayed when the steering wheel is turned by 90° or more from the center (straight-line) position.

**G** Toyota parking assist-sensor \*

When a sensor detects an obstacle, the direction of and the approximate distance to the obstacle are displayed and the buzzer sounds.

For details about the Toyota parking assist-sensor, refer to the "Owner's Manual".

**H** Parking Support Brake \*

When the system determines that the possibility of a collision with a detected object is high, a warning message is displayed.

For details about the Parking Support Brake, refer to the "Owner's Manual".

\*: If equipped

- The side clearance view screen can be displayed only when the Toyota parking assist-sensor is ON. For details about the Toyota parking assist-sensor, refer to the "Owner's Manual".
- A different screen is displayed when the Toyota Teammate Advanced Park is activated. For details about the Toyota Teammate Advanced Park, refer to the "Owner's Manual".



**WARNING**

- When a sensor indicator on the Toyota parking assist-sensor display illuminates in red or a buzzer sounds continuously, be sure to check the area around the vehicle immediately and do not proceed any further until safety has been ensured, otherwise an unexpected accident may occur.
- As the Toyota parking assist-sensor display is displayed over the camera view, it may be difficult to see the Toyota parking assist-sensor display depending on the color and brightness of the surrounding area.

### Switching the guide line mode

The guide line mode can be switched in the customization settings. (→P.181)

▶ Distance guide line

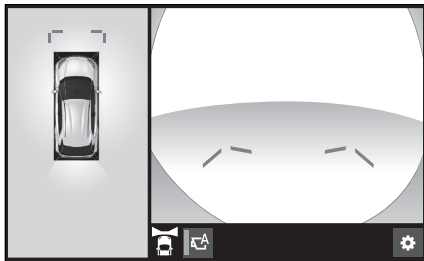

- Only the distance guide lines are displayed.

▶ Estimated course line

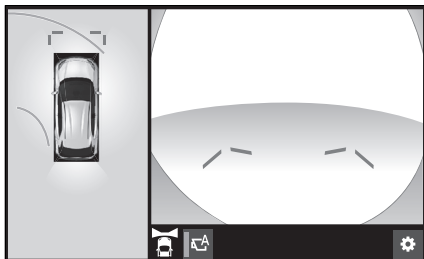

- Estimated course lines will be added to the distance guide lines.

### Automatic display mode

In addition to screen switching by operating the camera switch, automatic display mode is available. In this mode, the screen is switched automatically in response to vehicle speed.

Each time is selected, automatic display mode is enabled/disabled.

In automatic mode, the monitor will automatically display images in the following situations:

- When the shift position is shifted to “N” or “D” position.
- When vehicle speed is reduced to approximately 10 km/h (6 mph) or less.

### Using the vehicle width guide line

▶ Side clearance view & panoramic view

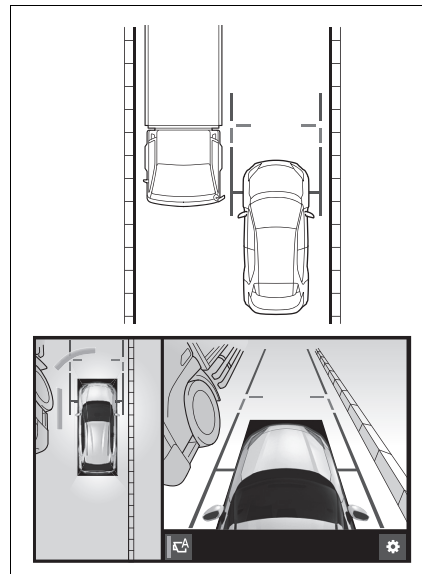

- Check the positions and distance between the vehicle width guide line and a target object such as the obstacle or curb of the road.

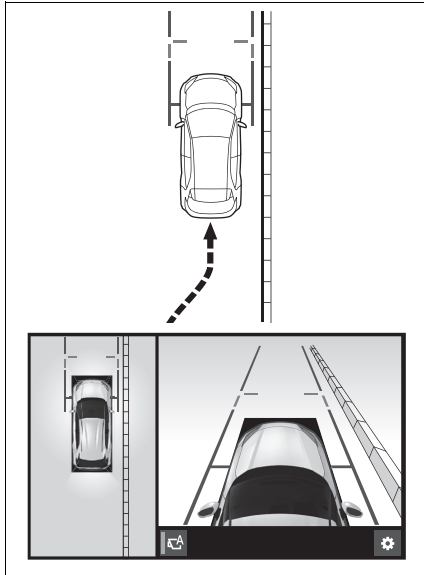

- Pull over to the curb as shown in the illustration above, taking care not to let the vehicle width guide line overlap the target object.
- Ensure that the vehicle width guide line is parallel to the target object.

### When the shift position is in the “R”

The rear view & panoramic view screen, wide rear view screen, rear view screen provide support when checking the areas of behind the vehicle and around the vehicle while backing up, for example while parking.

### Screen display

- 1 Shift the shift position to “R”.
  - Each time the display mode switching button is selected, the mode will change as follows:
    - ▶ Rear view & panoramic view

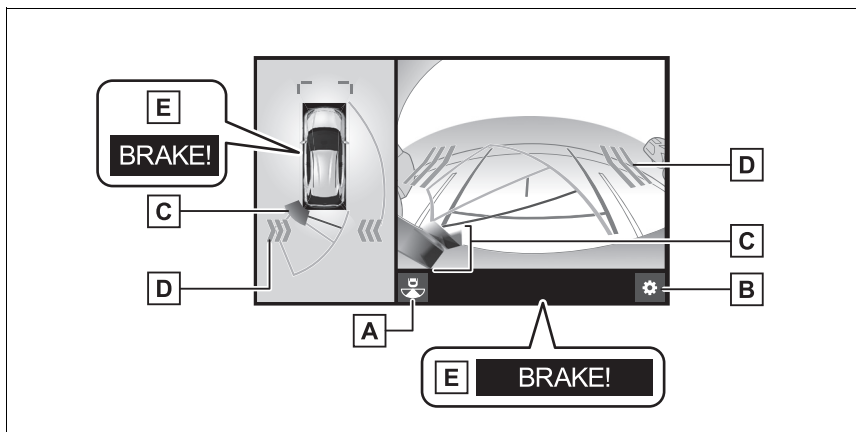

## ▶ Wide rear view

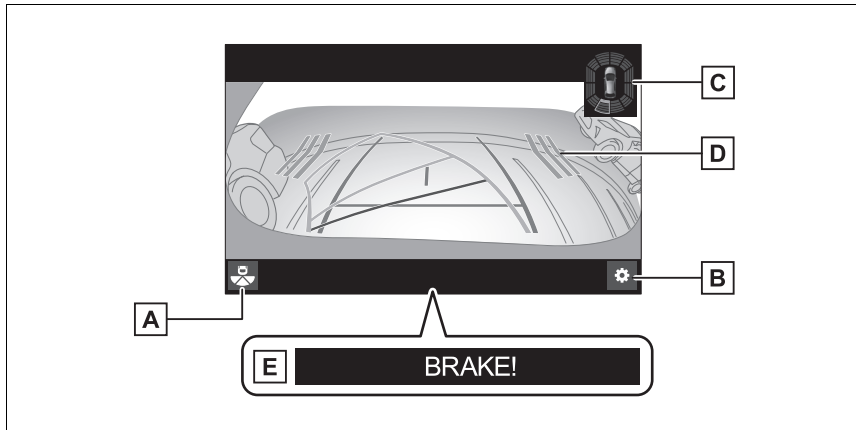

## ▶ Wide rear view

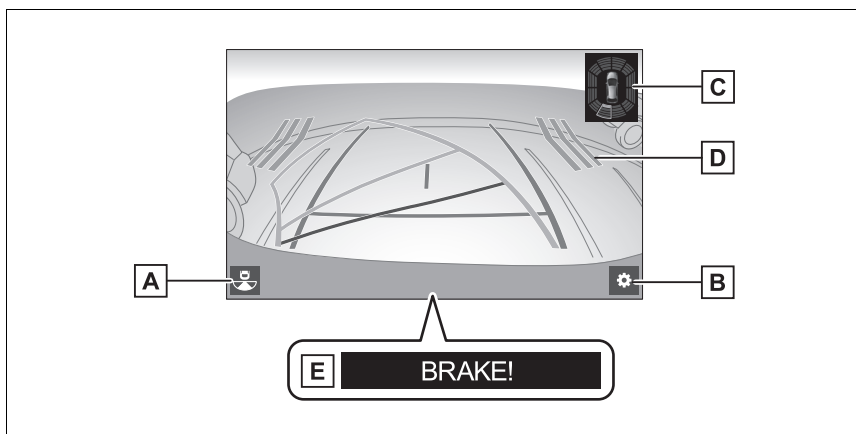
**A** Display mode switching button

Each time the button is selected, the display mode will change as follows:

- Rear view & panoramic view
- Wide rear view
- Rear view

**B** Customize settings button

Settings such as the guide line display mode, vehicle body color on the screen and the detection distance of Toyota parking assist-sensor can be changed. (→P.181)

**C** Toyota parking assist-sensor\*

When a sensor detects an obstacle, the direction of and the approximate distance to

the obstacle are displayed and the buzzer sounds.

For details about the Toyota parking assist-sensor, refer to the "Owner's Manual".

**D** Rear Crossing Traffic Alert\*

When a sensor detects an obstacle, the direction of obstacle is displayed and the buzzer sounds.

For details about the Rear Crossing Traffic Alert, refer to the "Owner's Manual".

**E** Parking Support Brake\*

When the system determines that the possibility of a collision with a detected object is high, a warning message is displayed.

For details about the Parking Support Brake, refer to the "Owner's Manual".

\*: If equipped

● A different screen is displayed when the Toyota Teammate Advanced Park is activated. For details about the Toyota Teammate Advanced Park, refer to the "Owner's Manual".

**! WARNING**

- When a sensor indicator on the Toyota parking assist-sensor display illuminates in red or a buzzer sounds continuously, be sure to check the area around the vehicle immediately and do not proceed any further until safety has been ensured, otherwise an unexpected accident may occur.
- As the Rear Crossing Traffic Alert display is displayed over the camera view, it may be difficult to see the Rear Crossing Traffic Alert display depending on the color and brightness of the surrounding area.

**Guide lines displayed on the screen**

The guide line mode can be switch in the customization settings. (→P.181)

▶ Estimated course line

Estimated course lines are displayed which move in accordance with the operation of the steering wheel.

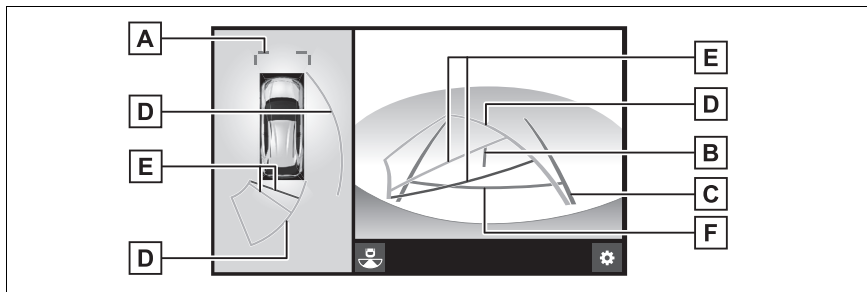

► Parking assist guide line

The steering wheel return points (parking assist guide lines) are displayed. This mode is recommended for those who are comfortable with parking the vehicle without the aid of the estimated course lines.

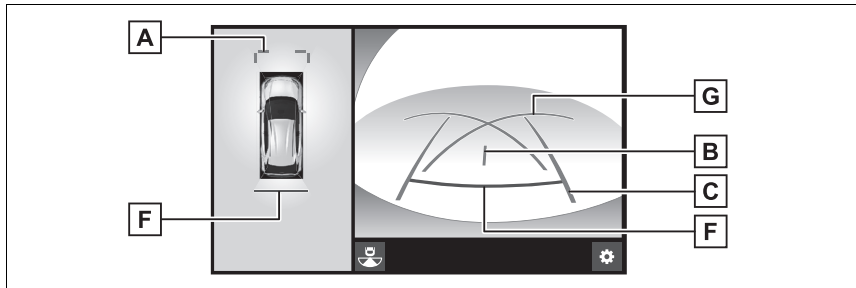

► Distance guide line

Only distance guide line is displayed.

This mode is recommended for those who are comfortable with parking the vehicle without the aid of the guide lines.

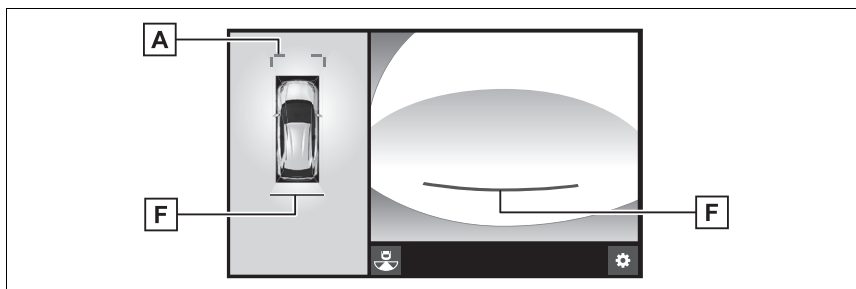

**A** Distance guide lines

Shows distance in front of the vehicle.

- Display points approximately 1 m (3 ft.) from the edge of the bumper.

**B** Vehicle center guide line

The line indicates the estimated vehicle center on the ground.

**C** Vehicle width guide lines

Display a guide path when the vehicle is being backed straight up.

**D** Estimated course lines

Show an estimated course when the steering wheel is turned.

**E** Distance guide lines

Show the distance behind the vehicle when the steering wheel is turned.

- The guide lines move in conjunction with the estimated course lines.
- The guide lines display points approximately 0.5 m (1.5 ft.) (red) and approximately 1 m (3 ft.) (yellow) from the center of the edge of the bumper.

**F** Distance guide line

Shows the distance behind the vehicle.

- Displays a point approximately 0.5 m (1.5 ft.) (red/blue) from the edge of the bumper.

**G** Parking assist guide lines

Show the path of the smallest turn possible behind the vehicle.

**! WARNING**

- Depending on the circumstances of the vehicle (number of passengers, amount of luggage, etc.), the position of the guide lines displayed on the screen may change. Be sure to check visually around the vehicle before proceeding.
- If the steering wheel is straight and the vehicle width guide lines and the estimated course lines are not in alignment, have the vehicle inspected by your Toyota retailer or Toyota authorized repairer, or any reliable repairer.
- Do not use the system if the display is incorrect due to an uneven (hilly) road or a non-straight (curvy) road.

**Parking**

**Using the estimated course line**

When parking in a space which is in the reverse direction to the space described in the procedure below, the steering directions will be reversed.

- 1 Shift the shift position to the "R" position.
- 2 Turn the steering wheel so that the estimated course lines are

within the parking space, and back up slowly.

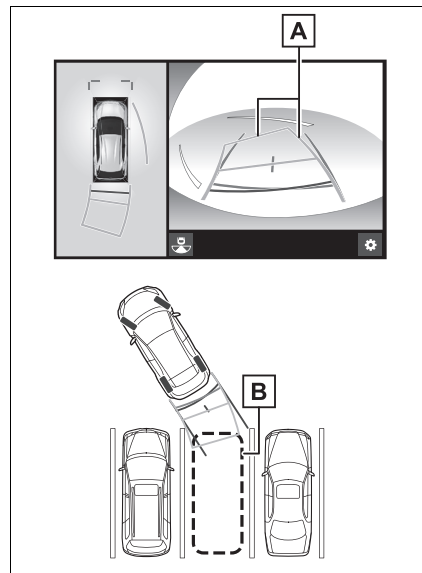

**A** Estimated course lines

**B** Parking space

- 3** When the rear position of the vehicle has entered the parking space, turn the steering wheel so that the vehicle width guide lines are within the left and right dividing lines of the parking space.

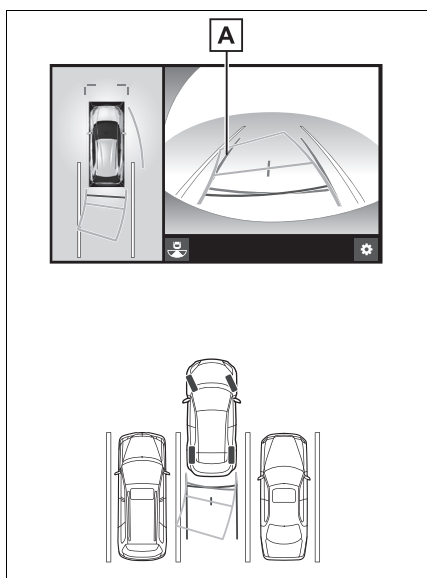

**A** Vehicle width guide line

- 4** Once the vehicle width guide lines and the parking space lines are parallel, straighten the steering wheel and back up slowly until the vehicle has completely entered the parking space.
- 5** Stop the vehicle in an appropriate place, and finish parking.

### Using parking assist guide line

When parking in a space which is in the reverse direction to the space described in the procedure below, the steering directions will be reversed.

- 1** Shift the shift position to the “R” position.
- 2** Back up until the parking assist guide line meets the edge of the left-hand dividing line of the parking space.

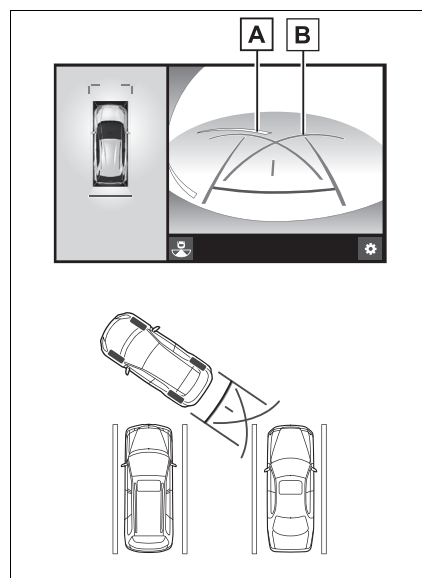

**A** Parking space dividing line

**B** Parking assist guide line

- 3** Turn the steering wheel all the way to the right, and back up slowly.

6

Peripheral monitoring system

- 4 Once the vehicle is parallel with the parking space, straighten the steering wheel and back up slowly until the vehicle has completely entered the parking space.
- 5 Stop the vehicle in an appropriate place, and finish parking.

**When folding the outside rear view mirrors**

Even when outside rear view mirrors are stored, the monitor can display various images of the vicinity of the vehicle and assist the operation in the confirming safe conditions in a narrow places, parking, etc.

**When the shift position is in the “P”**

- ▶ Wide front view & side view

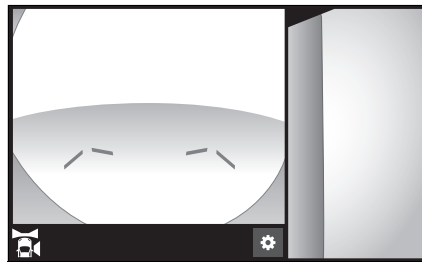

**When the shift position is in the “D” or “N”**

- ▶ Wide front view & side view

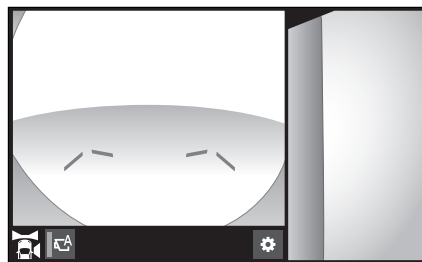

## ▶ Side views



- The screen mode switches each time the camera switch is pressed.

**When the shift position is in the “R”**

## ▶ Rear view &amp; side view

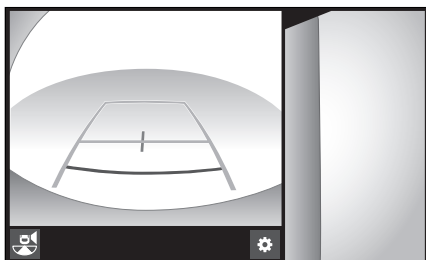
**⚠ WARNING**

- When a sensor indicator on the Toyota parking assist-sensor display illuminates in red or a buzzer sounds continuously, be sure to check the area around the vehicle immediately and do not proceed any further until safety has been ensured, otherwise an unexpected accident may occur.

### Magnifying function

If displayed objects are too small to see clearly when the panoramic view is displayed, the area around the corners of the vehicle can be magnified.

### Magnifying the display

- 1 Select the area on the panoramic view display you wish to magnify.

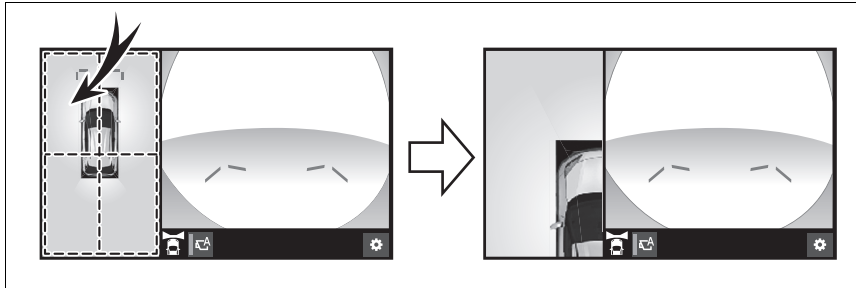

- Selected area on the panoramic view display will magnify.
  - To return to the normal view, select the panoramic view display again.
- 
- The magnifying function is enabled when all of the following conditions are met:
    - The vehicle speed is below approximately 12 km/h (7 mph).
    - The Toyota parking assist-sensor is on.
  - In the following situations, the magnified display will be canceled automatically:
    - The vehicle speed is approximately 12 km/h (7 mph) or higher.
    - The Toyota parking assist-sensor is turned off.
  - When the display is magnified, the guide lines will not be displayed.

### Customizing the panoramic view monitor

Settings, such as the guide line display mode, vehicle body color on the screen, and the detection distance of Toyota parking assist, can be changed.

### Displaying the customize settings screen

- 1 Select .

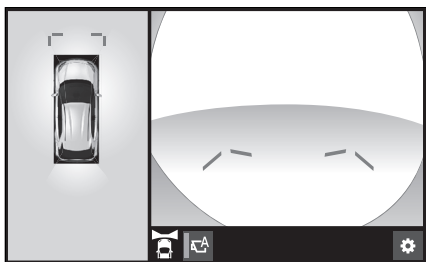

- To ensure safety, the customize settings screen cannot be displayed while driving.
- 2 Select the desired items to be set.

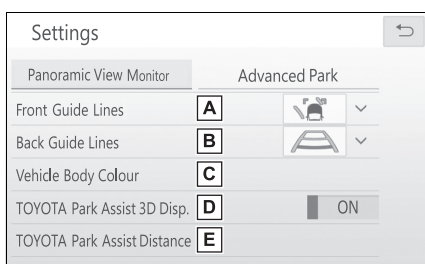

- A Select to switch the guide line mode on the front view screen.

(→P.170)

- B Select to switch the guide line mode on the rear view screen. (→P.174)
- C Select to change the vehicle body color displayed in the panoramic view monitor. (→P.181)
- D Select to turn the Toyota parking assist-sensor indicator on/off. When the display mode is ON, the Toyota parking assist-sensor indicator is displayed in 3D.
- E Select to change the detection start distance of Toyota parking assist-sensor. (→P.181)

### Changing the vehicle body color displayed in the panoramic view monitor

- 1 Select "Vehicle Body Colour".
- 2 Select the desired color.

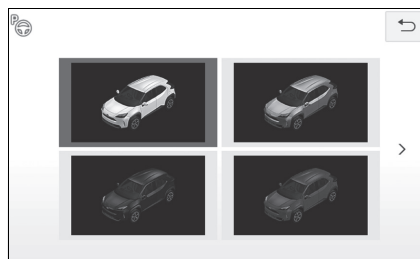

### Changing the detection start distance of Toyota parking assist-sensor

- 1 Select "TOYOTA Park Assist Distance".

- 2 Select the desired detection start distance.

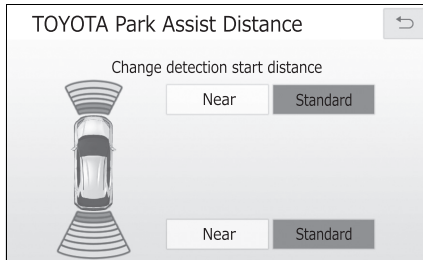

## Panoramic view monitor precautions

### Driving precautions

The panoramic view monitor is a supplemental device intended to assist the driver when checking around the vehicle. When using, be sure to visually check all around the vehicle both directly and using the mirrors before proceeding. If you do not, you may hit another vehicle or possibly cause an accident.

Pay attention to the following precautions when using the panoramic view monitor.

#### WARNING

- Never depend on the panoramic view monitor entirely. The image and the position of the guide lines displayed on the screen may differ from the actual state. Use caution just as you would when driving any other vehicle.
- Always make sure to check all around the vehicle with your own eyes when driving.
- Never drive while looking only at the screen as the image on the screen is different from actual conditions. If you are driving while looking only at the screen, you may hit a person or an object, resulting in an accident. When driving, be sure to check the vehicle's surroundings with your own eyes and the vehicle's mirrors.

**⚠ WARNING**

- Depending on the circumstances of the vehicle (number of passengers, amount of luggage, etc.), the position of the guide lines displayed on the screen may change. Be sure to check visually around the vehicle before proceeding.
- Do not use the panoramic view monitor system in the following cases:
  - On icy or slick road surfaces, or in snow
  - When using tire chains or emergency tires
  - When the front door or back door is not closed completely
  - On roads that are not flat or straight, such as curves or slopes
  - If the suspension has been modified or tires of a size other than specified are installed
- In low temperatures, the screen may darken or the image may become faint. The image could distort when the vehicle is moving, or you may become unable to see the image on the screen. Be sure to visually check all around the vehicle both directly and using the mirrors before proceeding.
- If the tire sizes are changed, the position of the guide lines displayed on the screen may change.
- The camera uses a special lens. The distances between objects and pedestrians that appear in the image displayed on the screen will differ from the actual distances. (→P.189)

**⚠ NOTICE**

- In panoramic view/moving view/see-through view/side clearance view, the system combines images taken from the front, back, left and right side cameras into a single image. There are limits to the range and content that can be displayed. Familiarize yourself with the characteristics of the panoramic view monitor system before using it.
- Image clarity may decline at the four corners of the panoramic view/moving view/see-through view/side clearance view. However, this is not a malfunction, as these are the regions along the border of each camera image where the images are combined.
- Depending on lighting conditions near each of the cameras, bright and dark patches may appear on the panoramic view/moving view/see-through view/side clearance view.
- The panoramic view/moving view/see-through view/side clearance view display does not extend higher than the installation position and image capture range of each camera.
- There are blind spots around the vehicle. Accordingly, there are regions not displayed in panoramic view/moving view/see-through view/side clearance view.
- Three-dimensional objects displayed in side view, wide front view or rear view may not be displayed in panoramic view/moving view/see-through view/side clearance view.

**NOTICE**

- People and other three-dimensional obstacles may appear differently when displayed on the panoramic view monitor. (These differences include, among others, cases in which displayed objects appear to have fallen over, disappear near image processing areas, appear from image processing areas, or when the actual distance to an object differs from the displayed position.)
- When the back door, which is equipped with the back camera, or front doors, which are equipped with door mirrors that have built-in side cameras, are open, images will not be displayed properly on the panoramic view monitor.
- The vehicle icon displayed in panoramic view/moving view/see-through view/side clearance view is a computer generated image. Accordingly, properties such as the color, shape and size will differ from the actual vehicle. For this reason, nearby three-dimensional objects may appear to be touching the vehicle, and actual distances to three-dimensional objects may differ from those displayed.

**Area displayed on screen****Area of image of panoramic view**

The panoramic view monitor displays an image of the surrounding view of the vehicle.

Since the panoramic view processes and displays images based on flat road surfaces, it cannot depict the position of three-dimension objects (such as vehicle bumpers, etc.) that are in positions higher than the surface of the road. Even if there is room between the bumpers of the vehicles and it seems not likely to collide in the image, in reality, the both vehicles are on a collision course.

Check the safety of the surroundings directly.

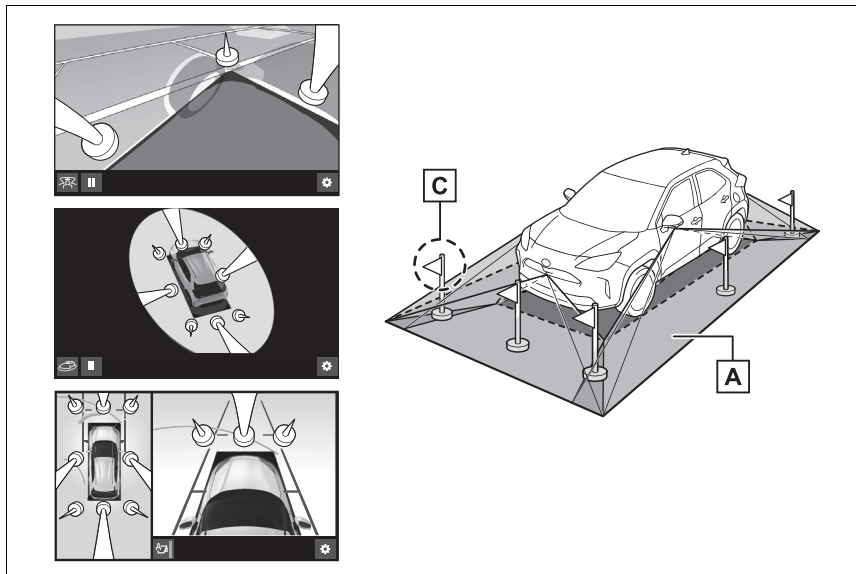
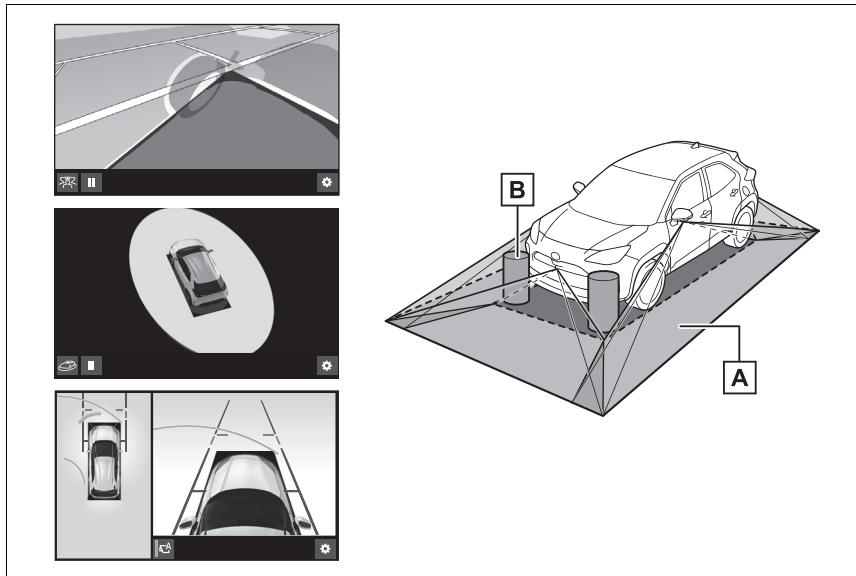

**A** The area displayed on the screen

**B** The objects not displayed on the screen

- Objects located in the shaded areas will not be displayed on the screen.

**C** The parts of objects not displayed on the screen

- Parts of objects which extend above a certain height cannot be displayed on the screen.

- As the images obtained from four cameras are processed and displayed on the standard of a flat road surface; the panoramic view/moving view/see-through view/side clearance view may be displayed as follows.
- Objects may look collapsed; thinner or bigger than usual.
- An object with a higher position than the road surface may look farther away than it actually is or may not appear at all.
- Tall objects may appear protruding from the non-displayed areas of the image.
- Variations in the brightness of the image may appear for every camera.
- The displayed image may be shifted by inclination of the vehicle body, change in vehicle height, etc., depending on the number of passengers, amount of luggage, fuel quantity, etc.
- If the front doors or back door are not completely closed; neither the image nor the guide lines are displayed.
- The position relations of the vehicle icon and the road surface or obstacle may differ from the actual positions.
- The black areas of the vicinity of the vehicle icon are areas that are not captured by the camera.
- Images like the following are combined, thus some areas may be difficult to view.

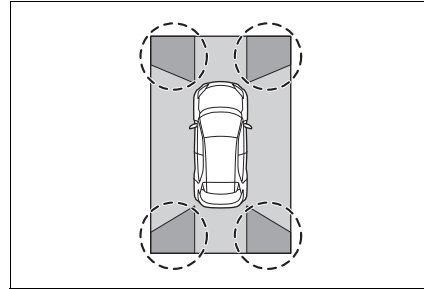

**Area of the image captured by the camera**

► Wide front view

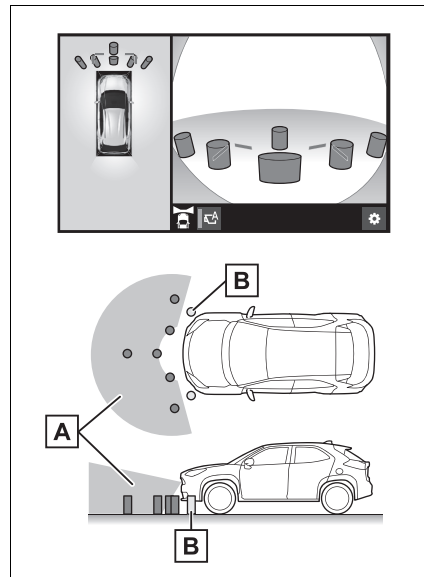

- ▶ Side view (when the outside rear view mirrors are folded)

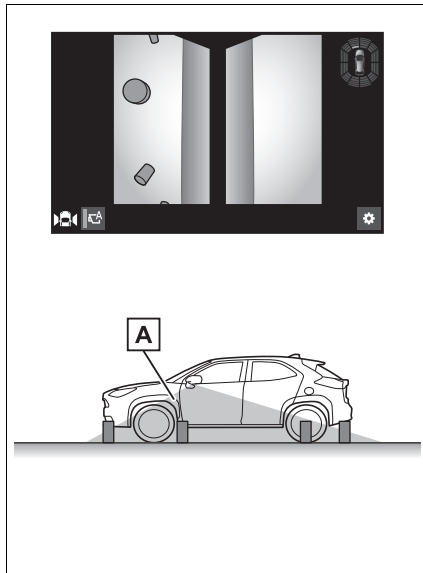

- ▶ Rear view

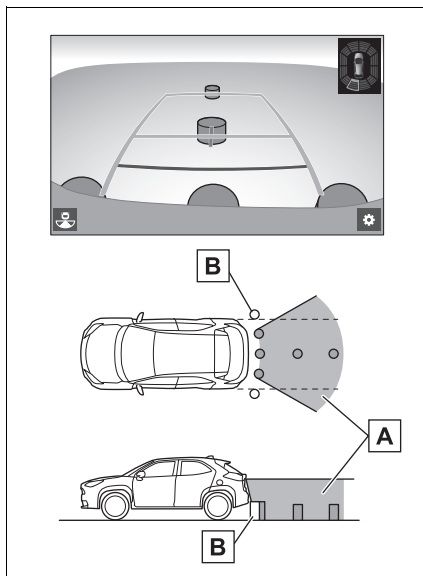

- ▶ Wide rear view

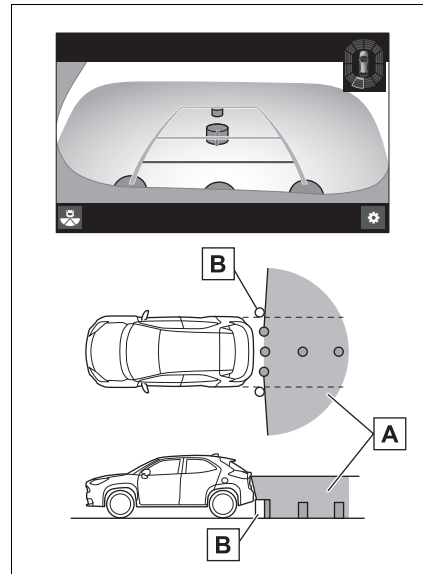

**A** The area displayed on the screen

**B** The objects not displayed on the screen

- Black masking is done for distance detection differences to the front of the vehicle.
- The area covered by the camera is limited. Objects which are close to either corner of the bumper or under the bumper cannot be seen on the screen.
- The area displayed on the screen may vary depending on vehicle orientation or road conditions.
- The camera uses a special lens. The distance in the image displayed on the screen will differ from the actual distance.

### The camera

The cameras for the panoramic view monitor are located as shown in the illustration.

#### ► Front camera

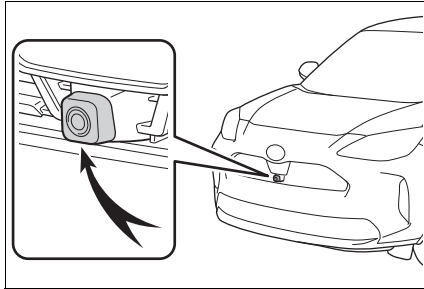

#### ► Side cameras

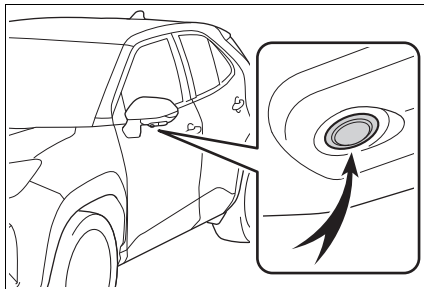

#### ► Rear camera

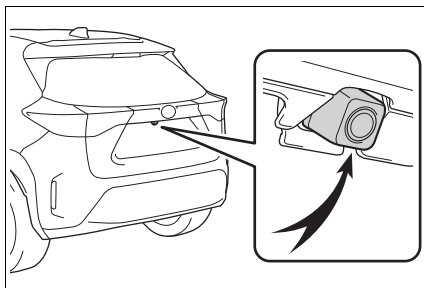

### ■ Using the camera

If dirt or foreign matter (such as water droplets, snow, mud etc.) is adhering to the camera, it cannot

transmit a clear image. In this case, flush it with a large quantity of water and wipe the camera lens clean with a soft and wet cloth.

#### ⚠ NOTICE

- The panoramic view monitor may not operate properly in the following cases.
  - If the camera is hit, the position and mounting angle of the camera may change.
  - As the camera has a water proof construction, do not detach, disassemble or modify it. This may cause incorrect operation.
  - When cleaning the camera lens, flush the camera with a large quantity of water and wipe it with a soft and wet cloth. Strongly rubbing the camera lens may cause the camera lens to be scratched and unable to transmit a clear image.
  - Do not allow an organic solvent, car wax, window cleaner or a glass coating to adhere to the camera. If this happens, wipe it off as soon as possible.
  - If the temperature changes rapidly, such as when hot water is poured on the vehicle in cold weather, the system may not operate normally.
  - When washing the vehicle, do not apply intensive bursts of water to the camera or camera area. Doing so may result in the camera malfunctioning.
- Do not expose the camera to strong impacts as this could cause a malfunction. If this happens, have the vehicle inspected by your Toyota retailer or Toyota authorized repairer, or any reliable repairer as soon as possible.

### Differences between the screen and the actual road

- The distance guide lines and the vehicle width guide lines may not actually be parallel with the dividing lines of the parking space, even when they appear to be so. Be sure to check visually.
- The distances between the vehicle width guide lines and the left and right dividing lines of the parking space may not be equal, even when they appear to be so. Be sure to check visually.
- The distance guide lines give a distance guide for flat road surfaces. In any of the following situations, there is a margin of error between the guide lines on the screen and the actual distance/course on the road.

#### ■ When the ground behind the vehicle slopes up sharply

The distance guide lines will appear to be closer to the vehicle than the actual distance. Because of this, objects will appear to be farther away than they actually are. In the same way, there will be a margin of error between the guide lines and the actual distance/course on the road.

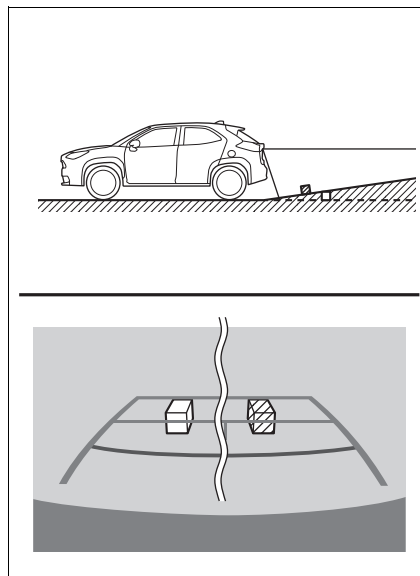

#### ■ When the ground behind the vehicle slopes down sharply

The distance guide lines will appear to be farther from the vehicle than the actual distance. Because of this, objects will appear to be closer than they actually are. In the same way, there will be a margin of error between the guide lines and the actual distance/course on the road.

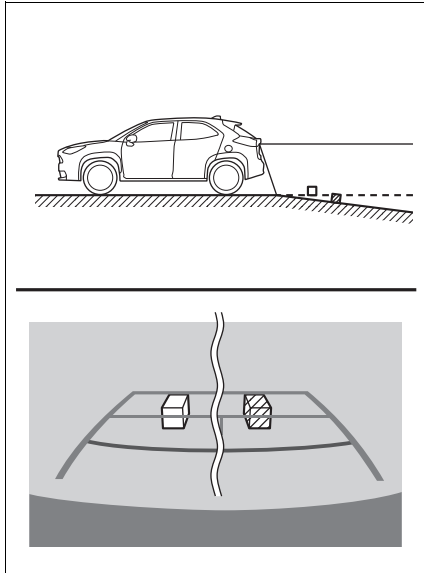

#### ■ When any part of the vehicle sags

When any part of the vehicle sags due to the number of passengers or the distribution of the load, there is a margin of error between the guide lines on the screen and the actual distance/course on the road.

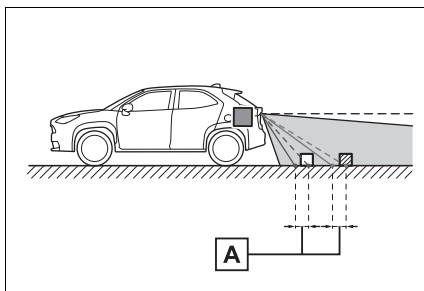

**A** A margin of error

#### When approaching three-dimensional objects

When there are three-dimensional objects (such as vehicle bumpers, etc.) nearby in positions higher than the surface of the road, take extra care when using the following.

#### ⚠ WARNING

- When a sensor indicator on the Toyota parking assist-sensor display illuminates in red or a buzzer sounds continuously, be sure to check the area around the vehicle immediately and do not proceed any further until safety has been ensured, otherwise an unexpected accident may occur.

#### Panoramic view display

Since the panoramic view and side clearance view process and display images based on flat road surfaces, it cannot depict the position of three-dimension objects (such as vehicle bumpers, etc.) that are in positions higher than the surface of the road. For example, even though it appears that there is space between the bumpers of the two vehicles in the illustration below and they are not likely to collide, in reality, a collision is about to occur.

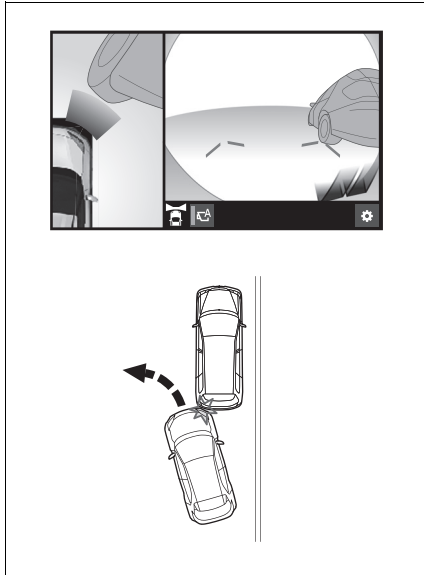

#### Estimated course lines

- Since the estimated course line is displayed for a flat road surface, it can not depict the position of three-dimensional objects (such as vehicle bumpers, etc.) that are in positions higher than the surface of the road. Even if the bumper of the vehicle is on the outside of the estimated course line in the image, in reality, the vehicles are on a collision course.

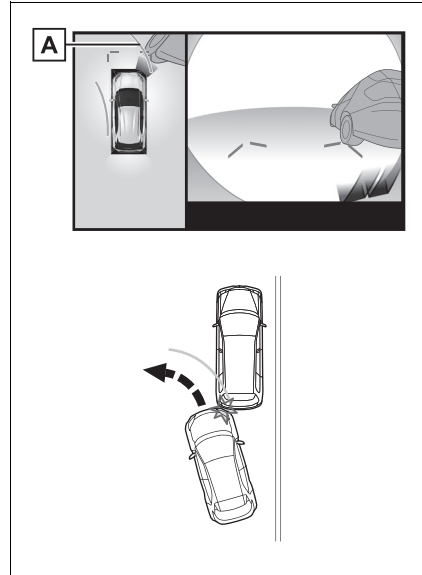

#### A Estimated course line

- Three-dimensional objects (such as the overhang of a wall or loading platform of a truck) in high positions may not be projected on the screen. Check the safety of the surroundings directly.

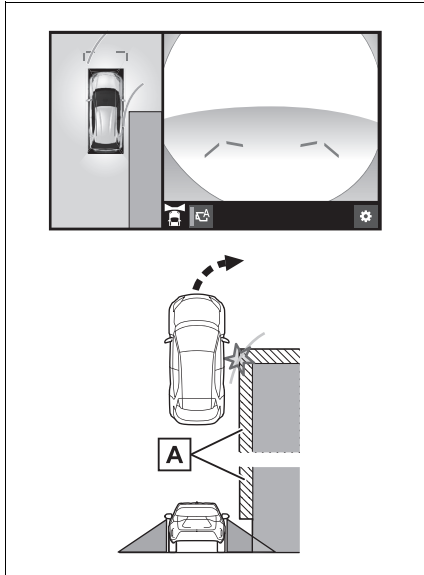

**A** The overhang of a wall

- Visually check the surroundings and the area behind the vehicle. In the case shown below, the truck appears to be outside of the estimated course lines and the vehicle does not look as if it hits the truck. However, the rear body of the truck may actually cross over the estimated course lines. In reality if you back up as guided by the estimated course lines, the vehicle may hit the truck.

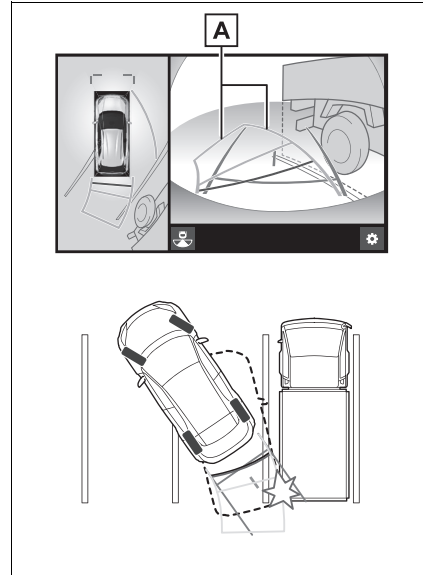

**A** Estimated course lines

#### Distance guide lines

Visually check the surroundings and the area behind the vehicle. On the screen, it appears that a truck is parking at point **B**. However, in reality if you back up to point **A**, you will hit the truck. On the screen, it appears that **A** is closest and **C** is farthest away. However, in reality, the distance to **A** and **C** is the same, and **B** is farther than **A** and **C**.

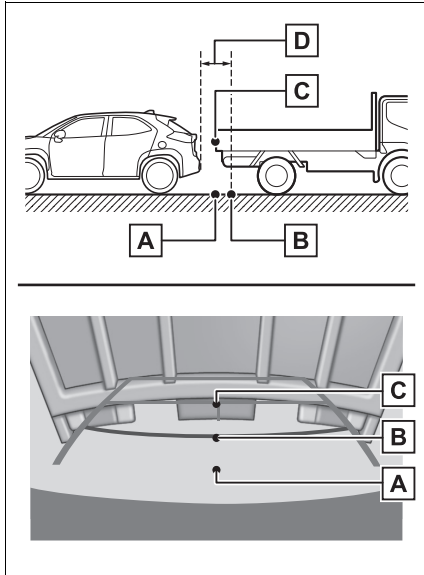

**D** Approx. 1 m (3 ft.)

**Things you should know**

**If you notice any symptoms**

If you notice any of the following symptoms, refer to the likely cause and the solution, and re-check.

If the symptom is not resolved by the solution, have the vehicle inspected by your Toyota retailer or Toyota authorized repairer, or any reliable repairer.

| Symptom                       | Likely cause  | Solution  |
|-------------------------------|---|---|
| The image is difficult to see | <ul style="list-style-type: none"> <li>• The vehicle is in a dark area</li> <li>• The temperature around the lens is either high or low</li> <li>• The outside temperature is low</li> <li>• There are water droplets on the camera</li> <li>• It is raining or humid</li> <li>• Foreign matter (mud etc.) is adhering to the camera</li> <li>• Sunlight or headlights are shining directly into the camera</li> <li>• The vehicle is under fluorescent lights, sodium lights, mercury lights etc.</li> </ul> | <p>Back up while visually checking the vehicle's surroundings.</p> <p>Use the monitor again once conditions have been improved.</p> <p>The procedure for adjusting the picture quality of the panoramic view monitor system is the same as the procedure for adjusting the navigation screen. (→P.31)</p> |
| The image is blurry           | <p>Dirt or foreign matter (such as water droplets, snow, mud etc.) is adhering to the camera.</p>   | <ul style="list-style-type: none"> <li>• Flush the camera with a large quantity of water and wipe the camera lens clean with a soft and wet cloth.</li> <li>• Operate the rear camera washer to clean the camera lens. For details, refer to "Owner's Manual".</li> </ul>                                 |

| Symptom  | Likely cause  | Solution  |
|--|---|---|
| The image is out of alignment  | The camera or surrounding area has received a strong impact.  | Have the vehicle inspected by your Toyota retailer or Toyota authorized repairer, or any reliable repairer.   |
| The guide lines are very far out of alignment  | The camera position is out of alignment.  | Have the vehicle inspected by your Toyota retailer or Toyota authorized repairer, or any reliable repairer.   |
|  | <ul style="list-style-type: none"> <li>The vehicle is tilted. (There is a heavy load on the vehicle, tire pressure is low due to a tire puncture, etc.)</li> <li>The vehicle is used on an incline.</li> </ul>  | If this happens due to these causes, it does not indicate a malfunction. Back up while visually checking the vehicle's surroundings.  |
| The estimated course lines move even though the steering wheel is straight                       | There is a malfunction in the signals being output by the steering sensor.  | Have the vehicle inspected by your Toyota retailer or Toyota authorized repairer, or any reliable repairer.   |
| Guide lines are not displayed  | The back door is open.  | Close the back door. If this does not resolve the symptom, have the vehicle inspected by your Toyota retailer or Toyota authorized repairer, or any reliable repairer.  |
|  is displayed | <ul style="list-style-type: none"> <li>12-volt battery has been reinstalled.</li> <li>The steering wheel has been moved while the 12-volt battery was being reinstalled.</li> <li>12-volt battery power is low.</li> <li>The steering sensor has been reinstalled.</li> <li>There is a malfunction in the signals being output by the steering sensor.</li> </ul> | <p>Stop the vehicle, and turn the steering wheel as far as it will go to the left and right.</p> <p>If this does not resolve the symptom, have the vehicle inspected by your Toyota retailer or Toyota authorized repairer, or any reliable repairer.</p> |

| Symptom  | Likely cause   | Solution   |
|--|--|--|
| The panoramic view display cannot be magnified                           | The Toyota parking assist-sensor may be malfunctioning or dirty. | Follow the correction procedures for malfunctions of the Toyota parking assist-sensor. (Refer to "Owner's Manual") |
| The see-through view/moving view/side clearance view cannot be displayed |  |  |

### Software license

This product uses free/open source software.

License information and/or the source code of this about free/open source software can be obtained at the following URL:

<https://www.denso-ten.com/support/source/oem/pvm/info-t2>

|   |            |
|---|------------|
| <b>7-1. Phone operation (Hands-free system for cellular phones)</b> |            |
| Quick reference .....   | <b>198</b> |
| Some basics .....   | <b>199</b> |
| Placing a call using the Bluetooth® hands-free system .....         | <b>203</b> |
| Receiving a call using the Bluetooth® hands-free system .....       | <b>207</b> |
| Talking on the Bluetooth® hands-free system .....                   | <b>207</b> |
| Bluetooth® phone message function .....                             | <b>209</b> |
| <b>7-2. Setup</b>   |            |
| Phone settings .....  | <b>214</b> |
| <b>7-3. What to do if...</b>  |            |
| Troubleshooting .....   | <b>223</b> |

For vehicles sold outside Europe, some of the functions cannot be operated while driving.

**Quick reference**

**Phone screen operation**

The phone top screen can be reached by the following methods:

- ▶ From the "PHONE" button
  - 1 Press the "PHONE" button.
- ▶ From the "MENU" button
  - 1 Press the "MENU" button, then select "Phone".

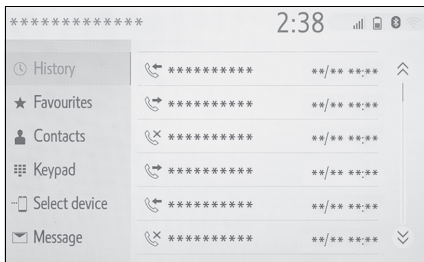

**Bluetooth® hands-free system operation**

The following functions can be used on phone operation:

- Registering/connecting a Bluetooth® device (→P.34)
- Placing a call using the Bluetooth® hands-free system (→P.203)
- Receiving a call using the Bluetooth® hands-free system (→P.207)
- Talking on the Bluetooth® hands-free system (→P.207)

**Message function**

The following function can be used on message function:

- Using the Bluetooth® phone message function (→P.209)

**Setting up a phone**

The following settings can be made in system:

- Phone settings (→P.214)
- Bluetooth® settings (→P.38)

### Some basics

**The hands-free system enables calls to be made and received without having to take your hands off the steering wheel.**

**This system supports Bluetooth®. Bluetooth® is a wireless data system that enables cellular phones to be used without being connected by a cable or placed in a cradle.**

**The operating procedure of the phone is explained here.**

**When an Apple CarPlay connection is established, phone functions will be performed by Apple CarPlay instead of the hands-free system.**

- This system is not guaranteed to operate with all Bluetooth® devices.
- If your cellular phone does not support Bluetooth®, this system cannot function.
- In the following conditions, the system may not function:
  - The cellular phone is turned off.
  - The current position is outside the communication area.
  - The cellular phone is not connected.
  - The cellular phone has a low battery.
- When using the hands-free system or Bluetooth® audio and Wi-Fi® functions at the same time, the following problems may occur:
  - The Bluetooth® connection may be cut.

- Noise may be heard on the Bluetooth® audio playback.
- A noise may be heard during phone calls.
- Bluetooth® uses the 2.4 GHz frequency band. If both a Wi-Fi® connection and Bluetooth® connection are being used simultaneously, each connection may be affected.
- If a Bluetooth® device is attempting to connect to the vehicle while another device is connected as a Bluetooth® audio device or connected using the hands-free system, Miracast® (via Wi-Fi®), the communication speed may decrease or malfunctions may occur, such as image distortion or audio skipping. If a Bluetooth® device is connected to the system, the interference it may cause will be reduced. When carrying a device with its Bluetooth® connection enabled, make sure to register it to the system and connect it or disable its Bluetooth® function.
- When a device is connected via Bluetooth®, the Bluetooth® icon on the status bar will be displayed in blue. (→P.16)

#### WARNING

- While driving, do not operate a cellular phone.
- Your audio unit is fitted with Bluetooth® antennas. People with implantable cardiac pacemakers, cardiac resynchronization therapy-pacemakers or implantable cardioverter defibrillators should maintain a reasonable distance between themselves and the Bluetooth® antennas. The radio waves may affect the operation of such devices.



**WARNING**

- Before using Bluetooth® devices, users of any electrical medical device other than implantable cardiac pacemakers, cardiac resynchronization therapy-pacemakers or implantable cardioverter defibrillators should consult the manufacturer of the device for information about its operation under the influence of radio waves. Radio waves could have unexpected effects on the operation of such medical devices.



**NOTICE**

- Do not leave your cellular phone in the vehicle. The temperature inside may rise to a level that could damage the phone.

**Registering/Connecting a Bluetooth® phone**

To use the hands-free system for cellular phones, it is necessary to register a cellular phone with the system. (→P.34)

■ **Connecting a Bluetooth® device**

- ▶ Registering an additional device
  - 1 Display the phone top screen. (→P.198)
  - 2 Select “Select device”.
  - 3 Select “Add device”.
- When another Bluetooth® device is connected, a confirmation screen will be displayed. To disconnect the Bluetooth® device,

select “Yes”.

- 4 Follow the steps in “Registering a Bluetooth® phone for the first time” from step 5. (→P.34)

▶ **Selecting a registered device**

- 1 Display the phone top screen. (→P.198)
  - 2 Select “Select device”.
  - 3 Select the desired device to be connected.
  - 4 Check that a confirmation screen is displayed when the connection is complete.
- If an error message is displayed, follow the guidance on the screen to try again.

■ **Bluetooth® phone condition display**

The condition of the Bluetooth® phone appears on the upper right side of the screen. (→P.16)

**Using the phone switch/microphone**

■ **Steering switch**

By pressing the phone switch, a call can be received or ended without taking your hands off the steering wheel.

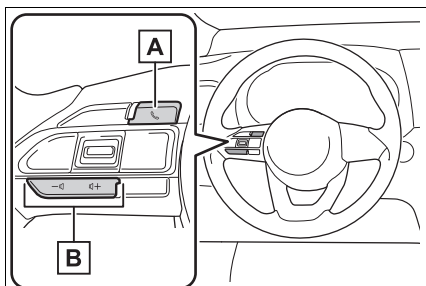
**A** Phone switch

- If the switch is pressed during a call, the call will end.
- If the switch is pressed when an incoming call is received, the call will be answered.
- If the switch is pressed during a call when a separate incoming call is waiting, the waiting call will be answered.
- If the switch is pressed when an Apple CarPlay connection is established, the Apple CarPlay phone application will be displayed on the system screen.

**B** Volume control switch

Press to adjust the volume.

**Microphone**

The microphone is used when talking on the phone.

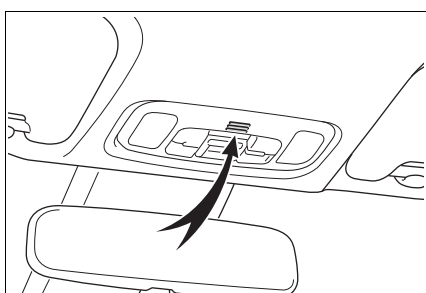

- The other party's voice will be heard from the front speakers. The

audio/visual system will be muted during phone calls or when hands-free speech commands are used.

- Talk alternately with the other party on the phone. If both parties speak at the same time, the other party may not hear what has been said. (This is not a malfunction.)
- Keep call volume down. Otherwise, the other party's voice may be audible outside the vehicle and voice echo may increase. When talking on the phone, speak clearly towards the microphone.
- The other party may not hear you clearly when:
  - Driving on an unpaved road. (Making excessive traffic noise.)
  - Driving at high speeds.
  - The windows are open.
  - The air conditioning vents are pointed towards the microphone.
  - The sound of the air conditioning fan is loud.
  - There is a negative effect on sound quality due to the phone and/or network being used.

**NOTICE**

- Do not touch and put a sharp object to the microphone. It may cause failure.

**Speech command system**

Press this switch to operate the speech command system.

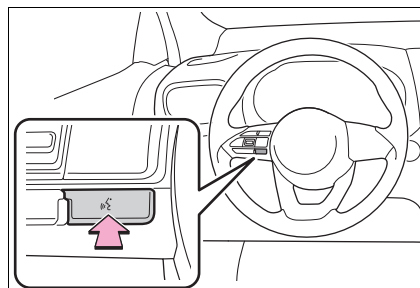

- The speech command system and its list of commands can be operated. (→P.148)

- Once initialized, the data and settings will be erased. Pay much attention when initializing the data.

### **About the contacts in the contact list**

- The following data is stored for every registered phone. When another phone is connected, the following registered data cannot be read:
  - Contact data
  - Call history data
  - Favourites data
  - Image data
  - All phone settings
  - Message settings

- When a phone's registration is deleted, the above-mentioned data is also deleted.

### **When selling or disposing of the vehicle**

A lot of personal data is registered when the hands-free system is used. When selling or disposing of the vehicle, initialize the data.

(→P.59)

- The following data in the system can be initialized:
  - Contact data
  - Call history data
  - Favourites data
  - Image data
  - All phone settings
  - Message settings

### Placing a call using the Bluetooth® hands-free system

After a Bluetooth® phone has been registered, a call can be made using the hands-free system. There are several methods by which a call can be made, as described below.

### Calling methods on the Bluetooth® phone

- 1 Display the phone top screen. (→P.198)
- 2 Select the desired method to call from.

#### ■ Calling methods from phone screen

- By call history (→P.203)
- By favourites (→P.204)
- By contacts (→P.204)
- By keypad (→P.205)
- By message (→P.212)

#### ■ Also the following lists are available from each function's screen

- By POI call\* (→P.74)
- By speech command system (→P.201)
- SOS\* (→P.205)
- By home screen (→P.206)

\*: Models with navigation function

### By call history

Up to 45 of the latest call history items (missed, incoming and outgoing) can be selected.

- 1 Display the phone top screen. (→P.198)
- 2 Select "History" and select the desired contact.
  - If the contact which is not registered on the contact list is selected, the name is displayed as "Unknown contact". In this case, select the number to make a call properly.
- 3 Check that the dialing screen is displayed.

- The icons of call type are displayed.

: Missed call

: Incoming call

: Outgoing call

- When making a call to the same number continuously, only the most recent call is listed in call history.
- When a phone number registered in the contact list is received, the name is displayed.
- Number-withheld calls are also memorized in the system.
- International phone calls may not be made depending on the type of Bluetooth® phone you have.
- The list should group together consecutive entries with the same phone number and same call type. For example, two calls from John's mobile would be displayed as follows: John (2)

**By favourites list**

Calls can be made using registered contacts which can be selected from a contact list. (→P.220)

- 1 Display the phone top screen. (→P.198)
- 2 Select “Favourites” and select the desired contact.
- 3 Select the desired number.
- 4 Check that the dialing screen is displayed.

**By contacts list**

Calls can be made by using contact data which is transferred from a registered cellular phone. (→P.216)

Up to 5000 contacts (maximum of 4 phone numbers and e-mail addresses per contact) can be registered in the contact list.

- 1 Display the phone top screen. (→P.198)
- 2 Select “Contacts” and select the desired contact.
- 3 Select the desired number.

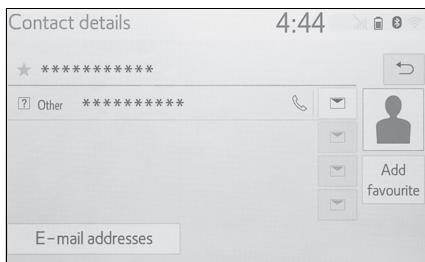

“Add favourite”/“Remove favourite”:  
Select to register/remove the contact in the favourites list. (→P.220, 221)

“E-mail addresses”: Select to display all registered e-mail addresses for the contact.

- 4 Check that the dialing screen is displayed.

**When the contact list is empty**

■ For PBAP compatible

**Bluetooth® phones when “Automatic transfer” is set to on (→P.217)**

- Contacts are transferred automatically.

■ For PBAP compatible

**Bluetooth® phones when “Automatic transfer” is set to off (→P.217)**

- 1 Select the desired item.

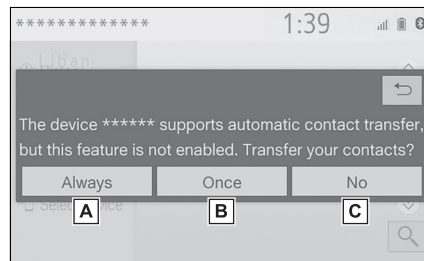

- A** Select to always transfer all the contacts from a connected cellular phone automatically.
- B** Select to transfer all the contacts from a connected cellular phone only once.
- C** Select to cancel transferring.

- 2 Check that a confirmation screen is displayed when the operation is complete.

■ **For PBAP incompatible but OPP compatible Bluetooth® phones**

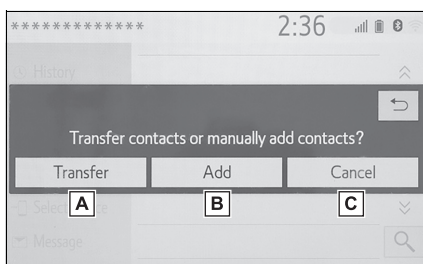

- 1 Select the desired item.



- A** Select to always transfer all the contacts from a connected cellular phone automatically.
- B** Select to add a new contact manually.  
Follow the steps in “Registering a new contact to the contacts list” from step 2. (→P.219)
- C** Select to cancel transferring.

- If your cellular phone is neither PBAP nor OPP compatible, the contacts cannot be transferred using Bluetooth®. But the contacts can be transferred from USB device. (→P.218)
- Depending on the type of Bluetooth® phone:
  - It may be necessary to perform additional steps on the phone when transferring contact data.
  - The registered image in the contact list may not transfer depending on the type of Bluetooth® phone connected.

### By keypad

- 1 Display the phone top screen. (→P.198)
- 2 Select “Keypad” and enter the phone number.
- 3 Select  or press the  switch on the steering wheel.
- 4 Check that the dialing screen is displayed.

- Depending on the type of Bluetooth® phone being connected, it may be necessary to perform additional steps on the phone.

### SOS\*

\*: Models with navigation function

### 112 emergency call support

This feature is used to make a 112 emergency call. This function is not available when the hands-free system is not connected.

The call has to be placed from a country where 112 is available.

- 1 Display the phone top screen. (→P.198)
  - 2 Select “Keypad” and select “SOS”.
  - 3 Select “112”.
  - 4 Check that the dialing screen is displayed.
- The current location of the vehicle is displayed on the screen.

### **Roadside assist**

This feature is used to make a call to Toyota roadside assist service.

The call has to be placed from a country where Toyota roadside assist service is available.

To use this function, it is necessary to register a country. (→P.222)

- 1** Display the phone top screen. (→P.198)
  - 2** Select “Favourites” and select “Toyota assistance”.
  - 3** Select .
  - 4** Check that the dialing screen is displayed.
- The current location of the vehicle is displayed on the screen.

- The contact cannot be registered at the home screen while driving.

### **By home screen**

- 1** Display the home screen. (→P.27)
- 2** Select the desired contact.
- 3** Check that the dialing screen is displayed.

### **Registering a new contact**

- 1** Select and hold the screen button to add a contact.
- 2** Select the desired contact.
- 3** Select the desired number.

- If there is no contact in the contacts list, the contacts cannot be registered at the home screen.

### Receiving a call using the Bluetooth® hands-free system

When a call is received, the following screen is displayed with a sound.

#### Incoming calls

- Select "Answer" or press the  switch on the steering wheel to talk on the phone.

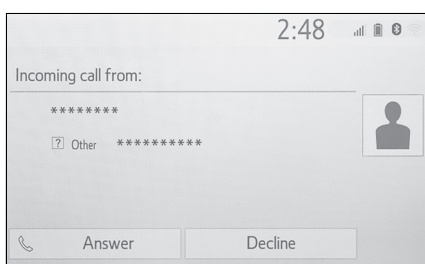

"Decline": Select to refuse to receive the call.

To adjust the volume of a received call: Turn the "POWER VOLUME" knob, or use the volume control switch on the steering wheel.

- During international phone calls, the other party's name or number may not be displayed correctly depending on the type of cellular phone you have.
- The incoming call display mode can be set. (→P.215)
- The ringtone that has been set in the sound settings screen can be heard when there is an incoming call. Depending on the type of Bluetooth® phone, both the system and Bluetooth® phone may ring simultaneously when there is an incoming call. (→P.214)

### Talking on the Bluetooth® hands-free system

While talking on the phone, the following screen is displayed. The operations outlined below can be performed on this screen.

#### Call screen operation

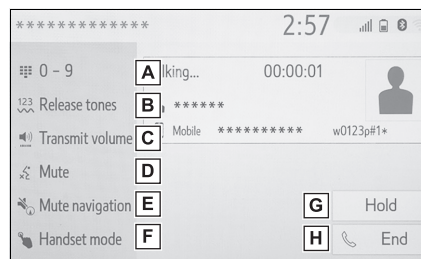

- Select to display the keypad to send tones. (→P.208)
- Select to send tones. This button only appears when a number that contains a (w) is dialed in hands-free mode. (→P.208)
- Select to adjust your voice volume that the other party hears from their speaker. (→P.208)
- Select to mute your voice to the other party.
- Select to mute the Navigation route guidance during a phone call.\*

**F** Select to change handset modes between hands-free and cellular phone.

**G** Select to put a call on hold. To cancel this function, select "Activate".

**H** Select to hang up the phone.

\*: Models with navigation function

- When cellular phone call is changed to hands-free call, the hands-free screen will be displayed and its functions can be operated on the screen.
- Changing between cellular phone call and hands-free call can be performed by operating the cellular phone directly.
- Transferring methods and operations will be different depending on the type of cellular phone you have.
- For the operation of the cellular phone, see the manual that comes with it.

### Sending tones

#### ■ By keypad

This operation cannot be performed while driving.

- 1 Select "0-9".
- 2 Enter the desired number.

#### ■ By selecting "Release tones"

"Release tones" appear when a continuous tone signal(s) containing a (w) is registered in the contact list.

This operation can be performed while driving.

- 1 Select "Release tones".

● A continuous tone signal is a character string that consists of numbers and the characters "p" or "w". (e.g. 056133w0123p#1)

● When the "p" pause tone is used, the tone data up until the next pause tone will be automatically sent after 2 seconds have elapsed. When the "w" pause tone is used, the tone data up until the next pause tone will be automatically sent after a user operation is performed.

● Release tones can be used when automated operation of a phone based service such as an answering machine or bank phone service is desired. A phone number with continuous tone signals can be registered in the contact list.

### Transmit volume setting

- 1 Select "Transmit volume".
- 2 Select the desired level for the transmit volume.
- 3 Press the  button to display previous screen.

● The sound quality of the voice heard from the other party's speaker may be negatively impacted.

● "Transmit volume" is dimmed when mute is on.

### Switching calls while a call is in progress

- When there are no calls on hold during a call: "Hold" is displayed. When selected, the current call is placed on hold.
- When there is no current call, but there is a call on hold: "Activate"

is displayed. When selected, the system switches to the call that was on hold.

- When there is another call on hold during a call: “Swap calls” is displayed. When selected, the current call is placed on hold, and the system switches to the call that was on hold.

- This function may not be available depending on the type of cellular phone.

### Incoming call waiting

When a call is interrupted by a third party while talking, the incoming call screen is displayed.

- 1 Select “Answer” or press the  switch on the steering wheel to start talking with the other party.

“Decline”: Select to refuse to receive the call.

### Changing parties

- 1 Select “Swap calls”.
- Each time “Swap calls” is selected during an interrupted call, the party who is on hold will be switched.

- This function may not be available depending on the type of cellular phone.

### Bluetooth® phone message function

Received messages can be forwarded from the connected Bluetooth® phone, enabling checking and replying using the system.

Depending on the type of Bluetooth® phone connected, received messages may not be transferred to the system.

If the phone does not support the message function, this function cannot be used.

### Displaying the message screen

- 1 Display the phone top screen. (→P.198)
- 2 Select “Message”.
- A confirmation message appears when the “Automatic message transfer” function is set to off (→P.221), select “Yes”.
- 3 Check that the message screen is displayed.

“Phone”: Select to change to phone mode.

- The account name is displayed on the left side of screen.
- Account names are the names of the accounts that exist on the currently connected phone.
- The following functions can be

used on message function:

- Receiving a message (→P.210)
- Checking received messages (→P.210)
- Checking sent messages (→P.211)
- Create new message (→P.211)
- Replying to a message (quick reply) (→P.212)
- Calling the message sender (→P.212)
- Message settings (→P.221)

### Receiving a message

When an e-mail/SMS/MMS is received, the incoming message screen pops up with sound and is ready to be operated on the screen.

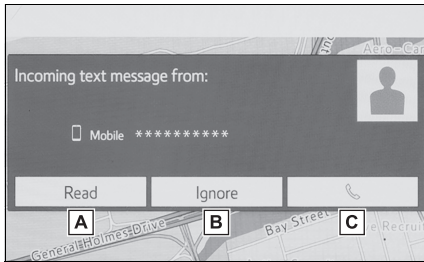

- A** Select to check the message.
- B** Select to not open the message.
- C** Select to call the message sender.

● Depending on the cellular phone used for receiving messages, or its registration status with the system, some information may not be displayed.

● The pop-up screen is separately available for incoming e-mail and SMS/MMS messages under the following conditions:

E-mail:

- “Incoming E-mail display” is set to “Full screen”. (→P.215)
- “E-mail notification pop-up” is set to on. (→P.215)

SMS/MMS:

- “Incoming SMS/MMS display” is set to “Full screen”. (→P.215)
- “SMS/MMS notification pop-up” is set to on. (→P.215)

### Checking received messages

- 1 Display the message screen. (→P.209)
- 2 Select a desired account name.
- 3 Select the desired message from the list.
- 4 Check that the message is displayed.

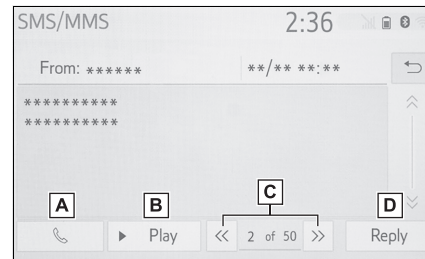

- A** Select to call the message sender.
- B** Select to have messages read out.

To cancel this function, select “Stop”.

When “Automatic message readout” is set to on, messages will be automatically read out.

(→P.221)

**C** Select to display the previous or next message.

**D** Select to reply the message.  
(→P.212)

- Depending on the type of Bluetooth® phone being connected, it may be necessary to perform additional steps on the phone.
- Messages are displayed in the appropriate connected Bluetooth® phone's registered mail address folder. Select the desired folder to be displayed.
- Only received messages on the connected Bluetooth® phone can be displayed.
- The text of the message is not displayed while driving.
- Turn the "POWER VOLUME" knob, or use the volume control switch on the steering wheel to adjust the message read out volume.
- "Subject:" field is not shown on SMS case.
- E-mail only: Select "Mark unread" or "Mark read" to mark mail unread or read on the message screen. This function is available when "Update message read status on phone" is set to on. (→P.221)

### Checking sent messages

- 1 Display the message screen.  
(→P.209)
- 2 Select the desired outbox from the list displayed on the left side of the screen.
- 3 Select the desired message from the list.

- 4 Check that the message is displayed.

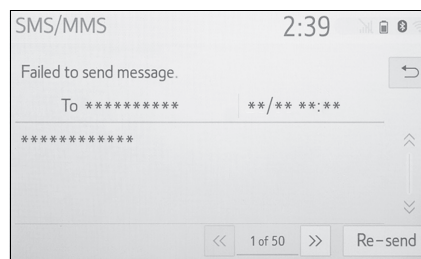

"Re-send": Select to re-send the message. This switch is displayed if sending the text message has failed.

### Create a new message

The message type which can be created is SMS only.

- 1 Display the phone top screen.  
(→P.198)
- ▶ From the contact or favourite screen
  - 2 Select "Contacts" or "Favourite".
  - 3 Select desired contact.
- ▶ From the call history screen
  - 2 Select "History".
  - 3 Select a contact not yet registered in the contact list.
- 4 Select  corresponding to the desired number.
- 5 Select "New".
- 6 Enter the message and then select "OK".
- 7 Select "Send".

"Cancel": Select to cancel sending the message.

- While the message is being sent,

a sending message screen is displayed.

- 8** Check that a confirmation screen is displayed when the operation is complete.
- If an error message is displayed, follow the guidance on the screen to try again.

- The short messages can contain up to 160 characters. The divided text will be sent when the message body exceed over 160 characters.
- Depending on the type of Bluetooth® phone used for receiving messages, reply function may not be used.

### Replying to a message (quick reply)

15 messages have already been stored.

- 1** Display the message screen. (→P.209)
- 2** Select a desired account name that is displayed on the left side of screen.
- 3** Select the desired message from the list.
- 4** Select “Reply”.
- 5** Select “Quick message”.
- 6** Select the desired message.

: Select to edit the message. (→P.212)

- 7** Select “Send”.

“Cancel”: Select to cancel sending the message.

- While the message is being sent,

a sending message screen is displayed.

- 8** Check that a confirmation screen is displayed when the operation is complete.
- If an error message is displayed, follow the guidance on the screen to try again.

- Depending on the type of Bluetooth® phone, reply function is not available.

### Editing quick reply messages

This operation cannot be performed while driving.

- 1** Select “Reply”.
- 2** Select “Quick message”.
- 3** Select  corresponding to the desired message to edit.
- 4** Select “OK” when editing is completed.

- To reset the edit quick reply messages, select “Default”.
  - Quick message 1 (“I am driving and will arrive in approximately [##] minutes.”)\*: This message cannot be edited and will automatically fill in [##] with the navigation calculated estimated time of arrival on the confirm message screen. If there are waypoints set, [##] to the next waypoint will be shown. If there is no route currently set in the navigation system, quick message 1 cannot be selected.
- \*: Models with navigation function



### Calling the message sender

Calls can be made to an e-

mail/SMS/MMS message sender's phone number.

This operation can be performed while driving.

#### ■ Calling from e-mail/SMS/MMS message display

- 1 Display the message screen. (→P.209)
- 2 Select a desired account name that is displayed on the left side of screen.
- 3 Select the desired message.
- 4 Select , or press the  switch on the steering wheel.
  - If there are 2 or more phone numbers, select the desired number.
- 5 Check that the dialing screen is displayed.

#### ■ Calling from a number within a message

Calls can be made to a number identified in a message's text area. This operation cannot be performed while driving.

- 1 Display the message screen. (→P.209)
- 2 Select a desired account name that is displayed on the left side of screen.
- 3 Select the desired message.

- 4 Select the text area.

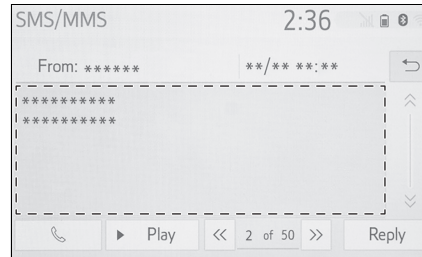

- Identified phone numbers contained in the message are displayed in blue text.
- 5 Select the desired number.
  - 6 Check that the dialing screen is displayed.
- A series of numbers may be recognized as a phone number. Additionally, some phone numbers may not be recognized, such as those for other countries.

#### ■ Calling from the incoming message screen

→P.210

**Phone settings**

**Displaying the phone settings screen**

- 1 Press the "SETUP" button.

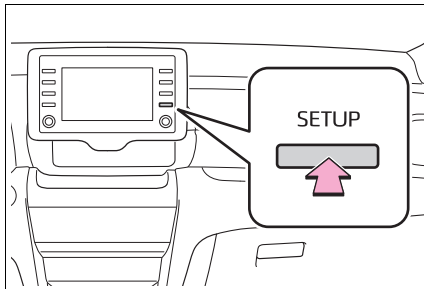

- 2 Select "Phone".
- 3 Select the desired item to be set.

**Phone settings screen**

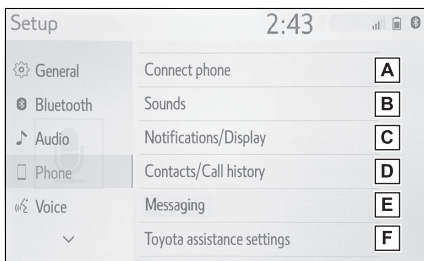

- A** Connecting a Bluetooth® device and editing the Bluetooth® device information (→P.39, 41)
- B** Sound settings (→P.214)
- C** Notification/display settings (→P.215)
- D** Contact/call history settings (→P.216)

**E** Message settings (→P.221)

**F** Toyota assistance settings\* (→P.222)

\*: Models with navigation function only

**Sounds settings screen**

The call and ringtone volume can be adjusted. A ringtone can be selected.

- 1 Display the phone settings screen. (→P.214)
- 2 Select "Sounds".
- 3 Select the desired item to be set.

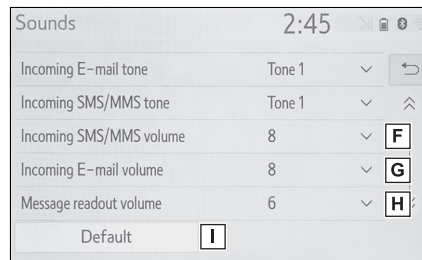
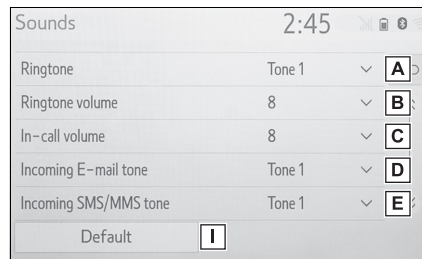

- A** Select to set the desired ringtone.
- B** Select "-" or "+" to adjust the ringtone volume.
- C** Select "-" or "+" to adjust the

default volume of the other party's voice.

- D** Select to set the desired incoming e-mail tone.
- E** Select to set the desired incoming SMS/MMS tone.
- F** Select “-” or “+” to adjust the incoming SMS/MMS tone volume.
- G** Select “-” or “+” to adjust the incoming e-mail tone volume.
- H** Select “-” or “+” to adjust the message readout volume.
- I** Select to reset all setup items.

- Depending on the type of phone, certain functions may not be available.

### Notifications/Display settings screen

- 1 Display the phone settings screen. (→P.214)
- 2 Select “Notifications/Display”.

- 3 Select the desired item to be set.

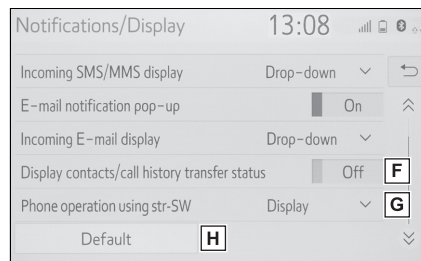
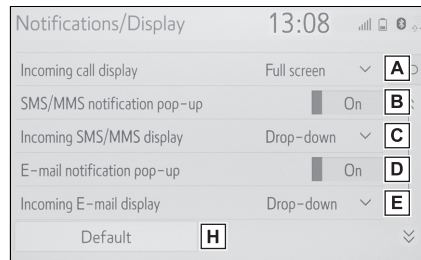

- A** Select to change the incoming call display.

“Full screen”: When a call is received, the incoming call screen is displayed and can be operated on the screen.

“Drop-down”: A message is displayed at the top of the screen.

- B** Select to set the SMS/MMS notification pop-up on/off.

- C** Select to change the incoming SMS/MMS display.

“Full screen”: When an SMS/MMS message is received, the incoming SMS/MMS display screen is displayed and can be operated on the screen.

“Drop-down”: When an SMS/MMS message is received, a message is displayed at the top of the screen.

- D** Select to set the e-mail notification pop-up on/off.

- E** Select to change the incoming e-mail display.

“Full screen”: When an e-mail is received, the incoming e-mail display screen is the displayed and can be operated on the screen.

“Drop-down”: When an e-mail is received, a message is displayed at the top of the screen.

- F** Select to set display of the contact/history transfer completion message on/off.

- G** The phone top screen can be set to be displayed on the multi-information display or system screen.

- H** Select to reset all setup items.

● Depending on the phone, these functions may not be available.

### Contact/Call history settings screen

Contacts can be transferred from a Bluetooth® phone to this system. Contacts and favourites can be added, edited and deleted. Also, the call history can be deleted.

- 1 Display the phone settings screen. (→P.214)
- 2 Select “Contacts/Call history”.

- 3 Select the desired item to be set.

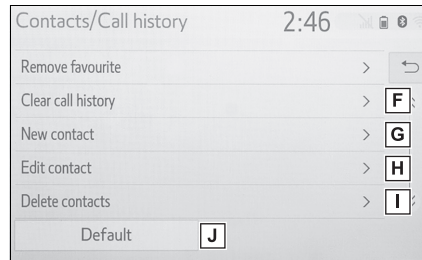
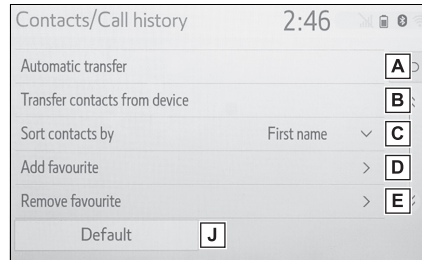

- A** For PBAP compatible

Bluetooth® phones: Select to change the contact/history transfer settings. (→P.217)

- B** Select to update contacts from the connected phone or a USB memory. (→P.218)

- C** Select to sort contacts by the first name or last name field.

- D** Select to add contacts to the favourites list. (→P.220)

- E** Select to delete contacts from the favourites list. (→P.220)

- F** Select to clear the call history.\*

- G** Select to add new contacts to the contact list.\* (→P.219)

- H** Select to edit contacts in the contact list.\* (→P.219)
- I** Select to delete contacts from the contact list.\* (→P.220)
- J** Select to reset all setup items.

\*: For PBAP compatible Bluetooth® phones, this function is available when “Automatic transfer” is set to off. (→P.217)

- Depending on the type of phone, certain functions may not be available.
- Contact data is managed independently for every registered phone. When one phone is connected, another phone’s registered data cannot be read.

#### Setting automatic contact/history transfer

The automatic contact/history function is available for PBAP compatible Bluetooth® phones only.

- 1** Select “Automatic transfer”.
- 2** Select the desired item to be set.

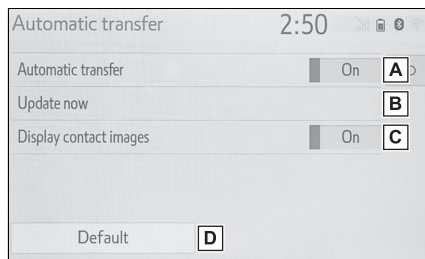

- A** Select to set automatic contact/history transfer on/off. When set to on, the phone’s

contact data and history are automatically transferred.

- B** Select to update contacts from the connected phone. (→P.217)
- C** Select to set the transferred contact image display on/off.
- D** Select to reset all setup items.

#### ■ Updating contacts from phone

- 1** Select “Update now”.
- Contacts are transferred automatically.
- 2** Check that a confirmation screen is displayed when the operation is complete.
- This operation may be unnecessary depending on the type of cellular phone.
  - If another Bluetooth® device is connected when transferring contact data, depending on the phone, the connected Bluetooth® device may need to be disconnected.
  - Depending on the type of Bluetooth® phone being connected, it may be necessary to perform additional steps on the phone.

#### ■ Updating the contacts in a different way (from the call history screen)\*

- 1** Display the phone top screen. (→P.198)

- 2 Select "History" and select a contact not yet registered in the contact list.
- 3 Select "Update contact".
- 4 Select the desired contact.
- 5 Select a phone type for the phone number.

\*: For PBAP compatible Bluetooth® phones, this function is available when "Automatic transfer" is set to off. (→P.217)

- When an Android Auto connection is established, this function will be unavailable.

#### **Transferring contacts from device**

##### **From phone (OPP compatible Bluetooth® phones only)**

- 1 Select "Transfer contacts from device".
- 2 Select "From phone (Bluetooth)".
  - ▶ When the contact is not registered
- 3 Transfer the contact data to the system using a Bluetooth® phone.
  - This operation may be unnecessary depending on the type of cellular phone.
  - To cancel this function, select "Cancel".

- 4 Check that a confirmation screen is displayed when the operation is complete.

▶ When the contact is registered

- 3 Select "Replace contacts" or "Add contact".

"Replace contacts": Select to transfer the contact from the connected cellular phone and replace the current one.

"Add contact": Select to transfer the desired contact data from the connected cellular phone to add to the current one.

- 4 Transfer the contact data to the system using a Bluetooth® phone.

- This operation may be unnecessary depending on the type of cellular phone.
- To cancel this function, select "Cancel".

- 5 Check that a confirmation screen is displayed when the operation is complete.

##### **From USB device**

Backed-up contact data ("vCard" formatted) can be transferred from USB device or Bluetooth® phone connected via USB to this system.

- 1 Connect a USB device. (→P.116)
- 2 Select "Transfer contacts from device".
- 3 Select "From USB".

**4** Select “USB 1” or “USB 2” when the multiple USB devices are connected.

- If a USB device is connected, skip this procedure.

- ▶ When the contact is not registered

**5** Select a desired file from vCard file list.

**6** Check that a confirmation screen is displayed when the operation is complete.

- ▶ When the contact is registered

**5** Select “Replace contacts” or “Add contact”.

“Replace contacts”: Select to transfer the contact from the connected USB device or Bluetooth® phone and replace the current one.

“Add contact”: Select to transfer the desired contact data from the connected USB device or Bluetooth® phone to add to the current one.

**6** Select a desired file from vCard file list.

**7** Check that a confirmation screen is displayed when the operation is complete.

- Depending type of phone used and number of files, it may take time to display vCard file lists and download contacts.

- Downloading may not complete correctly in the following cases:

- If the engine switch <power switch> is turned off during downloading.

- If the USB device or Bluetooth® phone is removed before downloading is complete.

### Registering a new contact to the contact list

New contact data can be registered.

Up to 4 numbers per person can be registered. For PBAP compatible Bluetooth® phones, this function is available when “Automatic transfer” is set to off. (→P.216)

- 1** Select “New contact”.
- 2** Enter the name and select “OK”.
- 3** Enter the phone number and select “OK”.
- 4** Select the phone type for the phone number.
- 5** To add another number to this contact, select “Yes”.

### Registering a new contact in a different way (from the call history screen)

- 1** Display the phone top screen. (→P.198)
- 2** Select “History” and select a contact not yet registered in the contact list.
- 3** Select “Add to contacts”.
- 4** Follow the steps in “Registering a new contact to the contact list” from step **2**. (→P.219)

### Editing the contact data

For PBAP compatible Bluetooth® phones, this function is available when “Automatic transfer” is set to

off. (→P.216)

- 1 Select "Edit contact".
- 2 Select the desired contact.
- 3 Select  corresponding to the desired name or number.
  - ▶ For editing the name
- 4 Follow the steps in "Registering a new contact to the contact list" from step 2. (→P.219)
  - ▶ For editing the number
- 4 Follow the steps in "Registering a new contact to the contact list" from step 3. (→P.219)

#### Deleting the contact data

For PBAP compatible Bluetooth® phones, this function is available when "Automatic transfer" is set to off. (→P.216)

- 1 Select "Delete contacts".
- 2 Select the desired contact and select "Delete".
- 3 Select "Yes" when the confirmation screen appears.

- Multiple data can be selected and deleted at the same time.
- When a Bluetooth® phone is deleted, the contact data will be deleted at the same time.

#### Favourites list setting

Up to 15 contacts (maximum of 4 numbers per contact) can be registered in the favourites list.

#### Registering the contacts in the favourites list

- 1 Select "Add favourite".
- 2 Select the desired contact to add to the favourites list.
  - Dimmed contacts are already stored as a favourites.
  - When 15 contacts have already been registered to the favourites list, a registered contact needs to be replaced. Select "Yes" when the confirmation screen appears and select the contact to be replaced.
- 3 Check that a confirmation screen is displayed when the operation is complete.

#### Registering contacts in the favourites list in a different way (from the contact details screen)

- 1 Display the phone top screen. (→P.198)
- 2 Select "Contacts" and select the desired contact.
- 3 Select "Add favourite".
- 4 Check that a confirmation screen is displayed when the operation is complete.

#### Deleting the contacts in the favourites list

- 1 Select "Remove favourite".
- 2 Select the desired contacts and select "Remove".

- 3 Select "Yes" when the confirmation screen appears.
  - 4 Check that a confirmation screen is displayed when the operation is complete.
- **Deleting contacts in the favourites list in a different way (from the contact details screen)**
- 1 Display the phone top screen. (→P.198)
  - 2 Select "Favourites" or "Contacts" and select the desired contact to delete.
  - 3 Select "Remove favourite".
  - 4 Select "Yes" when the confirmation screen appears.
  - 5 Check that a confirmation screen is displayed when the operation is complete.

- A** Select to set automatic message transfer on/off.
- B** Select to set automatic message readout on/off.
- C** Select to set updating message read status on phone on/off.
- D** Select to set display of messaging account names on the message screen on/off. When set to on, messaging account names used on the cellular phone will be displayed.
- E** Select to change the vehicle signature settings. (→P.221)
- F** Select to reset all setup items.

● Depending on the phone, these functions may not be available.

**Message settings screen**

- 1 Display the phone settings screen. (→P.214)
- 2 Select "Messaging".
- 3 Select the desired item to be set.

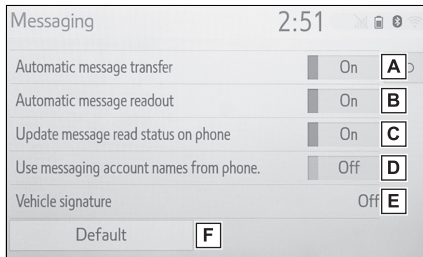

**Vehicle signature settings**

- 1 Select "Vehicle signature".
- 2 Select the desired item to be set.

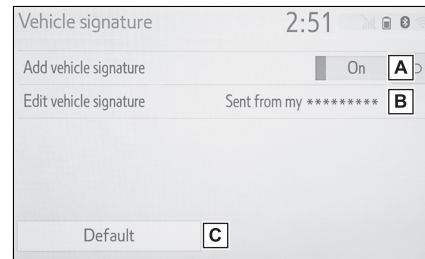

- A** Select to set adding the vehicle signature to outgoing messages on/off.

7  
Phone

**B** Select to edit the vehicle signature. (→P.222)

**C** Select to reset all setup items.

**■ Editing vehicle signature**

- 1 Select “Edit vehicle signature”.
- 2 Enter desired signature and select “OK”.
- 3 Select “OK” on the preview screen. “Edit again”: Select to edit the signature again.

**“Toyota assistance settings” screen\***

\*: Models with navigation function

**Registering a country**

- 1 Display the phone settings screen. (→P.214)
- 2 Select “Toyota assistance settings”.
- 3 Select the country.
- 4 Check that a confirmation screen is displayed when the operation is complete.

**Registering a country in a different way**

- 1 Display the phone top screen. (→P.198)
- 2 Select “Favourites”.
- 3 Select “Toyota assistance”.

4 Select the registered country's screen button.

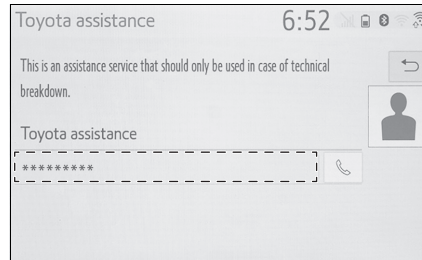

5 Select the country.

6 Select “Yes” when the confirmation screen appears.

**Troubleshooting**

If there is a problem with the hands-free system or a Bluetooth® device, first check the table below.

**Troubleshooting****When using the hands-free system with a Bluetooth® device**

The hands-free system or Bluetooth® device does not work.

- **The Bluetooth® version of the connected cellular phone may be older than the specified version.**

Use a cellular phone with Bluetooth® version 2.0 or higher (recommended: Ver. 4.2) (→P.37)

**When registering/connecting a cellular phone**

A cellular phone cannot be registered.

- **An incorrect passcode was entered on the cellular phone.**

Enter the correct passcode on the cellular phone.

- **The registration operation has not been completed on the cellular phone side.**

Complete the registration operation on the cellular phone (approve registration on the phone).

- **Old registration information remains on either this system or the cellular phone.**

Delete the existing registration information from both this system and the cellular phone, then register the cellular phone you wish to connect to this system. (→P.41)

**A Bluetooth® connection cannot be made.**

- **Another Bluetooth® device is already connected.**

Manually connect the cellular phone you wish to use to this system. (→P.39)

- **Bluetooth® function is not enabled on the cellular phone.**

Enable the Bluetooth® function on the cellular phone.

- **Automatic Bluetooth® connection on this system is set to off.**

Set automatic Bluetooth® connection on this system to on when the engine switch <power switch> is in ACC or ON. (→P.43)

■ **Preferred device settings function on this system is set to on.**

Set preferred device settings function on this system to off. (→P.43)

Set the desired cellular phone to the highest automatic connection priority. (→P.44)

**A cellular phone cannot be connected.**

■ **Bluetooth® function is not enabled on the cellular phone.**

Enable the Bluetooth® function on the cellular phone.

■ **Old registration information remains on either this system or the cellular phone.**

Delete the existing registration information from both this system and the cellular phone, then register the cellular phone you wish to connect to this system. (→P.41)

**When making/receiving a call**

**A call cannot be made/received.**

■ **Your vehicle is out of the service area.**

Move to where  no longer appears on the display.

**When using the phonebook**

**Phonebook data cannot be transferred manually/automatically.**

■ **Automatic contact transfer function on this system is set to off.**

Set automatic contact transfer function on this system to on. (→P.216)

■ **Passcode has not been entered on the cellular phone.**

Enter the passcode on the cellular phone if requested (default passcode: 1234).

■ **Transfer operation on the cellular phone has not completed.**

Complete transfer operation on the cellular phone (approve transfer operation on the phone).

**Phonebook data cannot be edited.**

■ **Automatic contact transfer function on this system is set to on.**

Set automatic contact transfer function on this system to off. (→P.216)

**When using the Bluetooth® message function****Messages cannot be viewed.**

- **Message transfer is not enabled on the cellular phone.**

Enable message transfer on the cellular phone (approve message transfer on the phone).

- **Automatic transfer function on this system is set to off.**

Set automatic transfer function on this system to on. (→P.216)

**New message notifications are not displayed.**

- **Notification of SMS/MMS/E-mail reception on this system is set to off.**

Set notification of SMS/MMS/E-mail reception on this system to on. (→P.215)

- **Automatic message transfer function is not enabled on the cellular phone.**

Enable automatic transfer function on the cellular phone.

**In other situations**

**The Bluetooth® connection status is displayed at the top of the screen each time the system is activated.\***

- **Connection confirmation display on this system is set to on.**

To turn off the display, set connection confirmation display on this system to off. (→P.43)

\*: The engine switch <power switch> is in ACC or ON.

**Even though all conceivable measures have been taken, the symptom status does not change.**

- **The cellular phone is not close enough to this system.**

Bring the cellular phone closer to this system.

- **Radio interference has occurred.**

Turn off Wi-Fi® devices or other devices that may emit radio waves.

- **The cellular phone is the most likely cause of the symptom.**

Turn the cellular phone off, remove and reinstall the battery pack, and then restart the cellular phone.

Enable the cellular phone's Bluetooth® connection.

Disable the Wi-Fi® connection of the cellular phone.

Stop the cellular phone's security software and close all applications.

Before using an application installed on the cellular phone, carefully check its source and how its operation might affect this system.

- 
- For details, refer to the owner's manual that came with the cellular phone.

## Toyota online

## 8

**8-1. Toyota online**

Toyota online .....228

Settings required for using the  
service .....231Toyota online applications  
operation .....232

Online search .....233

Importing favourites and stored  
routes .....233

Street View .....235

Weather .....235

Parking .....236

Fuel price .....237

**8-2. Setup**

Online settings .....239

Not all connected services may be available in all countries.

### Toyota online\*

\*: Models with navigation function (This function is not available in some countries or areas.)

The following services are available by connecting the system to Toyota portal site via the internet using a cellular phone or Wi-Fi® network.

- Online search: New establishments, such as restaurants, bars etc., that are not registered in the system, can be set as a destination.
- Importing favourites and routes: Establishments that were searched using a personal computer can be set as a destination and can be registered as favourites.
- Street View: The Street View of the desired location can be viewed.
- Weather: Weather information for a desired location can be displayed.
- Fuel price: Fuel price information for a desired location can be displayed.
- Parking: Parking availability and price for a desired location can be displayed.
- Remote customisation: Remote customisation allows users to set their preferred vehicle settings from Toyota Portal site.

### System components

► Online search/Street View/Weather/Fuel price/Parking

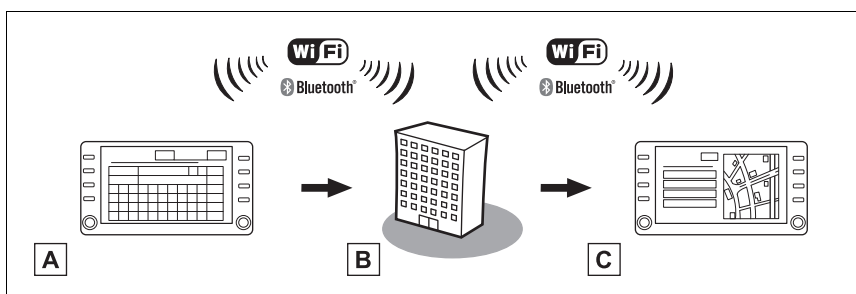

The Wi-Fi CERTIFIED™ Logo is a certification mark of the Wi-Fi Alliance®.

**A** System

Enter a keyword.

**B** Toyota portal site/Contents provider

The keyword is sent to the search engine, the results are received, and sent to the system.

**C** System

The results are displayed.

► Importing favourites and routes: Downloading via the internet

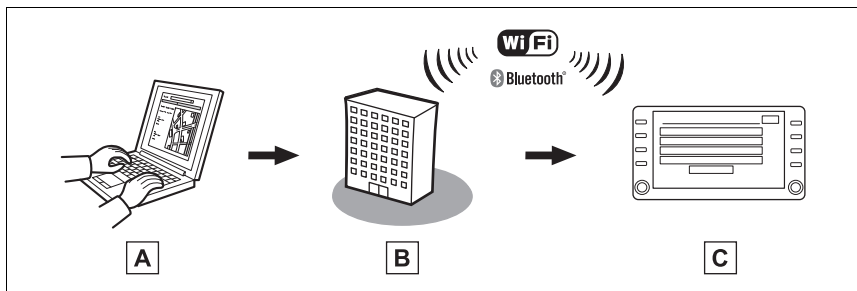

The Wi-Fi CERTIFIED™ Logo is a certification mark of the Wi-Fi Alliance®.

**A** Your personal computer and Toyota portal site

Access Toyota portal site and search POIs and routes.

**B** Toyota portal site

The POIs and routes are saved on Toyota portal site.

**C** System

Via the internet, the POIs and routes are downloaded to the system.

► Importing favourites and routes: Downloading from a USB memory

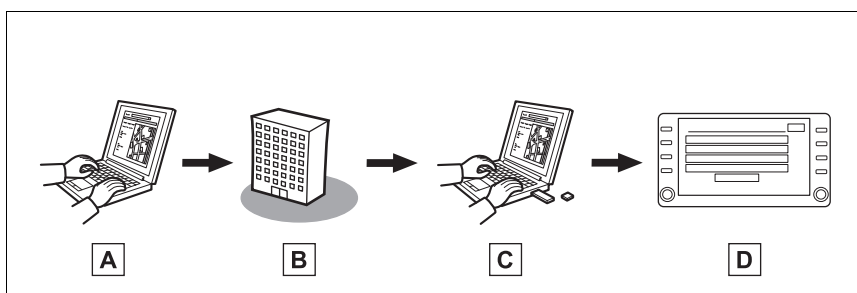

**A** Your personal computer and Toyota portal site

Access Toyota portal site and search POIs and routes.

**B** Toyota portal site

The POIs and routes are saved on Toyota portal site.

**C** USB memory

The POIs and routes are saved to the USB memory.

**D** System

Via the USB memory, the POIs and routes are downloaded to the system.

---

● For details about Toyota portal site, refer to [www.my.toyota.eu](http://www.my.toyota.eu).

### **Before using Toyota online**

Before using Toyota online service, it is necessary to create an account. There are 2 methods to make a new account.

- Obtaining an account via Toyota Portal site. (→P.231)
- Obtaining an account via the system. (→P.231)

When using a cellular phone to connect to the internet, observe the following precautions:

- In order to use this service, a Wi-Fi® connection or Bluetooth® PAN compatible cellular phone with sufficient network coverage and a SIM card with a contract that allows access to the internet are required.
- When using the Toyota online, depending on your phone subscription, some related fees might apply.
- When a cellular phone is used in a roaming situation (when outside the geographical coverage area of mobile network provider) connection fees may apply.

### Settings required for using the service

#### Obtaining Toyota portal site account

Before using Toyota online service, it is necessary to create an account. There are 2 methods to make a new account. When using some Toyota online applications, an internet connection is required.

#### Obtaining an account via Toyota Portal site

Before using Toyota online, access Toyota portal site ([www.my.toyota.eu](http://www.my.toyota.eu)) via a personal computer etc. and create an account.

After that, perform the following procedure on the navigation system.

- 1 Press the "SETUP" button.

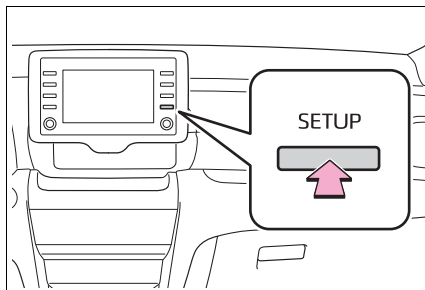

- 2 Select "Online".
- 3 Select "Toyota online".
- 4 Select "Existing account".
- 5 Input required information.

#### Obtaining an account via the system

- 1 Press the "SETUP" button.
- 2 Select "Online".
- 3 Select "Toyota online".
- 4 Select "New account".
- 5 Input required information.

#### Connecting to internet

The system must be connected to the internet to use this service.

- Via a Bluetooth® device (→P.34)
- Via Wi-Fi® (→P.45)

**Toyota online applications operation**

it is necessary set the preferred service to "Toyota online". (→P.59)

**Toyota online applications screen**

Toyota online applications screen can be reached by the following methods:

- 1 Press the "MENU" button.

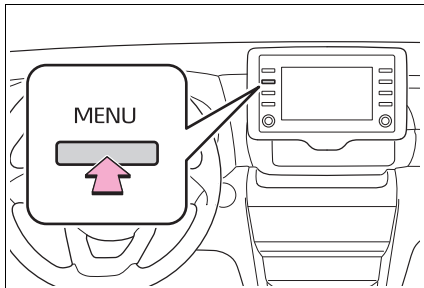

- 2 Select "Apps".
- 3 Select the desired application.

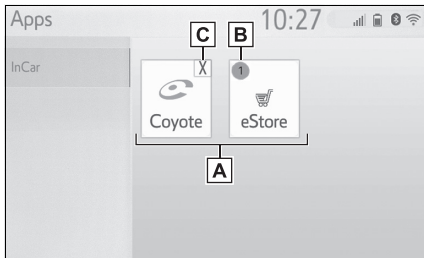

- A** Start the selected application.
- B** Displays notifications that there are some changes or updates for the application.
- C** Select to close running applications.

● To use the Toyota online applications,

**Online search**

**New establishments or establishments that are not registered in the system can be set as a destination.**

**In order to perform an online search, the system must already be connected to the internet. (→P.231)**

**The followings are the online search related functions.**

- Search box: →P.78
- POI search: →P.83
- POI details: →P.85

**Importing favourites and stored routes**

**POIs and routes searched on Toyota portal site can be downloaded to the system and saved as favourites.**

**There are 2 methods to download POIs and routes to the system:**

**(a) After saving the POIs and routes on Toyota portal site, they can be downloaded via the internet.**

**(b) After saving the POIs and routes on Toyota portal site, download them to a USB memory. The POIs and routes can then be downloaded via the USB memory.**

**When downloading POIs and routes to the system, both procedures are performed in the vehicle.**

**For details about POI and route searches on Toyota portal site and downloading POIs and routes to a USB memory, refer to [www.my.toyota.eu](http://www.my.toyota.eu).**

**Registering an external point as a favourite and routes from the internet**

To access Toyota portal site via the internet, the cellular phone or Wi-Fi® must already be registered with

the system. (→P.231)

- 1 Press the "SETUP" button.

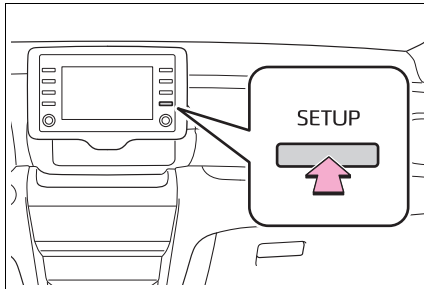

- 2 Select "Online".
  - 3 Select "Toyota online".
  - 4 Select "Load POIs and routes from server".
  - 5 Check that a confirmation screen is displayed when the operation is complete.
- To edit favourites and routes: →P.100

- 
- Setting "POI Auto Download" to On will automatically download external points. (→P.240)
  - Even if there is same name of favourite, it will be displayed on the list without overwrite.

### Procedure for downloading favourites and routes from a USB memory

- 1 Connect a device to the USB port.

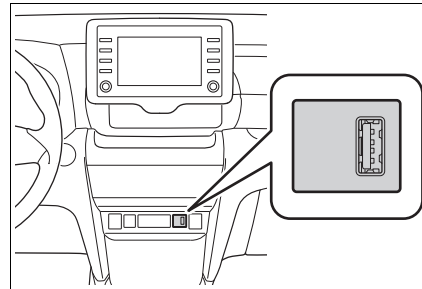

- 2 Select "Yes" on the popup which tells "Your USB device contains POIs and/or routes. Add these to the navigation favourites?"
  - 3 Waiting the process.
  - 4 Complete screen will be displayed.
- All routes and favourites are copied.

- 
- Favourites that are located outside of the map's data range cannot be registered.
  - A maximum of 200 favourites can be registered.
  - In some cases, favourites and routes may not be able to be imported. If this occurs, an error message with more details will be displayed.

## Street View

The Street View of the desired location can be viewed, provided the system is connected to the internet. (→P.231)

### Displaying the Street View

Street View can be activated whenever the Street View icon is visible.

- 1 Press the "MAP" button.

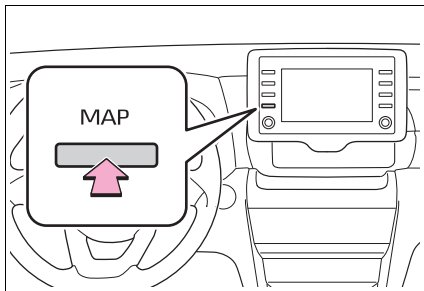

- 2 Select a point on the map.
- 3 Select .
- 4 Check that the picture is displayed.

"<", ">": Select to change pictures. Up to 6 pictures per location can be displayed.

- The Street View function can also be selected from the following screens:
  - Route overview screen (→P.87)
  - Online POI details screen (except traffic messages) (→P.74)
- This function is not available while driving.

## Weather

Weather information for a desired location can be displayed, provided the system is connected to the internet. (→P.231)

### Displaying the weather screen

- 1 Press the "MAP" button.

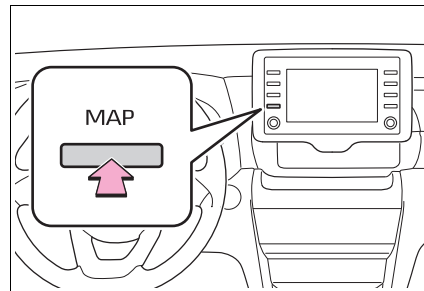

- 2 Select  on the map screen.
- 3 Select "Weather".
- 4 Check that the weather screen is displayed.

"Location": Select to change the location of weather information. (→P.235)

"Forecast": Select to display the weather forecast for the next 5 days.

"Current": Select to display the weather for current time.

: Select to update the weather information.

### Changing location

- 1 Display the weather screen. (→P.235)

- 2 Select "Location".
- 3 Select the desired item to search for a point.

"At destination": Select to set a location by using a current destination.

"Current location": Select to set a location by using the current position.

"Search location": Select to search for another location.

"Set location": Select to set a new favourite location. (→P.236)

■ **Registering favourites**

- 1 Select "Set location".
- 2 Enter desired location by performing search. Select the desired location from the search results.

● Up to 20 locations can be registered.

**Parking**

**Parking information for a desired location can be displayed, provided the system is connected to the internet.**

(→P.231)

**Displaying the Parking list screen**

- 1 Press the "MAP" button.

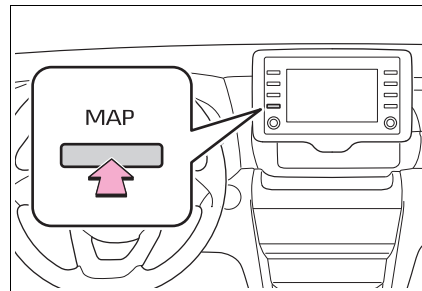

- 2 Select  on the map screen.
- 3 Select "Parking".
- 4 POI list with parking will be displayed. (if there is any information on offline or online database.)

: Select to sort by distance.

: Select to sort alphabetically by POI name.

: Select to sort by price.\*

\*: This function needs an Internet connection and a login on the Toyota server.

: Select to display the list with map.

: Select to update parking information.

**5** Check that the parking information is displayed.

“Go”: Select to display the starting route guidance screen. (→P.87)

“Call”: Select to call the registered phone number. (→P.207)

: Select to display the Street View. (→P.235)

### Changing location

**1** Display the parking screen. (→P.236)

**2** Select search area.

“Nearby”: Select to sort by around current location.

“Destination”: Select to sort by around destination.\*

“On route”: Select to sort by around current route.\*

\*: Only available if destination is set.

### Fuel price

**Fuel price information for a desired location can be displayed, provided the system is connected to the internet. (→P.231)**

### Displaying the fuel price list screen

**1** Press the “MAP” button.

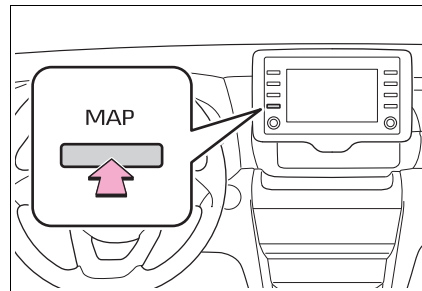



**2** Select  on the map screen.

**3** Select “Fuel”.

**4** POI list with fuel prices will be displayed. (if there is any information on offline or online database.)

: Select to sort by distance.

: Select to sort by brand.

: Select to sort by price.\*

\*: This function needs an Internet connection and a login on the Toyota server.

: Select to display the list with map.

: Select to update fuel price information.

tion.

- 5** Check that the fuel price information is displayed.

“Go”: Select to display the starting route guidance screen. (→P.87)

“Call”: Select to call the registered phone number. (→P.207)

 : Select to display the Street View. (→P.235)

### **Changing location**

- 1** Display the fuel price screen. (→P.237)

- 2** Select search area.

“Nearby”: Select to sort by around current location.

“Destination”: Select to sort by around destination.\*

“On route”: Select to sort by around current route.\*

\*: Only available if destination is set.

**Online settings**

The following detailed online settings can be set.

**Displaying online settings screen**

- 1 Press the "SETUP" button.

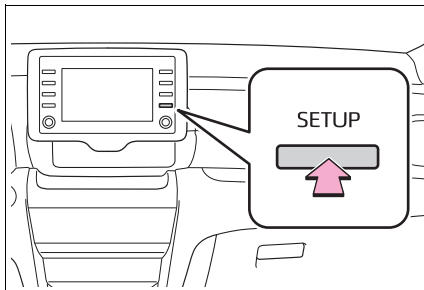

- 2 Select "Online".
- 3 Select the items to be set.

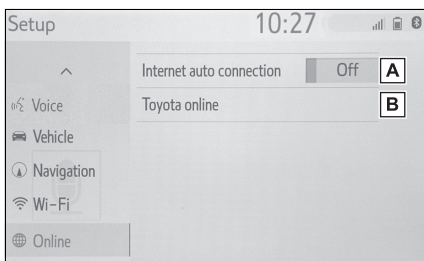

- A** Select to activate/deactivate internet auto connection for traffic information over Internet and auto-starting apps which need an Internet connection.
- B** Select to set detailed Toyota online settings.

**Toyota online settings**

- 1 Display the online settings screen. (→P.239)
- 2 Select "Toyota online".
- 3 Select the items to be set.

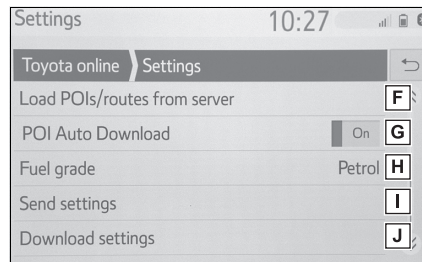
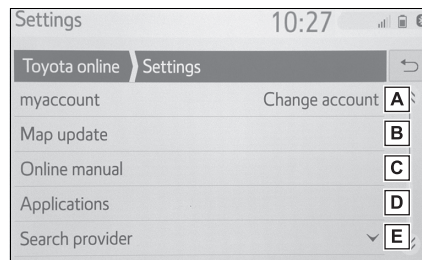

- A** Shows the account name logging in. Select to create a new account or log in with an existing account. (→P.240)
- B** Select to display the map update information. (→P.240)
- C** Select to display the QR code to access the online setting manual. (→P.241)
- D** Select to set detailed respective application settings. (→P.241)
- E** Select to set the desired search provider. (→P.241)

8  
Toyota online



- F** Select to add POIs and routes by downloading from the Toyota portal site. They will be stored in the favourites list.
- G** Select to switch to automatically download POIs and routes from the server.
- H** Select to set the fuel type. (→P.242)
- I** Select to upload settings from the navigation system to the Toyota server.
- J** Select to download settings from the Toyota server to the navigation system.

**Account settings**

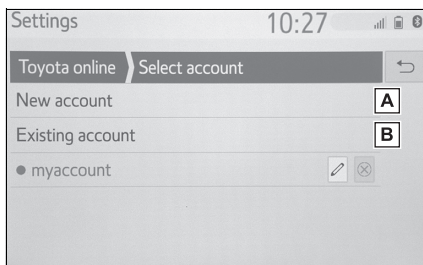
- 1 Display the Toyota online settings screen. (→P.239)
- 2 Select “Change account”.
- 3 Select the items to be set.



- A** Select to set the new account.
- B** Select to login to an existing account. If the account already has been created previously,

select the desired account name below. Select  or  to edit/delete the existing account.

**Map update information and settings**

- 1 Display the Toyota online settings screen. (→P.239)
- 2 Select “Map update”.
- 3 Confirm and change the map update settings.

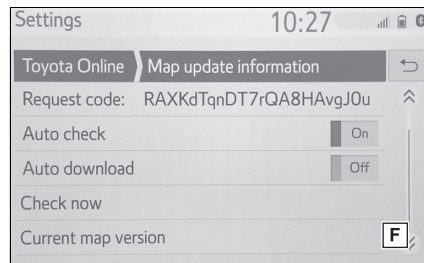
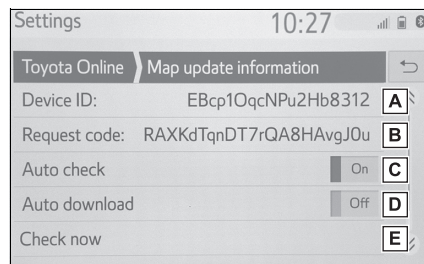

- A** Device ID is unique to the device and cannot be changed.
- B** Displays the request code to manually add device on Toyota portal.
- C** Select to set the system to automatically check if a map update is available.

- D** Select to set the system to automatically download the update if a map update is available.
- E** Select to manually check if a map update is available.
- F** Select to show the current map version.

### Online manual

You can get tips for using this system via QR code or URL.

- 1 Display the Toyota online settings screen. (→P.239)
- 2 Select “Online manual”.
- 3 Scan the QR code on your phone or access to the URL displayed on the screen.

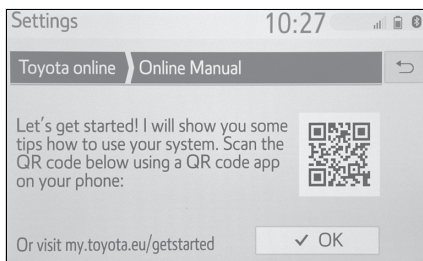

- Get Started wizard will be launched.

### Application settings

- 1 Display the Toyota online settings screen. (→P.239)
- 2 Select “Applications”.

- 3 Select the items to be set.

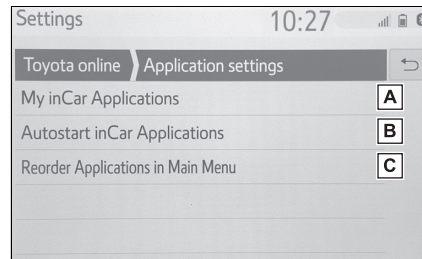

- A** Select to list up all applications which are downloaded on the system. Select  to delete the application. Selecting an application displays the application Information screen with a button on it, which allows removing/stopping the respective application.
- B** Select to choose which application shall auto-start after the system is started.
- C** Select to change the order of application contents. Drag the desired application to the desired position in the list.

### Search engine setting

The desired search engine can be set. Before using a new search engine, the terms of use must be read and agreed to on Toyota portal site. Depending on the conditions, certain search engines cannot be selected.

- 1 Display the Toyota online settings screen. (→P.239)
- 2 Select “Search provider”.
- 3 Select the desired search engine.

#### **Fuel grade settings**

It is possible to change the preferred fuel grade used for price information.

- 1 Display the Toyota online settings screen. (→P.239)
- 2 Select “Fuel grade”.
- 3 Select the desired fuel grade.

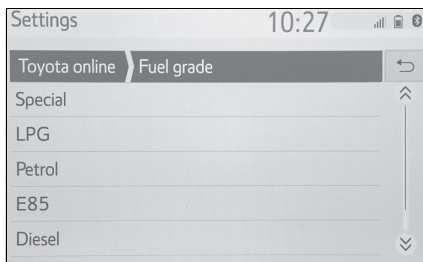

**Index**

**243**

Alphabetical Index .....**244**

## Alphabetical Index

### A

|   |         |
|---|---------|
| <b>AM</b> .....                                     | 120     |
| <b>Android Auto</b> .....                           | 50, 130 |
| <b>“Android Auto” button (“Menu” screen)</b> .....  | 15, 50  |
| <b>Apple CarPlay</b> .....                          | 50      |
| <b>“Apple CarPlay” button (“Menu” screen)</b> ..... | 15, 50  |
| <b>“Apps” button (“Menu” screen)</b> .....          | 15      |
| <b>Audio</b>  |         |
| Audio source .....                                  | 115     |
| Operating information .....                         | 139     |
| Reordering the audio source .....                   | 116     |
| Screen adjustment .....                             | 117     |
| Some basics .....                                   | 115     |
| Sound settings .....                                | 116     |
| Speech command system .....                         | 119     |
| Turning the system on and off .....                 | 115     |
| USB port .....                                      | 116     |
| <b>“Audio” button (“Menu” screen)</b> .....         | 15      |
| <b>“Audio” button (“Setup” screen)</b> .....        | 18      |
| <b>“AUDIO” button</b> .....                         | 114     |
| <b>Audio settings</b> .....                         | 138     |
| Common settings .....                               | 138     |
| <b>Audio source</b> .....                           | 115     |

### B

|  |     |
|--|-----|
| <b>Bluetooth® audio</b> .....                    | 131 |
| Registering/Connecting a Bluetooth® device ..... | 133 |
| <b>“Bluetooth” button (“Setup” screen)</b> ..... | 18  |
| <b>Bluetooth® details settings</b> .....         | 38  |
| Bluetooth® setup screen .....                    | 38  |
| Connecting a Bluetooth® device .....             | 39  |
| Deleting a Bluetooth® device .....               | 41  |
| “Detailed settings” screen .....                 | 43  |
| Displaying the Bluetooth® setup screen .....     | 38  |
| Editing the Bluetooth® device information .....  | 41  |
| Registering a Bluetooth® device .....            | 41  |
| <b>Bluetooth® device information</b> .....       | 41  |
| <b>Bluetooth® hands-free system</b> .....        | 198 |
| <b>Bluetooth® phone message function</b> .....   | 209 |
| Calling the message sender .....                 | 212 |
| Checking received messages .....                 | 210 |
| Checking sent messages .....                     | 211 |
| Create new message .....                         | 211 |
| Displaying the message screen .....              | 209 |
| Receiving a message .....                        | 210 |
| Replying to a message (quick reply) .....        | 212 |

| <b>C</b>   |            |
|--|------------|
| <b>Clock settings</b> .....                              | <b>58</b>  |
| <b>Command list</b> .....                                | <b>150</b> |
| <b>Connecting to internet/Miracast® via Wi-Fi®</b> ..... | <b>45</b>  |
| Displaying the Wi-Fi® settings screen .....              | 45         |
| Operating hints .....                                    | 48         |
| Wi-Fi® settings screen .....                             | 45         |

| <b>D</b>                                |            |
|---|------------|
| <b>DAB</b> .....                        | <b>120</b> |
| <b>“Display” button (“Menu” screen)</b> | <b>15</b>  |

| <b>E</b>  |            |
|---|------------|
| <b>Editing route</b> .....                                      | <b>93</b>  |
| Blocking road segments .....                                    | 95         |
| Deleting stopovers and destination .....                        | 95         |
| Detour setting .....  | 96         |
| Displaying destination information .....                        | 94         |
| Displaying the edit route screen .....                          | 93         |
| Displaying the turn list .....                                  | 95         |
| Dynamic rerouting by the traffic messages .....                 | 96         |
| Reordering stopovers .....                                      | 94         |
| <b>Editing the entry information</b> .....                      | <b>100</b> |
| <b>Entering letters and numbers/list screen operation</b> ..... | <b>28</b>  |
| Entering letters and numbers .....                              | 28         |
| List screen .....   | 30         |

| <b>F</b>                                    |            |
|---|------------|
| <b>FM</b> .....                             | <b>120</b> |
| <b>Fuel price</b> .....                     | <b>237</b> |
| Displaying the fuel price list screen ..... | 237        |

| <b>G</b>                                       |               |
|--|---------------|
| <b>“General” button (“Setup” screen)</b> ..... | <b>18, 57</b> |
| <b>General settings</b> .....                  | <b>57</b>     |
| Displaying the general settings screen .....   | 57            |
| General settings screen .....                  | 57            |
| <b>GPS (Global Positioning System)</b>         | <b>109</b>    |
| Limitations of the navigation system .....     | 109           |
| <b>Guiding the route</b> .....                 | <b>20</b>     |
| Deleting destinations .....                    | 21            |
| Setting the destination .....                  | 20            |

| <b>H</b>                           |            |
|------------------------------------|------------|
| <b>Hands-free system</b> .....     | <b>198</b> |
| <b>Home screen operation</b> ..... | <b>27</b>  |

I

**Importing favourites and stored routes** ..... 233  
 Procedure for downloading favourites and routes from a USB memory ..... 234  
 Registering an external point as a favourite and routes from the internet ..... 233  
**Initial screen** ..... 24  
 Caution screen ..... 24  
 Restarting the system ..... 24  
**iPod/iPhone** ..... 127

L

**Linking multi-information display and the system** ..... 33

M

**“Map” button (“Menu” screen)** 15, 64  
**Map screen information** ..... 71  
 Displaying POI information ..... 74  
 Displaying various information on the map ..... 71  
 POI icons ..... 72  
**Map screen operation** ..... 19, 69  
 Current position display ..... 19, 69  
 Map layout ..... 70  
 Map scale ..... 19, 69  
 Screen scroll operation ..... 19, 69

**Map settings** ..... 102  
 Displaying map setting screen ... 102  
**“MENU” button** ..... 15  
**“Menu” screen** ..... 15  
 Menu screen operation ..... 15  
**Microphone** ..... 200  
**Miracast®** ..... 134  
 Connecting a Miracast® device .. 135

N

**Navigation** ..... 64  
 Map screen ..... 64  
 Navigation menu screen ..... 67  
**“Navigation” button (“Setup” screen)** ..... 18, 102  
**Navigation database updates** ..... 111  
 Updating navigation database .... 111

O

**“Online” button (“Setup” screen)** 18, 231  
**Online search** ..... 233

**P**

**Panoramic view monitor (vehicles with Toyota Teammate Advanced Park) ..... 162**

- Camera switch ..... 162
- Customizing the panoramic view monitor..... 181
- How to switch the display..... 162
- If you notice any symptoms ..... 194
- Magnifying function ..... 180
- Panoramic view monitor precautions ..... 182
- When folding the outside rear view mirrors ..... 178
- When the shift position is in the “D” or “N” ..... 167
- When the shift position is in the “P” . 165
- When the shift position is in the “R” . 172

**Parking ..... 236**

- Displaying the Parking list screen ..... 236

**Phone ..... 198**

- About the contacts in the contact list ..... 202
- Phone screen operation..... 198
- Registering/Connecting a Bluetooth® phone ..... 200
- Some basics ..... 199
- Speech command system..... 201
- Troubleshooting ..... 223
- When selling or disposing of the vehicle ..... 202

- “Phone” button (“Menu” screen)..15**
- “Phone” button (“Setup” screen) .18**
- “PHONE” button .....198**
- Phone settings .....214**
  - Contact/Call history settings.....216
  - Message settings .....221
  - Notifications settings .....215
  - Sounds settings.....214
  - Toyota assistance settings .....222
- Placing a call using the Bluetooth® hands-free system.....203**
  - By call history .....203
  - By contacts list .....204
  - By favourites list .....204
  - By home screen .....206
  - By keypad .....205
  - SOS.....205
- “POWER VOLUME” knob..... 115**

## R

- Radio** ..... 120
  - RDS (Radio data system) ..... 123
- Rear view monitor system** ..... 154
  - Camera ..... 156
  - Differences between the screen and the actual road ..... 157
  - Driving precautions ..... 154
  - Precautions ..... 156
  - Screen description ..... 155
  - Things you should know ..... 160
  - When approaching three-dimensional objects ..... 158
- Receiving a call using the Bluetooth® hands-free system**.. 207
- Registering an entry**..... 98
  - Creating a new entry ..... 98
  - Displaying favourites list ..... 98
  - Downloading POIs and routes via the internet..... 99
  - Registering a quick access destinations ..... 98
  - Transferring POIs and routes via a USB memory ..... 99
- Registering home** .....21
  - Setting home as the destination ...22
- Registering/Connecting a Bluetooth® device** .....34
  - Profiles .....37
  - Registering a Bluetooth® audio player for the first time .....36
  - Registering a Bluetooth® phone for the first time .....34
- Route guidance**.....90
  - Pausing route guidance .....92
  - Route guidance screen .....90
  - Voice guidance.....91
- Route preferences settings** ..... 107
  - Displaying Manage stored destinations screen..... 108
  - Displaying route preferences screen ..... 107

## S

- Screen adjustment**.....31
- Search operation** .....78
  - Displaying the navigation menu screen .....78
  - Searching from favourites list.....80
  - Searching from last destinations ..82
  - Searching from the search box ....78
  - Viewing detail screen .....79

**Settings required for using the service** ..... **231**  
 Connecting to internet..... 231  
 Obtaining Toyota portal site account ..... 231

**“Setup” button (“Menu” screen)**. **15, 18**

**“Setup” screen** ..... **18**

**Speech command system** ..... **148**  
 Speech command system operation ..... 149  
 Using the speech command system ..... 148

**Starting route guidance** ..... **87**

**Status icon** ..... **16**  
 Status icon explanation..... 16

**Steering switch** ..... **137, 148**  
 Audio switch..... 137  
 Talk switch..... 148  
 TEL switch ..... 200

**Street View** ..... **235**  
 Displaying the Street View ..... 235

**System time settings** ..... **58**

**T**

**Talking on the Bluetooth® hands-free system** ..... **207**  
 Call screen operation ..... 207  
 Incoming call waiting ..... 209  
 Sending tones ..... 208  
 Switching calls while a call is in progress ..... 208  
 Transmit volume setting ..... 208

**Touch screen**..... **25**  
 Touch screen gestures ..... 25  
 Touch screen operation..... 26

**Toyota online**..... **228**  
 Before using Toyota online..... 230  
 Names and operations of each part ..... 228

**Toyota online settings**..... **239**  
 Toyota online settings screen..... 239

**Traffic message settings**..... **105**  
 Displaying traffic settings screen 105

**Traffic messages**..... **75**  
 Traffic message icon on the map .76  
 Traffic message list ..... 76  
 Traffic messages screen ..... 75

**U**

**USB memory** ..... **125**  
**USB port**..... **116**

V

“Vehicle” button (“Setup” screen) 18, 61

**Vehicle settings** ..... 61

- Displaying the vehicle settings screen ..... 61
- Setting the valet mode ..... 61
- Valet mode setting ..... 61
- Vehicle settings screen ..... 61

“Voice” button (“Setup” screen) 18, 60

**Voice settings** ..... 60

- Displaying the voice settings screen ..... 60
- Voice settings screen ..... 60

W

**Weather** ..... 235

- Changing location ..... 235
- Displaying the weather screen... 235

**Wi-Fi®** ..... 45

**Wi-Fi® button** (“Setup” screen) 18, 45

---



---

**For more information about the following items, see the “Owner’s Manual”.**

- Fuel consumption
- Vehicle customisation settings

**Toyota Motor Europe NV/SA,  
Avenue du Bourget 60 - 1140  
Brussels, Belgium  
[www.toyota-europe.com](http://www.toyota-europe.com)**



## Map database information and updates

### End User Terms

The data ("Data") is provided for your personal, internal use only and not for resale. It is protected by copyright, and is subject to the following terms and conditions which are agreed to by you, on the one hand, and Toyota and its licensors (including their licensors and suppliers) on the other hand.

© 2020 HERE. All rights reserved.

Personal Use Only. You agree to use this Data together with the Toyota multimedia system for the solely personal, non-commercial purposes for which you were licensed. Accordingly, but subject to the restrictions set forth in the following paragraphs, you agree not to otherwise reproduce, copy, modify, decompile, disassemble, create any derivative works of, or reverse engineer any portion of this Data, and may not transfer or distribute it in any form, for any purpose, except to the extent permitted by mandatory laws.

Restrictions. Except where you have been specifically licensed to do so by Toyota, and without limiting the preceding paragraph, you may not (a) use this Data with any products, systems, or applications installed or otherwise connected to or in communication with vehicles, capable of vehicle navigation, positioning, dispatch, real time route guidance, fleet management or similar applications; or (b) with or in communication with any positioning devices or any mobile or wireless-connected electronic or computer devices, including without limitation cellular phones, palmtop and handheld computers, pagers, and personal digital assistants or PDAs.

Warning. The Data may contain inaccurate or incomplete information due to the passage of time, changing circumstances, sources used and the nature of collecting comprehensive geographic data, any of which may lead to incorrect results.

No Warranty. This Data is provided to you "as is," and you agree to use it at your own risk. Toyota and its licensors (and their licensors and suppliers) make no guarantees, representations or warranties of any kind, express or implied, arising by law or otherwise, including but not limited to, content, quality, accuracy, completeness, effectiveness, reliability, fitness for a particular purpose, usefulness, use or results to be obtained from this Data, or that the Data or server will be uninterrupted or error-free.

Disclaimer of Warranty: Toyota AND ITS LICENSORS (INCLUDING THEIR LICENSORS AND SUPPLIERS) DISCLAIM ANY WARRANTIES, EXPRESS OR IMPLIED, OF QUALITY, PERFORMANCE, MERCHANTABILITY, FITNESS FOR A PARTICULAR PURPOSE OR NON-INFRINGEMENT. Some States, Territories and Countries do not allow certain warranty exclusions, so to that extent the above exclusion may not apply to you.

Disclaimer of Liability: TOYOTA AND ITS LICENSORS (INCLUDING THEIR LICENSORS AND SUPPLIERS) SHALL NOT BE LIABLE TO YOU: IN RESPECT OF ANY CLAIM, DEMAND OR ACTION, IRRESPECTIVE OF THE NATURE OF THE CAUSE OF THE CLAIM, DEMAND OR ACTION ALLEGING ANY LOSS, INJURY OR DAMAGES, DIRECT OR INDIRECT, WHICH MAY RESULT FROM

THE USE OR POSSESSION OF THE INFORMATION; OR FOR ANY LOSS OF PROFIT, REVENUE, CONTRACTS OR SAVINGS, OR ANY OTHER DIRECT, INDIRECT, INCIDENTAL, SPECIAL OR CONSEQUENTIAL DAMAGES ARISING OUT OF YOUR USE OF OR INABILITY TO USE THIS INFORMATION, ANY DEFECT IN THE INFORMATION, OR THE BREACH OF THESE TERMS OR CONDITIONS, WHETHER IN AN ACTION IN CONTRACT OR TORT OR BASED ON A WARRANTY, EVEN IF TOYOTA OR ITS LICENSORS HAVE BEEN ADVISED OF THE POSSIBILITY OF SUCH DAMAGES. Some States, Territories and Countries do not allow certain liability exclusions or damages limitations, so to that extent the above may not apply to you.

Entire Agreement. These terms and conditions constitute the entire agreement between Toyota (and its licensors, including their licensors and suppliers) and you pertaining to the subject matter hereof, and supersede in their entirety any and all written or oral agreements previously existing between us with respect to such subject matter.

Governing Law. The above terms and conditions shall be governed by the laws of The Netherlands, without giving effect to (i) its conflict of laws provisions, or (ii) the United Nations Convention for Contracts for the International Sale of Goods, which is explicitly excluded. You agree to submit to the jurisdiction of The Netherlands for any and all disputes, claims and actions arising from or in connection with the Data provided to you hereunder.

Government End Users. If the Data is being acquired by or on behalf of the United States government or any other entity seeking or applying rights similar to those customarily claimed by the United States government, this Data is a "commercial item" as that term is defined at 48 C.F.R. ("FAR") 2.101, is licensed in accordance with these End-User Terms, and each copy of Data delivered or otherwise furnished shall be marked and embedded as appropriate with the following "Notice of Use," and shall be treated in accordance with such Notice:

|   |
|---|
| <p style="text-align: center;"><b>NOTICE OF USE</b></p> <p>CONTRACTOR (MANUFACTURER/ SUPPLIER) NAME: HERE<br/>CONTRACTOR (MANUFACTURER/SUPPLIER) ADDRESS:<br/>425 West Randolph Street, Chicago, Illinois 60606</p> <p>This Data is a commercial item as defined in FAR 2.101 and is subject to these End-User Terms under which this Data was provided.</p> <p style="text-align: center;">© 1987 - 2020 HERE – All rights reserved.</p> |
|---|

If the Contracting Officer, federal government agency, or any federal official refuses to use the legend provided herein, the Contracting Officer, federal government agency, or any federal official must notify HERE prior to seeking additional or alternative rights in the Data.

## Certification

Information of the radio device: Type FT0106B

1. Name and postal address of the manufacturer  
 Name: DENSO TEN Limited  
 Address: 2-28, Goshō-dōri 1-chōme, Hyōgo-ku, Kobe, 652-8510 Japan

2. Simplified EU declaration of conformity

С настоящото DENSO TEN Limited декларира, че този тип радиосъоръжение FT0106B е в съответствие с Директива 2014/53/ЕС.  
 Цялостният текст на ЕС декларацията за съответствие може да се намери на следния интернет адрес:  
[https://www.denso-ten.com/support/regulation/eu\\_doc/](https://www.denso-ten.com/support/regulation/eu_doc/)

| Функция   | Работна честотна лента | Максимална радиочестотна мощност |
|-----------|------------------------|----------------------------------|
| Bluetooth | 2402 - 2480 MHz        | 4 dBm e.i.r.p.                   |
| WLAN      | 2412 - 2472 MHz        | 16 dBm e.i.r.p.                  |

Ovim putem, DENSO TEN Limited izjavljuje da je vrsta radio opreme FT0106B u saglasnosti s Direktivom 2014/53/EU.  
 Cijeli tekst EC deklaracije o usaglašenosti je dostupan na sljedećoj internetskoj adresi:  
[https://www.denso-ten.com/support/regulation/eu\\_doc/](https://www.denso-ten.com/support/regulation/eu_doc/)

| Funkcija  | Radni frekvencijski pojas | Maksimalna radiofrekvencijska snaga |
|-----------|---------------------------|-------------------------------------|
| Bluetooth | 2402 - 2480 MHz           | 4 dBm e.i.r.p.                      |
| WLAN      | 2412 - 2472 MHz           | 16 dBm e.i.r.p.                     |

Tímto DENSO TEN Limited prohlašuje, že typ rádiového zariadení FT0106B je v súlade so smernicou 2014/53/EU.  
 Úplné znění EU prohlášení o shodě je k dispozici na této internetové adrese:  
[https://www.denso-ten.com/support/regulation/eu\\_doc/](https://www.denso-ten.com/support/regulation/eu_doc/)

| Funkce    | Provozní frekvenční pásmo | Maximální radiofrekvenční výkon |
|-----------|---------------------------|---------------------------------|
| Bluetooth | 2402 - 2480 MHz           | 4 dBm e.i.r.p.                  |
| WLAN      | 2412 - 2472 MHz           | 16 dBm e.i.r.p.                 |

Hermed erklærer DENSO TEN Limited, at radioudstyrstypen FT0106B er i overensstemmelse med direktiv 2014/53/EU.  
 EU-overensstemmelseserklæringens fulde tekst kan findes på følgende internetadresse:  
[https://www.denso-ten.com/support/regulation/eu\\_doc/](https://www.denso-ten.com/support/regulation/eu_doc/)

| Funktion  | Driftsfrekvensbandet | Maksimal radio-frekvens effekt |
|-----------|----------------------|--------------------------------|
| Bluetooth | 2402 - 2480 MHz      | 4 dBm e.i.r.p.                 |
| WLAN      | 2412 - 2472 MHz      | 16 dBm e.i.r.p.                |

Hiermit erkläre DENSO TEN Limited, dass der Funkanlagentyp FT0106B der Richtlinie 2014/53/EU entspricht.  
 Der vollständige Text der EU-Konformitätserklärung ist unter der folgenden Internetadresse verfügbar:  
[https://www.denso-ten.com/support/regulation/eu\\_doc/](https://www.denso-ten.com/support/regulation/eu_doc/)

| Funktion  | Betriebsfrequenzband | Maximale Hochfrequenzleistung |
|-----------|----------------------|-------------------------------|
| Bluetooth | 2402 - 2480 MHz      | 4 dBm e.i.r.p.                |
| WLAN      | 2412 - 2472 MHz      | 16 dBm e.i.r.p.               |

Με την παρούσα ο/η DENSO TEN Limited, δηλώνει ότι ο ραδιοεξοπλισμός FT0106B πληροί την οδηγία 2014/53/ΕΕ.  
 Το πλήρες κείμενο της δήλωσης συμμόρφωσης ΕΕ διατίθεται στην ακόλουθη ιστοσελίδα στο διαδίκτυο:  
[https://www.denso-ten.com/support/regulation/eu\\_doc/](https://www.denso-ten.com/support/regulation/eu_doc/)

| Λειτουργία | Ζώνη συχνότητων λειτουργίας | Μέγιστη ισχύς ραδιοσυχνότητας |
|------------|-----------------------------|-------------------------------|
| Bluetooth  | 2402 - 2480 MHz             | 4 dBm e.i.r.p.                |
| WLAN       | 2412 - 2472 MHz             | 16 dBm e.i.r.p.               |

Hereby, DENSO TEN Limited declares that the radio equipment type FT0106B is in compliance with Directive 2014/53/EU.  
 The full text of the EU declaration of conformity is available at the following internet address:  
[https://www.denso-ten.com/support/regulation/eu\\_doc/](https://www.denso-ten.com/support/regulation/eu_doc/)

| Function  | Operating frequency band | Maximum radio-frequency power |
|-----------|--------------------------|-------------------------------|
| Bluetooth | 2402 - 2480 MHz          | 4 dBm e.i.r.p.                |
| WLAN      | 2412 - 2472 MHz          | 16 dBm e.i.r.p.               |

|  |                                      |   |
|--|--------------------------------------|---|
| <p>Por la presente, DENSO TEN Limited declara que el tipo de equipo radioeléctrico FT0106B es conforme con la Directiva 2014/53/UE. El texto completo de la declaración UE de conformidad está disponible en la dirección Internet siguiente:<br/> <a href="https://www.denso-ten.com/support/regulation/eu_doc/">https://www.denso-ten.com/support/regulation/eu_doc/</a></p> |                                      |   |
| Funci3n  | Banda de frecuencia operativa        | Potencia m3xima de la radiofrecuencia   |
| Bluetooth  | 2402 - 2480 MHz                      | 4 dBm e.i.r.p.                          |
| WLAN   | 2412 – 2472 MHz                      | 16 dBm e.i.r.p.                         |
| <p>K3esolevaga deklareerib DENSO TEN Limited, et k3esolev raadioseadme t3up FT0106B vastab direktiivi 2014/53/EL n3uetele. ELi vastavusdeklaratsiooni t3ielik tekst on k3ttesaadav j3rgmisel internetiaadressil:<br/> <a href="https://www.denso-ten.com/support/regulation/eu_doc/">https://www.denso-ten.com/support/regulation/eu_doc/</a></p>                              |                                      |   |
| Funksioon  | To3sageduse lainemaal                | Maksimaalne raadiosageduslik v3imsus    |
| Bluetooth  | 2402 - 2480 MHz                      | 4 dBm e.i.r.p.                          |
| WLAN   | 2412 – 2472 MHz                      | 16 dBm e.i.r.p.                         |
| <p>DENSO TEN Limited vakuuttaa, ett3 radiolaitetyypin FT0106B on direktiivin 2014/53/EU mukainen. EU-vaatimustenmukaisuusvakuutuksen t3ysimittainen teksti on saatavilla seuraavassa internetosoitteessa:<br/> <a href="https://www.denso-ten.com/support/regulation/eu_doc/">https://www.denso-ten.com/support/regulation/eu_doc/</a></p>                                     |                                      |   |
| Toiminto   | Toimintataajuuksikaista              | Maksimi radiotaajuusteho                |
| Bluetooth  | 2402 - 2480 MHz                      | 4 dBm e.i.r.p.                          |
| WLAN   | 2412 – 2472 MHz                      | 16 dBm e.i.r.p.                         |
| <p>Le soussign3, DENSO TEN Limited, d3clare que l'3quipement radio3lectrique du type FT0106B est conforme 3 la directive 2014/53/UE. Le texte complet de la d3claration UE de conformit3 est disponible 3 l'adresse internet suivante:<br/> <a href="https://www.denso-ten.com/support/regulation/eu_doc/">https://www.denso-ten.com/support/regulation/eu_doc/</a></p>        |                                      |   |
| Fonction   | Bande de fr3quence de fonctionnement | Puissance maximale de la radiofr3quence |
| Bluetooth  | 2402 - 2480 MHz                      | 4 dBm e.i.r.p.                          |
| WLAN   | 2412 – 2472 MHz                      | 16 dBm e.i.r.p.                         |
| <p>Leis seo, dearbhalonn DENSO TEN Limited go gcomhlionann an cineal trealaimh raidi3 FT0106B Treoir 2014/53/UE. T3 an t3acs ioml3n den dearbh3 comhr3reachta AE ar f3il ag an seoladh idir3il seo a leanas:<br/> <a href="https://www.denso-ten.com/support/regulation/eu_doc/">https://www.denso-ten.com/support/regulation/eu_doc/</a></p>                                  |                                      |   |
| Feidhm   | Banda miniciochta oibr3ch3in         | Uaschumhacht radaimhniciochta           |
| Bluetooth  | 2402 - 2480 MHz                      | 4 dBm e.i.r.p.                          |
| WLAN   | 2412 – 2472 MHz                      | 16 dBm e.i.r.p.                         |
| <p>DENSO TEN Limited ovime izjavljuje da je radijska oprema tipa FT0106B u skladu s Direktivom 2014/53/UE. Cjeloviti tekst EU izjave o sukladnosti dostupan je na sljedećoj internetskoj adresi:<br/> <a href="https://www.denso-ten.com/support/regulation/eu_doc/">https://www.denso-ten.com/support/regulation/eu_doc/</a></p>  |                                      |   |
| Funkcija   | Radni frekvencijski pojas            | Maksimalna radiofrekvencijska snaga     |
| Bluetooth  | 2402 - 2480 MHz                      | 4 dBm e.i.r.p.                          |
| WLAN   | 2412 – 2472 MHz                      | 16 dBm e.i.r.p.                         |
| <p>DENSO TEN Limited igazolja, hogy a FT0106B t3pus3 r3di3berendez3s megfelel a 2014/53/UE ir3nyelvnek. Az EU-megfelel3s3gi nyilatkozat teljes sz3vege el3rhet3 a k3vetkez3 internetes c3men:<br/> <a href="https://www.denso-ten.com/support/regulation/eu_doc/">https://www.denso-ten.com/support/regulation/eu_doc/</a></p>   |                                      |   |
| Funkció  | 3zemi frekvencia-tartom3ny           | Maxim3lis r3di3frekvenci3s teljes3tm3ny |
| Bluetooth  | 2402 - 2480 MHz                      | 4 dBm e.i.r.p.                          |
| WLAN   | 2412 – 2472 MHz                      | 16 dBm e.i.r.p.                         |
| <p>H3r me3, l3ysir DENSO TEN Limited því yfir a3 ger3 utvarpsb3na3darins FT0106B samr3mist tilskipun 2014/53/UE. Allur texti ESB-samr3misyrfirlysingarinnar er a3gengilegur 3 eftirfarandi veffangi:<br/> <a href="https://www.denso-ten.com/support/regulation/eu_doc/">https://www.denso-ten.com/support/regulation/eu_doc/</a></p>  |                                      |   |
| A3ger3   | Notkunart33ni hj3msveit              | H3marks3 utvarp-t33ni vald              |
| Bluetooth  | 2402 - 2480 MHz                      | 4 dBm e.i.r.p.                          |
| WLAN   | 2412 – 2472 MHz                      | 16 dBm e.i.r.p.                         |

Il fabbricante, DENSO TEN Limited, dichiara che il tipo di apparecchiatura radio FT0106B è conforme alla direttiva 2014/53/UE.  
Il testo completo della dichiarazione di conformità UE è disponibile al seguente indirizzo Internet:

[https://www.denso-ten.com/support/regulation/eu\\_doc/](https://www.denso-ten.com/support/regulation/eu_doc/)

| Funzione  | Frequenza operativa | Massima potenza a radiofrequenza |
|-----------|---------------------|----------------------------------|
| Bluetooth | 2402 - 2480 MHz     | 4 dBm e.i.r.p.                   |
| WLAN      | 2412 - 2472 MHz     | 16 dBm e.i.r.p.                  |

Aš, DENSO TEN Limited, patvirtinu, kad radijo įrenginių tipas FT0106B atitinka Direktyvą 2014/53/ES.

Visas ES atitikties deklaracijos tekstas prieinamas šiuo interneto adresu:

[https://www.denso-ten.com/support/regulation/eu\\_doc/](https://www.denso-ten.com/support/regulation/eu_doc/)

| Funkcija  | Veikimo dažnių juosta | Maksimalus radijo dažnių galingumas |
|-----------|-----------------------|-------------------------------------|
| Bluetooth | 2402 - 2480 MHz       | 4 dBm e.i.r.p.                      |
| WLAN      | 2412 - 2472 MHz       | 16 dBm e.i.r.p.                     |

Ar šo DENSO TEN Limited deklarė, ka radioiekārta FT0106B atbilst Direktīvai 2014/53/ES.

Pilns ES atbilstības deklarācijas teksts ir pieejams šādā interneta vietnē:

[https://www.denso-ten.com/support/regulation/eu\\_doc/](https://www.denso-ten.com/support/regulation/eu_doc/)

| Funkcija  | Darba frekvences josla | Maksimālā radiofrekvences jauda |
|-----------|------------------------|---------------------------------|
| Bluetooth | 2402 - 2480 MHz        | 4 dBm e.i.r.p.                  |
| WLAN      | 2412 - 2472 MHz        | 16 dBm e.i.r.p.                 |

Со ова, DENSO TEN Limited изјавува дека радио опремата од типот FT0106B е во согласност со Директивата 2014/53/EU.

Целот текст на ЕУ изјавата за сообразност е достапен на следната интернет адреса:

[https://www.denso-ten.com/support/regulation/eu\\_doc/](https://www.denso-ten.com/support/regulation/eu_doc/)

| Функција  | Работен фреквенциски опсег | Максимална радио-фреквенциска моќ |
|-----------|----------------------------|-----------------------------------|
| Bluetooth | 2402 - 2480 MHz            | 4 dBm e.i.r.p.                    |
| WLAN      | 2412 - 2472 MHz            | 16 dBm e.i.r.p.                   |

Ovim, DENSO TEN Limited izjavljuje da je tip radio opreme FT0106B u skladu sa Direktivom 2014/53/EU.

Cjelokupan tekst EU deklaracije o usklađenosti dostupan je na sljedećoj internet adresi:

[https://www.denso-ten.com/support/regulation/eu\\_doc/](https://www.denso-ten.com/support/regulation/eu_doc/)

| Funkcija  | Operativni frekvencijski opseg | Maksimalna jačina radio frekvencije |
|-----------|--------------------------------|-------------------------------------|
| Bluetooth | 2402 - 2480 MHz                | 4 dBm e.i.r.p.                      |
| WLAN      | 2412 - 2472 MHz                | 16 dBm e.i.r.p.                     |

B'dan, DENSO TEN Limited, niddikjara li dan it-tip ta' taghmir tar-radju FT0106B huwa konformi mad-Direttiva 2014/53/UE.

It-test kollu tad-dikjarazzjoni ta' konformità tal-UE huwa disponibbli f'dan l-indirizz tal-Internet li ġej:

[https://www.denso-ten.com/support/regulation/eu\\_doc/](https://www.denso-ten.com/support/regulation/eu_doc/)

| Funzjoni  | Band tal-frekwenza operattiva | I-energija massima bi frekwenza tar-radju |
|-----------|-------------------------------|---|
| Bluetooth | 2402 - 2480 MHz               | 4 dBm e.i.r.p.                            |
| WLAN      | 2412 - 2472 MHz               | 16 dBm e.i.r.p.                           |

Hierbij verklaar ik, DENSO TEN Limited, dat het type radioapparatuur FT0106B conform is met Richtlijn 2014/53/EU.

De volledige tekst van de EU-conformiteitsverklaring kan worden geraadpleegd op het volgende internetadres:

[https://www.denso-ten.com/support/regulation/eu\\_doc/](https://www.denso-ten.com/support/regulation/eu_doc/)

| Funcție   | Activele frecvențeband | Maximale radiofrecvenție |
|-----------|------------------------|--------------------------|
| Bluetooth | 2402 - 2480 MHz        | 4 dBm e.i.r.p.           |
| WLAN      | 2412 - 2472 MHz        | 16 dBm e.i.r.p.          |

DENSO TEN Limited erklærer herved at radioutstyrstypen FT0106B er i samsvar med direktiv 2014/53/EU.

Den fullestendige teksten i EU-erklæringen er tilgjengelig på følgende internetadresse:

[https://www.denso-ten.com/support/regulation/eu\\_doc/](https://www.denso-ten.com/support/regulation/eu_doc/)

| Funksjon  | Driftsfrekvensbånd | Maksimal radiofrekvent strøm |
|-----------|--------------------|------------------------------|
| Bluetooth | 2402 - 2480 MHz    | 4 dBm e.i.r.p.               |
| WLAN      | 2412 - 2472 MHz    | 16 dBm e.i.r.p.              |

DENSO TEN Limited niniejszym oświadcza, że typ urządzenia radiowego FT0106B jest zgodny z dyrektywą 2014/53/UE.  
Pełny tekst deklaracji zgodności UE jest dostępny pod następującym adresem internetowym:

[https://www.denso-ten.com/support/regulation/eu\\_doc/](https://www.denso-ten.com/support/regulation/eu_doc/)

| Funkcja   | Pasmo częstotliwości pracy | Maksymalna moc częstotliwości radiowej |
|-----------|----------------------------|--|
| Bluetooth | 2402 - 2480 MHz            | 4 dBm e.i.r.p.                         |
| WLAN      | 2412 – 2472 MHz            | 16 dBm e.i.r.p.                        |

O(a) abaixo assinado(a) DENSO TEN Limited declara que o presente tipo de equipamento de rádio FT0106B está em conformidade com a Diretiva 2014/53/UE.

O texto integral da declaração de conformidade está disponível no seguinte endereço de Internet:

[https://www.denso-ten.com/support/regulation/eu\\_doc/](https://www.denso-ten.com/support/regulation/eu_doc/)

| Função    | Faixa de frequência operacional | Potência máxima de radiofrequência |
|-----------|---------------------------------|------------------------------------|
| Bluetooth | 2402 - 2480 MHz                 | 4 dBm e.i.r.p.                     |
| WLAN      | 2412 – 2472 MHz                 | 16 dBm e.i.r.p.                    |

Prin prezenta, DENSO TEN Limited declară că tipul de echipamente radio FT0106B este în conformitate cu Directiva 2014/53/UE.

Textul integral al declarației UE de conformitate este disponibil la următoarea adresă internet:

[https://www.denso-ten.com/support/regulation/eu\\_doc/](https://www.denso-ten.com/support/regulation/eu_doc/)

| Funcție   | Bandă de frecvență activă | Puterea maximă a radio-frecvenței |
|-----------|---------------------------|-----------------------------------|
| Bluetooth | 2402 - 2480 MHz           | 4 dBm e.i.r.p.                    |
| WLAN      | 2412 – 2472 MHz           | 16 dBm e.i.r.p.                   |

DENSO TEN Limited týmto vyhlasuje, že rádiové zariadenie typu FT0106B je v súlade so smernicou 2014/53/EÚ.

Úplné EÚ vyhlásenie o zhode je k dispozícii na tejto internetovej adrese:

[https://www.denso-ten.com/support/regulation/eu\\_doc/](https://www.denso-ten.com/support/regulation/eu_doc/)

| Funkcia   | Prevádzkové frekvenčné pásmo | Maximálny rádiový frekvenčný výkon |
|-----------|------------------------------|------------------------------------|
| Bluetooth | 2402 - 2480 MHz              | 4 dBm e.i.r.p.                     |
| WLAN      | 2412 – 2472 MHz              | 16 dBm e.i.r.p.                    |

DENSO TEN Limited potrjuje, da je tip radijske opreme FT0106B skladen z Direktivo 2014/53/EU.

Celotno besedilo izjave EU o skladnosti je na voljo na naslednjem spletnem naslovu:

[https://www.denso-ten.com/support/regulation/eu\\_doc/](https://www.denso-ten.com/support/regulation/eu_doc/)

| Funkcija  | Delovni frekvenčni pas | Maksimalna radiofrekvenčna moč |
|-----------|------------------------|--------------------------------|
| Bluetooth | 2402 - 2480 MHz        | 4 dBm e.i.r.p.                 |
| WLAN      | 2412 – 2472 MHz        | 16 dBm e.i.r.p.                |

Népérmjett kérésaj, DENSO TEN Limited deklaron se lloji i aparatit të radios FT0106B është në përputhje me Direktivën 2014/53/UE.

Teksti i plotë i deklaratës së BE-së mbi përputhshmërinë është i disponueshëm në adresën e mëposhtme të internetit:

[https://www.denso-ten.com/support/regulation/eu\\_doc/](https://www.denso-ten.com/support/regulation/eu_doc/)

| Funksion  | Banda e frekuencës së punës | Fuqia maksimale e frekuencave radio |
|-----------|-----------------------------|-------------------------------------|
| Bluetooth | 2402 - 2480 MHz             | 4 dBm e.i.r.p.                      |
| WLAN      | 2412 – 2472 MHz             | 16 dBm e.i.r.p.                     |

Ovim, DENSO TEN Limited izjavljuje da je ovaj tip radijske opreme FT0106B u skladu sa odredbama Direktive 2014/53/EU.

Kompletan tekst EU deklaracije o konformitetu je dostupan na sledećoj internet adresi:

[https://www.denso-ten.com/support/regulation/eu\\_doc/](https://www.denso-ten.com/support/regulation/eu_doc/)

| Funkcija  | Radni frekvencijski pojas | Maksimalna radiofrekvencijska snaga |
|-----------|---------------------------|-------------------------------------|
| Bluetooth | 2402 - 2480 MHz           | 4 dBm e.i.r.p.                      |
| WLAN      | 2412 – 2472 MHz           | 16 dBm e.i.r.p.                     |

Härmed försäkrar DENSO TEN Limited att denna typ av radioutrustning FT0106B överensstämmer med direktiv 2014/53/EU.

Den fullständiga texten till EU-försäkran om överensstämmelse finns på följande webbadress:

[https://www.denso-ten.com/support/regulation/eu\\_doc/](https://www.denso-ten.com/support/regulation/eu_doc/)

| Funktion  | Operationsfrekvensbandet | Maximal radiofrekvensseffekt |
|-----------|--------------------------|------------------------------|
| Bluetooth | 2402 - 2480 MHz          | 4 dBm e.i.r.p.               |
| WLAN      | 2412 – 2472 MHz          | 16 dBm e.i.r.p.              |

DENSO TEN Limited, FT0106B türü telsiz ekipmanının 2014/53/EU Direktifine uygun olduğunu beyan etmektedir.  
AB uygunluk beyanının tam metnine aşağıdaki internet adresinden ulaşılabilir:  
[https://www.denso-ten.com/support/regulation/eu\\_doc/](https://www.denso-ten.com/support/regulation/eu_doc/)

| İşlev     | Çalışma frekans bandı | Maksimum radyo-frekans gücü |
|-----------|-----------------------|-----------------------------|
| Bluetooth | 2402 - 2480 MHz       | 4 dBm e.i.r.p.              |
| WLAN      | 2412 – 2472 MHz       | 16 dBm e.i.r.p.             |

Information of the radio device: Type FT0106C

- Name and postal address of the manufacturer  
Name: DENSO TEN Limited  
Address: 2-28, Goshō-dori 1-chome, Hyogo-ku, Kobe, 652-8510 Japan
- Simplified EU declaration of conformity

С настоящото DENSO TEN Limited декларира, че този тип радиосъоръжение FT0106C е в съответствие с Директива 2014/53/ЕС.  
Цялостният текст на ЕС декларацията за съответствие може да се намери на следния интернет адрес:  
[https://www.denso-ten.com/support/regulation/eu\\_doc/](https://www.denso-ten.com/support/regulation/eu_doc/)

| Функция   | Работна честотна лента | Максимална радиочестотна мощност |
|-----------|------------------------|----------------------------------|
| Bluetooth | 2402 - 2480 MHz        | 4 dBm e.i.r.p.                   |
| WLAN      | 2412 – 2472 MHz        | 16 dBm e.i.r.p.                  |

Ovim putem, DENSO TEN Limited izjavljuje da je vrsta radio opreme FT0106C u saglasnosti s Direktivom 2014/53/EU.  
Cijeli tekst EC deklaracije o usaglašenosti je dostupan na sljedećoj internetskoj adresi:  
[https://www.denso-ten.com/support/regulation/eu\\_doc/](https://www.denso-ten.com/support/regulation/eu_doc/)

| Funkcija  | Radni frekventijski pojas | Maksimalna radiofrekventijska snaga |
|-----------|---------------------------|-------------------------------------|
| Bluetooth | 2402 - 2480 MHz           | 4 dBm e.i.r.p.                      |
| WLAN      | 2412 – 2472 MHz           | 16 dBm e.i.r.p.                     |

Tímto DENSO TEN Limited prohlašuje, že typ rádiového zařízení FT0106C je v souladu se směrnicí 2014/53/EU.  
Úplné znění EU prohlášení o shodě je k dispozici na této internetové adrese:  
[https://www.denso-ten.com/support/regulation/eu\\_doc/](https://www.denso-ten.com/support/regulation/eu_doc/)

| Funkce    | Provozní frekvenční pásmo | Maximální radiofrekvenční výkon |
|-----------|---------------------------|---------------------------------|
| Bluetooth | 2402 - 2480 MHz           | 4 dBm e.i.r.p.                  |
| WLAN      | 2412 – 2472 MHz           | 16 dBm e.i.r.p.                 |

|   |                                      |   |
|---|--------------------------------------|---|
| <p>Hiermed erklærer DENSO TEN Limited, at radioudstyrstypen FT0106C er i overensstemmelse med direktiv 2014/53/EU.<br/>         EU-overensstemmelseserklæringens fulde tekst kan findes på følgende internetadresse:<br/> <a href="https://www.denso-ten.com/support/regulation/eu_doc/">https://www.denso-ten.com/support/regulation/eu_doc/</a></p>                                       |                                      |   |
| Funktion  | Driftsfrekvensbandet                 | Maksimal radio-frekvens effekt          |
| Bluetooth   | 2402 - 2480 MHz                      | 4 dBm e.i.r.p.                          |
| WLAN  | 2412 – 2472 MHz                      | 16 dBm e.i.r.p.                         |
| <p>Hiermit erklart DENSO TEN Limited, dass der Funkanlagentyp FT0106C der Richtlinie 2014/53/EU entspricht.<br/>         Der vollständige Text der EU-Konformitätserklärung ist unter der folgenden Internetadresse verfügbar:<br/> <a href="https://www.denso-ten.com/support/regulation/eu_doc/">https://www.denso-ten.com/support/regulation/eu_doc/</a></p>                             |                                      |   |
| Funktion  | Betriebsfrequenzband                 | Maximale Hochfrequenzleistung           |
| Bluetooth   | 2402 - 2480 MHz                      | 4 dBm e.i.r.p.                          |
| WLAN  | 2412 – 2472 MHz                      | 16 dBm e.i.r.p.                         |
| <p>Με την παρούσα ο/η DENSO TEN Limited, δηλώνει ότι ο ραδιοεξοπλισμός FT0106C πληροί την οδηγία 2014/53/ΕΕ.<br/>         Το πλήρες κείμενο της δήλωσης συμμόρφωσης ΕΕ διατίθεται στην ακόλουθη ιστοσελίδα στο διαδίκτυο:<br/> <a href="https://www.denso-ten.com/support/regulation/eu_doc/">https://www.denso-ten.com/support/regulation/eu_doc/</a></p>                                  |                                      |   |
| Λειτουργία  | Ζώνη συχνότητων λειτουργίας          | Μέγιστη ισχύς ραδιοσυχνότητας           |
| Bluetooth   | 2402 - 2480 MHz                      | 4 dBm e.i.r.p.                          |
| WLAN  | 2412 – 2472 MHz                      | 16 dBm e.i.r.p.                         |
| <p>Hereby, DENSO TEN Limited declares that the radio equipment type FT0106C is in compliance with Directive 2014/53/EU.<br/>         The full text of the EU declaration of conformity is available at the following internet address:<br/> <a href="https://www.denso-ten.com/support/regulation/eu_doc/">https://www.denso-ten.com/support/regulation/eu_doc/</a></p>                     |                                      |   |
| Function  | Operating frequency band             | Maximum radio-frequency power           |
| Bluetooth   | 2402 - 2480 MHz                      | 4 dBm e.i.r.p.                          |
| WLAN  | 2412 – 2472 MHz                      | 16 dBm e.i.r.p.                         |
| <p>Por la presente, DENSO TEN Limited declara que el tipo de equipo radioeléctrico FT0106C es conforme con la Directiva 2014/53/UE.<br/>         El texto completo de la declaración UE de conformidad está disponible en la dirección Internet siguiente:<br/> <a href="https://www.denso-ten.com/support/regulation/eu_doc/">https://www.denso-ten.com/support/regulation/eu_doc/</a></p> |                                      |   |
| Función   | Banda de frecuencia operativa        | Potencia máxima de la radiofrecuencia   |
| Bluetooth   | 2402 - 2480 MHz                      | 4 dBm e.i.r.p.                          |
| WLAN  | 2412 – 2472 MHz                      | 16 dBm e.i.r.p.                         |
| <p>Käesolevaga deklareerib DENSO TEN Limited, et käesolev raadioseadme tüüp FT0106C vastab direktiivi 2014/53/EL nõuetele.<br/>         ELi vastavusdeklaratsiooni täielik tekst on kättesaadav järgmisel internetiaadressil:<br/> <a href="https://www.denso-ten.com/support/regulation/eu_doc/">https://www.denso-ten.com/support/regulation/eu_doc/</a></p>                              |                                      |   |
| Funktsioon  | Töösageduse laineval                 | Maksimaalne raadiosageduslik võimsus    |
| Bluetooth   | 2402 - 2480 MHz                      | 4 dBm e.i.r.p.                          |
| WLAN  | 2412 – 2472 MHz                      | 16 dBm e.i.r.p.                         |
| <p>DENSO TEN Limited vakuuttaa, että radiolaitetyyppi FT0106C on direktiivin 2014/53/EU mukainen.<br/>         EU-vaatimustenmukaisuusvakuutuksen täysimittainen teksti on saatavilla seuraavassa internetosoitteessa:<br/> <a href="https://www.denso-ten.com/support/regulation/eu_doc/">https://www.denso-ten.com/support/regulation/eu_doc/</a></p>                                     |                                      |   |
| Toiminto  | Toimintataajuuskaista                | Maksimi radiotaajuusteho                |
| Bluetooth   | 2402 - 2480 MHz                      | 4 dBm e.i.r.p.                          |
| WLAN  | 2412 – 2472 MHz                      | 16 dBm e.i.r.p.                         |
| <p>Le soussigné, DENSO TEN Limited, déclare que l'équipement radioélectrique du type FT0106C est conforme à la directive 2014/53/UE.<br/>         Le texte complet de la déclaration UE de conformité est disponible à l'adresse internet suivante:<br/> <a href="https://www.denso-ten.com/support/regulation/eu_doc/">https://www.denso-ten.com/support/regulation/eu_doc/</a></p>        |                                      |   |
| Fonction  | Bande de fréquence de fonctionnement | Puissance maximale de la radiofréquence |
| Bluetooth   | 2402 - 2480 MHz                      | 4 dBm e.i.r.p.                          |
| WLAN  | 2412 – 2472 MHz                      | 16 dBm e.i.r.p.                         |

|  |                               |   |
|--|-------------------------------|---|
| Leis seo, dearbhaíonn DENSO TEN Limited go gcomhlíonann an cineál trealaimh raidió FT0106C Treoir 2014/53/EU.                  |                               |   |
| Tá an téacs iomlán den dearbhú comhréireachta AE ar fáil ag an seoladh Idirlin seo a leanas:                                   |                               |   |
| <a href="https://www.denso-ten.com/support/regulation/eu_doc/">https://www.denso-ten.com/support/regulation/eu_doc/</a>        |                               |   |
| Feidhm   | Banda minicíochta oibriúcháin | Uaschumhacht radaimhnicíochta           |
| Bluetooth  | 2402 - 2480 MHz               | 4 dBm e.i.r.p.                          |
| WLAN   | 2412 – 2472 MHz               | 16 dBm e.i.r.p.                         |
| DENSO TEN Limited ovime izjavljuje da je radijska oprema tipa FT0106C u skladu s Direktivom 2014/53/EU.                        |                               |   |
| Cjeloviti tekst EU izjave o sukladnosti dostupan je na sljedećoj internetskoj adresi:  |                               |   |
| <a href="https://www.denso-ten.com/support/regulation/eu_doc/">https://www.denso-ten.com/support/regulation/eu_doc/</a>        |                               |   |
| Funkcija   | Radni frekvencijski pojas     | Maksimalna radiofrekvencijska snaga     |
| Bluetooth  | 2402 - 2480 MHz               | 4 dBm e.i.r.p.                          |
| WLAN   | 2412 – 2472 MHz               | 16 dBm e.i.r.p.                         |
| DENSO TEN Limited igazolja, hogy a FT0106C típusú rádióberendezés megfelel a 2014/53/EU irányelvnek.                           |                               |   |
| Az EU-megfelelőségi nyilatkozat teljes szövege elérhető a következő internetes címen:  |                               |   |
| <a href="https://www.denso-ten.com/support/regulation/eu_doc/">https://www.denso-ten.com/support/regulation/eu_doc/</a>        |                               |   |
| Funkció  | Üzemi frekvencia-tartomány    | Maximális rádiófrekvenciás teljesítmény |
| Bluetooth  | 2402 - 2480 MHz               | 4 dBm e.i.r.p.                          |
| WLAN   | 2412 – 2472 MHz               | 16 dBm e.i.r.p.                         |
| Hér með, lýsir DENSO TEN Limited því yfir að gerð útværpsbúnaðarins FT0106C samræmist tilskipun 2014/53/EU.                    |                               |   |
| Allur texti ESB-samræmisýfirlýsingarinnar er aðgengilegur á eftirfarandi veffangi:   |                               |   |
| <a href="https://www.denso-ten.com/support/regulation/eu_doc/">https://www.denso-ten.com/support/regulation/eu_doc/</a>        |                               |   |
| Aðgerð   | Notkunartíðni hjómsveit       | Hámarks útvarp-tíðni vald               |
| Bluetooth  | 2402 - 2480 MHz               | 4 dBm e.i.r.p.                          |
| WLAN   | 2412 – 2472 MHz               | 16 dBm e.i.r.p.                         |
| Il fabbricante, DENSO TEN Limited, dichiara che il tipo di apparecchiatura radio FT0106C è conforme alla direttiva 2014/53/UE. |                               |   |
| Il testo completo della dichiarazione di conformità UE è disponibile al seguente indirizzo Internet:                           |                               |   |
| <a href="https://www.denso-ten.com/support/regulation/eu_doc/">https://www.denso-ten.com/support/regulation/eu_doc/</a>        |                               |   |
| Funzione   | Frequenza operativa           | Massima potenza a radiofrequenza        |
| Bluetooth  | 2402 - 2480 MHz               | 4 dBm e.i.r.p.                          |
| WLAN   | 2412 – 2472 MHz               | 16 dBm e.i.r.p.                         |
| Aš, DENSO TEN Limited, patvirtinu, kad radijo įrenginių tipas FT0106C atitinka Direktyvą 2014/53/ES.                           |                               |   |
| Visas ES atitikties deklaracijos tekstas prieinamas šiuo interneto adresu:   |                               |   |
| <a href="https://www.denso-ten.com/support/regulation/eu_doc/">https://www.denso-ten.com/support/regulation/eu_doc/</a>        |                               |   |
| Funkcija   | Veikimo dažnių juosta         | Maksimalus radijo dažnių galingumas     |
| Bluetooth  | 2402 - 2480 MHz               | 4 dBm e.i.r.p.                          |
| WLAN   | 2412 – 2472 MHz               | 16 dBm e.i.r.p.                         |
| Ar šo DENSO TEN Limited deklarė, ka radioiekārta FT0106C atbilst Direktīvai 2014/53/ES.  |                               |   |
| Pilns ES atbilstības deklarācijas teksts ir pieejams šādā interneta vietnē:  |                               |   |
| <a href="https://www.denso-ten.com/support/regulation/eu_doc/">https://www.denso-ten.com/support/regulation/eu_doc/</a>        |                               |   |
| Funkcija   | Darba frekvences josla        | Maksimālā radiofrekvences jauda         |
| Bluetooth  | 2402 - 2480 MHz               | 4 dBm e.i.r.p.                          |
| WLAN   | 2412 – 2472 MHz               | 16 dBm e.i.r.p.                         |
| Со ова, DENSO TEN Limited изјавува дека радио опремата од типот FT0106C е во согласност со Директивата 2014/53/EU.             |                               |   |
| Целиот текст на ЕУ изјавата за сообразност е достапен на следната интернет адреса:   |                               |   |
| <a href="https://www.denso-ten.com/support/regulation/eu_doc/">https://www.denso-ten.com/support/regulation/eu_doc/</a>        |                               |   |
| Функција   | Работен фреквенциски опсег    | Максимална радио-фреквенциска моќ       |
| Bluetooth  | 2402 - 2480 MHz               | 4 dBm e.i.r.p.                          |
| WLAN   | 2412 – 2472 MHz               | 16 dBm e.i.r.p.                         |

Ovim, DENSO TEN Limited izjavljuje da je tip radio opreme FT0106C u skladu sa Direktivom 2014/53/EU.

Cjelokupan tekst EU deklaracije o usklađenosti dostupan je na sljedećoj internet adresi:

[https://www.denso-ten.com/support/regulation/eu\\_doc/](https://www.denso-ten.com/support/regulation/eu_doc/)

| Funkcija  | Operativni frekventijski opseg | Maksimalna jačina radio frekvencije |
|-----------|--------------------------------|-------------------------------------|
| Bluetooth | 2402 - 2480 MHz                | 4 dBm e.i.r.p.                      |
| WLAN      | 2412 – 2472 MHz                | 16 dBm e.i.r.p.                     |

B'dan, DENSO TEN Limited, niddikjara li dan it-tip ta' tagħmir tar-radju FT0106C huwa konformi mad-Direttiva 2014/53/UE.

It-test kollu tad-dikjarazzjoni ta' konformità tal-UE huwa disponibbli f'dan l-indirizz tal-Internet li ġej:

[https://www.denso-ten.com/support/regulation/eu\\_doc/](https://www.denso-ten.com/support/regulation/eu_doc/)

| Funzjoni  | Band tal-frekwenza operattiva | I-enerġija massima bi frekwenza tar-radju |
|-----------|-------------------------------|---|
| Bluetooth | 2402 - 2480 MHz               | 4 dBm e.i.r.p.                            |
| WLAN      | 2412 – 2472 MHz               | 16 dBm e.i.r.p.                           |

Hierbij verklaar ik, DENSO TEN Limited, dat het type radioapparatuur FT0106C conform is met Richtlijn 2014/53/UE.

De volledige tekst van de EU-conformiteitsverklaring kan worden geraadpleegd op het volgende internetadres:

[https://www.denso-ten.com/support/regulation/eu\\_doc/](https://www.denso-ten.com/support/regulation/eu_doc/)

| Funcție   | Actieve frequentieband | Maximale radiofrequentie |
|-----------|------------------------|--------------------------|
| Bluetooth | 2402 - 2480 MHz        | 4 dBm e.i.r.p.           |
| WLAN      | 2412 – 2472 MHz        | 16 dBm e.i.r.p.          |

DENSO TEN Limited erklærer herved at radioutstyrstypen FT0106C er i samsvar med direktiv 2014/53/UE.

Den fullestendige teksten i EU-erklæringen er tilgjengelig på følgende internetadresse:

[https://www.denso-ten.com/support/regulation/eu\\_doc/](https://www.denso-ten.com/support/regulation/eu_doc/)

| Funksjon  | Driftsfrekvensbånd | Maksimal radiofrekvent strøm |
|-----------|--------------------|------------------------------|
| Bluetooth | 2402 - 2480 MHz    | 4 dBm e.i.r.p.               |
| WLAN      | 2412 – 2472 MHz    | 16 dBm e.i.r.p.              |

DENSO TEN Limited niniejszym oświadczam, że typ urządzenia radiowego FT0106C jest zgodny z dyrektywą 2014/53/UE.

Pełny tekst deklaracji zgodności UE jest dostępny pod następującym adresem internetowym:

[https://www.denso-ten.com/support/regulation/eu\\_doc/](https://www.denso-ten.com/support/regulation/eu_doc/)

| Funkcja   | Pasma częstotliwości pracy | Maksymalna moc częstotliwości radiowej |
|-----------|----------------------------|--|
| Bluetooth | 2402 - 2480 MHz            | 4 dBm e.i.r.p.                         |
| WLAN      | 2412 – 2472 MHz            | 16 dBm e.i.r.p.                        |

O(a) abaixo assinado(a) DENSO TEN Limited declara que o presente tipo de equipamento de rádio FT0106C está em conformidade com a Diretiva 2014/53/UE.

O texto integral da declaração de conformidade está disponível no seguinte endereço de Internet:

[https://www.denso-ten.com/support/regulation/eu\\_doc/](https://www.denso-ten.com/support/regulation/eu_doc/)

| Função    | Faixa de frequência operacional | Potência máxima de radiofrequência |
|-----------|---------------------------------|------------------------------------|
| Bluetooth | 2402 - 2480 MHz                 | 4 dBm e.i.r.p.                     |
| WLAN      | 2412 – 2472 MHz                 | 16 dBm e.i.r.p.                    |

Prin prezenta, DENSO TEN Limited declară că tipul de echipamente radio FT0106C este în conformitate cu Directiva 2014/53/UE.

Textul integral al declarației UE de conformitate este disponibil la următoarea adresă internet:

[https://www.denso-ten.com/support/regulation/eu\\_doc/](https://www.denso-ten.com/support/regulation/eu_doc/)

| Funcție   | Bandă de frecvență activă | Puterea maximă a radio-frecvenței |
|-----------|---------------------------|-----------------------------------|
| Bluetooth | 2402 - 2480 MHz           | 4 dBm e.i.r.p.                    |
| WLAN      | 2412 – 2472 MHz           | 16 dBm e.i.r.p.                   |

DENSO TEN Limited týmto vyhlasuje, že rádiové zariadenie typu FT0106C je v súlade so smernicou 2014/53/UE.

Úplné EÚ vyhlásenie o zhode je k dispozícii na tejto internetovej adrese:

[https://www.denso-ten.com/support/regulation/eu\\_doc/](https://www.denso-ten.com/support/regulation/eu_doc/)

| Funkcia   | Prevádzkové frekvenčné pásmo | Maximálny rádiový výkon |
|-----------|------------------------------|-------------------------|
| Bluetooth | 2402 - 2480 MHz              | 4 dBm e.i.r.p.          |
| WLAN      | 2412 – 2472 MHz              | 16 dBm e.i.r.p.         |

|  |                             |                                       |
|--|-----------------------------|---------------------------------------|
| DENSO TEN Limited potruje, da je tip radijske opreme FT0106C skladen z Direktivo 2014/53/EU.<br>Celotno besedilo izjave EU o skladnosti je na voljo na naslednjem spletnem naslovu:<br><a href="https://www.denso-ten.com/support/regulation/eu_doc/">https://www.denso-ten.com/support/regulation/eu_doc/</a>   |                             |                                       |
| Funkcija   | Delovni frekvenčni pas      | Maksimalna radiofrekvenčna moč        |
| Bluetooth  | 2402 - 2480 MHz             | 4 dBm e.i.r.p.                        |
| WLAN   | 2412 – 2472 MHz             | 16 dBm e.i.r.p.                       |
| Näpärmjet kásaj, DENSO TEN Limited deklaron se lloji i aparatit të radios FT0106C është në përputhje me Direktivën 2014/53/EU.<br>Teksti i plotë i deklaratës së BE-së mbi përputhshmërinë është i disponueshëm në adresën e mëposhtme të internetit:<br><a href="https://www.denso-ten.com/support/regulation/eu_doc/">https://www.denso-ten.com/support/regulation/eu_doc/</a> |                             |                                       |
| Funksion   | Banda e frekuencës së punës | Fuqia maksimale e frekuencave radio   |
| Bluetooth  | 2402 - 2480 MHz             | 4 dBm e.i.r.p.                        |
| WLAN   | 2412 – 2472 MHz             | 16 dBm e.i.r.p.                       |
| Ovim, DENSO TEN Limited izjavljuje da je ovaj tip radijske opreme FT0106C u skladu sa odredbama Direktive 2014/53/EU.<br>Kompletan tekst EU deklaracije o konformitetu je dostupan na sledećoj internet adresi:<br><a href="https://www.denso-ten.com/support/regulation/eu_doc/">https://www.denso-ten.com/support/regulation/eu_doc/</a>                                       |                             |                                       |
| Funkcija   | Radni frekvenčni pojas      | Maksimalna radiofrekvenčna snaga      |
| Bluetooth  | 2402 - 2480 MHz             | 4 dBm e.i.r.p.                        |
| WLAN   | 2412 – 2472 MHz             | 16 dBm e.i.r.p.                       |
| Härmed försäkrar DENSO TEN Limited att denna typ av radioutrustning FT0106C överensstämmer med direktiv 2014/53/EU.<br>Den fullständiga texten till EU-försäkran om överensstämmelse finns på följande webbadress:<br><a href="https://www.denso-ten.com/support/regulation/eu_doc/">https://www.denso-ten.com/support/regulation/eu_doc/</a>                                    |                             |                                       |
| Funktion   | Operationsfrekvensbandet    | Maximal radiofrekvenseffekt           |
| Bluetooth  | 2402 - 2480 MHz             | 4 dBm e.i.r.p.                        |
| WLAN   | 2412 – 2472 MHz             | 16 dBm e.i.r.p.                       |
| DENSO TEN Limited, FT0106C türü telsiz ekipmanının 2014/53/EU Direktifine uygun olduğunu beyan etmektedir.<br>AB uygunluk beyanının tam metnine aşağıdaki internet adresinden ulaşılabilir:<br><a href="https://www.denso-ten.com/support/regulation/eu_doc/">https://www.denso-ten.com/support/regulation/eu_doc/</a>   |                             |                                       |
| İşlev  | Çalışma frekans bandı       | Maksimum radyo-frekans gücü           |
| Bluetooth  | 2402 - 2480 MHz             | 4 dBm e.i.r.p.                        |
| WLAN   | 2412 – 2472 MHz             | 16 dBm e.i.r.p.                       |
| справжнім DENSO TEN Limited заявляє, що тип радіобладнання відповідає Технічному регламенту радіобладнання;<br><br>моделі: FT0106B, FT0106C<br><br>повний текст декларації про відповідність доступний на веб-сайті за такою адресою:<br><a href="https://www.denso-ten.com/support/regulation/ua_doc/">https://www.denso-ten.com/support/regulation/ua_doc/</a>                 |                             |                                       |
| типу радіобладнання  | смузі радіочастот           | максимальну потужність випромінювання |
| Bluetooth  | 2402 - 2480 MHz             | 4 dBm e.i.r.p.                        |
| WLAN   | 2412 - 2472 MHz             | 16 dBm e.i.r.p.                       |
| Підприємство з іноземними інвестиціями «Тойота-Україна»<br><br>Україна, Київ, проспект Степана Бандери, 24-Б   |                             |                                       |

**Declaration of Conformity (DoC)**

Hereby, Harman Becker Automotive Systems GmbH declares that the radio equipment type HM Extension Unit is in compliance with Directive 2014/53/EU. The full text of the EU declaration of conformity is available at the following internet address: (\*1)

Harman Becker Automotive Systems GmbH vakuuttaa, että radiolaitetyyppi HM Extension Unit on direktiivin 2014/53/EU mukainen. EU-vaatimustenmukaisuusvakuutuksen täysimittainen teksti on saatavilla seuraavassa internetosoitteessa: (\*1)

Hierbij verklaar ik, Harman Becker Automotive Systems GmbH, dat het type radioapparatuur HM Extension Unit conform is met Richtlijn 2014/53/EU. De volledige tekst van de EU-conformiteitsverklaring kan worden geraadpleegd op het volgende internetadres: (\*1)

Le soussigné, Harman Becker Automotive Systems GmbH, déclare que l'équipement radioélectrique du type HM Extension Unit est conforme à la directive 2014/53/UE. Le texte complet de la déclaration UE de conformité est disponible à l'adresse internet suivante: (\*1)

Härmed försäkrar Harman Becker Automotive Systems GmbH att denna typ av radioutrustning HM Extension Unit överensstämmer med direktiv 2014/53/EU. Den fullständiga texten till EU-försäkran om överensstämmelse finns på följande webbadress: (\*1)

Hermed erklærer Harman Becker Automotive Systems GmbH, at radioudstyrstypen HM Extension Unit er i overensstemmelse med direktiv 2014/53/EU. EU-overensstemmelseserklæringens fulde tekst kan findes på følgende internetadresse: (\*1)

Hiermit erklärt Harman Becker Automotive Systems GmbH, dass der Funkanlagentyp HM Extension Unit der Richtlinie 2014/53/EU entspricht. Der vollständige Text der EU-Konformitätserklärung ist unter der folgenden Internetadresse verfügbar: (\*1)

Με την παρούσα ο/η Harman Becker Automotive Systems GmbH, δηλώνει ό τι ο ραδιοεξοπλισμός HM Extension Unit πληροί την οδηγία 2014/53/ΕΕ. Το πλήρες κείμενο της δήλωσης συμμόρφωσης ΕΕ διατίθεται στην ακόλουθη ιστοσελίδα στο διαδίκτυο: (\*1)

Il fabbricante, Harman Becker Automotive Systems GmbH, dichiara che il tipo di apparecchiatura radio HM Extension Unit è conforme alla direttiva 2014/53/UE.

Il testo completo della dichiarazione di conformità UE è disponibile al seguente indirizzo Internet: (\*1)

Por la presente, Harman Becker Automotive Systems GmbH declara que el tipo de equipo radioeléctrico HM Extension Unit es conforme con la Directiva 2014/53/UE.

El texto completo de la declaración UE de conformidad está disponible en la dirección Internet siguiente: (\*1)

O(a) abaixo assinado(a) Harman Becker Automotive Systems GmbH declara que o presente tipo de equipamento de rádio HM Extension Unit está em conformidade com a Diretiva 2014/53/UE.

O texto integral da declaração de conformidade está disponível no seguinte endereço de Internet: (\*1)

B'dan, Harman Becker Automotive Systems GmbH, niddikjara li dan it-tip ta' tagħmir tar-radju HM Extension Unit huwa konformi mad-Direttiva 2014/53/UE.

It-test kollu tad-dikjarazzjoni ta' konformità tal-UE huwa disponibbli f'dan l-indirizz tal-Internet li ġej: (\*1)

Käesolevaga deklareerib Harman Becker Automotive Systems GmbH, et käesolev raadioseadme tüüp HM Extension Unit vastab direktiivi 2014/53/EL nõuetele. ELi vastavusdeklaratsiooni täielik tekst on kättesaadav järgmisel internetiaadressil: (\*1)

Harman Becker Automotive Systems GmbH igazolja, hogy a HM Extension Unit típusú rádióberendezés megfelel a 2014/53/EU irányelvnek. Az EU-megfelelőségi nyilatkozat teljes szövege elérhető a következő internetes címen: (\*1)

Harman Becker Automotive Systems GmbH týmto vyhlasuje, že rádiové zariadenie typu HM Extension Unit je v súlade so smernicou 2014/53/EÚ. Úplné EÚ vyhlásenie o zhode je k dispozícii na tejto internetovej adrese: (\*1)

Tímto Harman Becker Automotive Systems GmbH prohlašuje, že typ rádiového zařízení HM Extension Unit je v souladu se směrnicí 2014/53/EU. Úplné znění EU prohlášení o shodě je k dispozici na této internetové adrese: (\*1)

Harman Becker Automotive Systems GmbH potrjuje, da je tip radijske opreme HM Extension Unit skladen z Direktivo 2014/53/EU. Celotno besedilo izjave EU o skladnosti je na voljo na naslednjem spletnem naslovu: (\*1)

Aš, Harman Becker Automotive Systems GmbH, patvirtinu, kad radijo į renginių tipas HM Extension Unit atitinka Direktyvą 2014/53/ES. Visas ES atitikties deklaracijos tekstas prieinamas šiuo interneto adresu: (\*1)

Ar šo Harman Becker Automotive Systems GmbH deklarē, ka radioiekārta HM Extension Unit atbilst Direktīvai 2014/53/ES. Pilns ES atbilstības deklarācijas teksts ir pieejams šādā interneta vietnē: (\*1)

Harman Becker Automotive Systems GmbH niniejszym oświadcza, że typ urządzenia radiowego HM Extension Unit jest zgodny z dyrektywą 2014/53/UE. Pełny tekst deklaracji zgodności UE jest dostępny pod następującym adresem internetowym: (\*1)

Hér, Harman Becker Automotive Systems GmbH lýsir yfir að radióbúnaður tegund HM Extension Unit er í samræmi við tilskipun 2014/53 / EB. The fullur texti af ESB-samræmisýfirlýsing er í boði á eftirfarandi veffangi: (\*1)

Herved Harman Becker Automotive Systems GmbH erklærer at radioutstyr type HM Extension Unit er i samsvar med direktiv 2014/53 / EU. Den fullstendige teksten i EU-erklæring er tilgængelig på følgende internetadresse : (\*1)

С настоящото Harman Becker Automotive Systems GmbH декларира, че този тип радиосъоръжение HM Extension Unit е в съответствие с Директива 2014/53/ЕС. Цялостният текст на ЕС декларацията за съответствие може да се намери на следния интернет адрес: (\*1)

Harman Becker Automotive Systems GmbH ovime izjavljuje da je radijska oprema tipa HM Extension Unit u skladu s Direktivom 2014/53/EU. Cjeloviti tekst EU izjave o sukladnosti dostupan je na sljedećoj internetskoj adresi: (\*1)

Цяма компанія Harman Becker Automotive Systems GmbH заявляє, що радіообладнання, тип HM Extension Unit (модуль розширення Harman), відповідає положенням Директиви 2014/53/EU. Повний текст Декларації про відповідність директивам ЄС міститься за таким посиланням: (\*1)

GPS frequency : 1575,42 MHz +/- 2 MHz (Receiving only)

(\*1) <http://www.harman.com/compliance>

Harman Becker Automotive Systems GmbH  
Infotainment Marketing  
Becker-Goering-Str.16  
D-76307 Karlsbad Germany

#### **TARGET MARKET: UKRAINE**



справжнім (Harman Becker Automotive Systems GmbH) заявляє, що тип радіообладнання (HM Extension Unit) відповідає Технічному регламенту радіообладнання;  
повний текст декларації про відповідність доступний на веб-сайті за такою адресою: <http://www.harman.com/compliance>

Використовуваний частотний спектр  
GPS: 1575,42 MHz +/- 2 MHz (Тільки для отримання)

Підприємство з іноземними інвестиціями «Тойота-Україна»  
ПІІ «Тойота-Україна»  
Україна, Київ, проспект Степана Бандери, 24-Б

Gracenote, the Gracenote logo and logotype, “Powered by Gracenote”, MusicID, Playlist Plus and Media VOCS are either registered trademarks or trademarks of Gracenote, Inc. in the United States and/or other countries.



#### **Gracenote® End User License Agreement - Music**

This application or device contains software from Gracenote, Inc. of Emeryville, California (“Gracenote”). The software from Gracenote (the “Gracenote Software”) enables this application to perform disc and/or file identification and obtain music-related information, including name, artist, track, and title information (“Gracenote Data”) from online servers or embedded databases (collectively, “Gracenote Servers”) and to perform other functions. You may use Gracenote Data only by means of the intended End-User functions of this application or device.

This application or device may contain content belonging to Gracenote's providers. If so, all of the restrictions set forth herein with respect to Gracenote Data shall also apply to such content and such content providers shall be entitled to all of the benefits and protections set forth herein that are available to Gracenote.

You agree that you will use Gracenote Data, the Gracenote Software, and Gracenote Servers for your own personal non-commercial use only. You agree not to assign, copy, transfer or transmit the Gracenote Software or any Gracenote Data to any third party. **YOU AGREE NOT TO USE OR EXPLOIT GRACENOTE DATA, THE GRACENOTE SOFTWARE, OR GRACENOTE SERVERS, EXCEPT AS EXPRESSLY PERMITTED HEREIN.**

You agree that your non-exclusive license to use the Gracenote Data, the Gracenote Software, and Gracenote Servers will terminate if you violate these restrictions. If your license terminates, you agree to cease any and all use of the Gracenote Data, the Gracenote Software, and Gracenote Servers. Gracenote reserves all rights in Gracenote Data, the Gracenote Software, and the Gracenote Servers, including all ownership rights. Under no circumstances will Gracenote become liable for any payment to you for any information that you provide. You agree that Gracenote, Inc. may enforce its rights under this Agreement against you directly in its own name.

The Gracenote service uses a unique identifier to track queries for statistical purposes. The purpose of a randomly assigned numeric identifier is to allow the Gracenote service to count queries without knowing anything about who you are. For more information, see the web page for the Gracenote Privacy Policy for the Gracenote service.

The Gracenote Software and each item of Gracenote Data are licensed to you “AS IS.” Gracenote makes no representations or warranties, express or implied, regarding the accuracy of any Gracenote Data from in the Gracenote Servers. Gracenote reserves the right to delete data from the Gracenote Servers or to change data categories for any cause that Gracenote deems sufficient. No warranty is made that the Gracenote Software or Gracenote Servers are error-free or that functioning of Gracenote Software or Gracenote Servers will be uninterrupted. Gracenote is not obligated to provide you with new enhanced or additional data types or categories that Gracenote may provide in the future and is free to discontinue its services at any time.

GRACENOTE DISCLAIMS ALL WARRANTIES EXPRESS OR IMPLIED, INCLUDING, BUT NOT LIMITED TO, IMPLIED WARRANTIES OF MERCHANTABILITY, FITNESS FOR A PARTICULAR PURPOSE, TITLE, AND NON-INFRINGEMENT. GRACENOTE DOES NOT WARRANT THE RESULTS THAT WILL BE OBTAINED BY YOUR USE OF THE GRACENOTE SOFTWARE OR ANY GRACENOTE SERVER. IN NO CASE WILL GRACENOTE BE LIABLE FOR ANY CONSEQUENTIAL OR INCIDENTAL DAMAGES OR FOR ANY LOST PROFITS OR LOST REVENUES.

copyright © 2000 to present Gracenote